

GLENDINNING

CABLEMASTER

Shore Power Cable Storage System

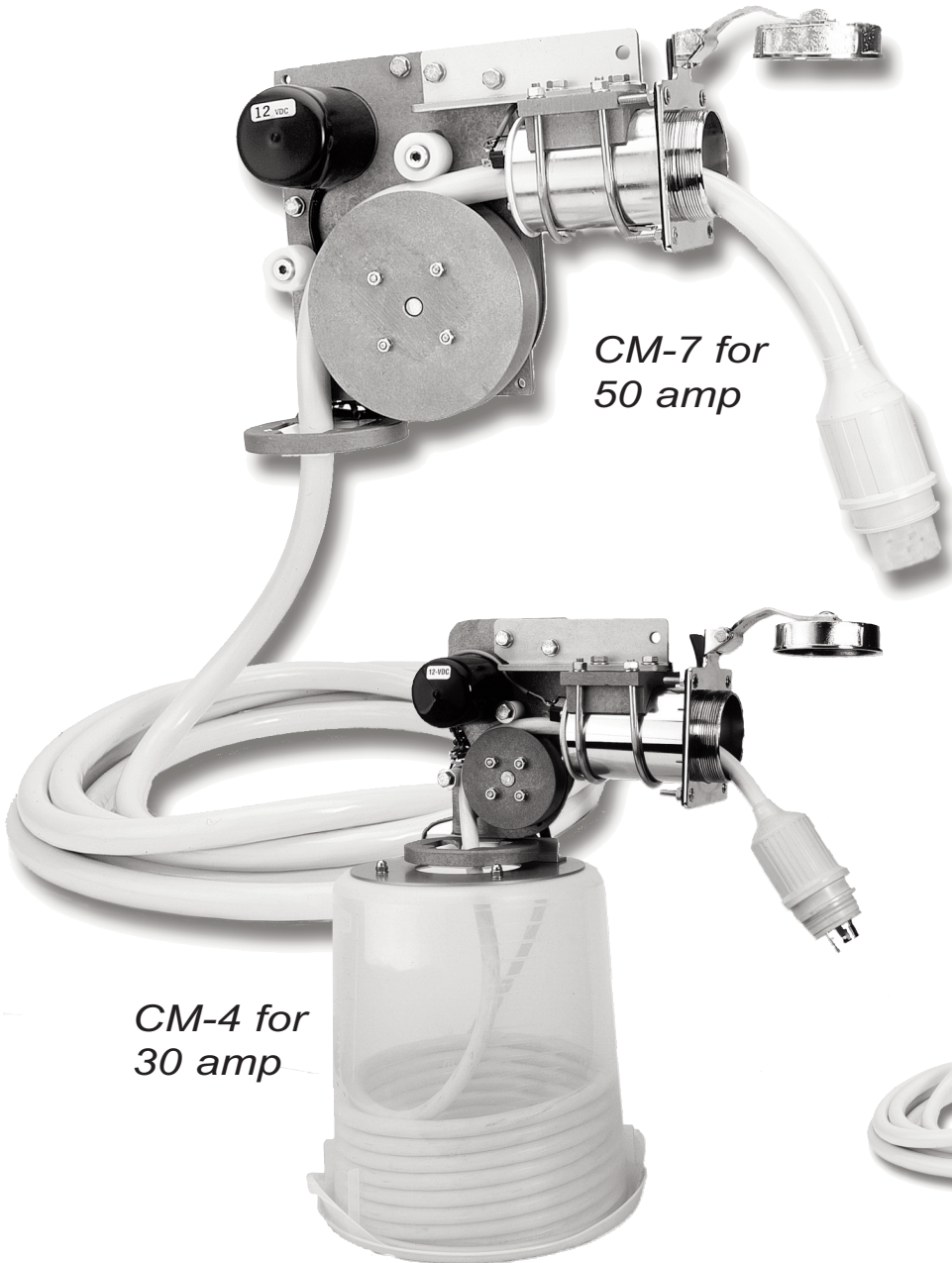

*CM-7 for
50 amp*

*CM-4 for
30 amp*

GUIDE TO:

- **DESCRIPTION**
- **INSTALLATION**
- **OPERATION**

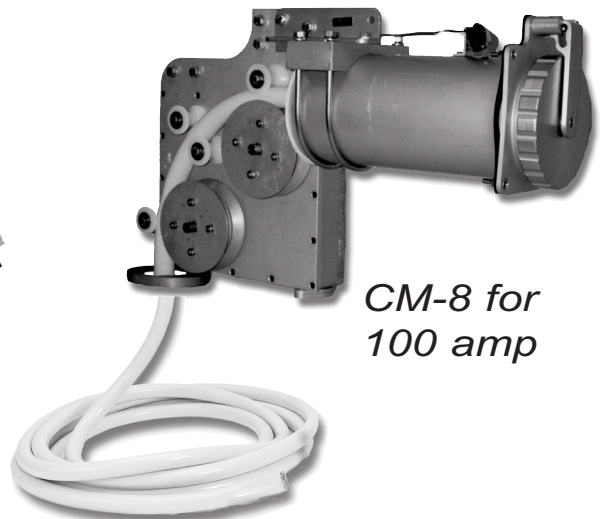

*CM-8 for
100 amp*



**740 Century Circle
Conway, SC 29526**

**Phone: (843) 399-6146
Fax: (843) 399-5005
www.glendinningprods.com**

TABLE OF CONTENTS

THANK YOU...	PAGE 1
INTRODUCTION	PAGE 1
GETTING TO KNOW YOUR CABLEMASTER	PAGE 2
INSTALLATION OVERVIEW	PAGE 3
Location for Power Unit & Cable	PAGE 3
Hawse Pipe & Cable Plug Exit	PAGE 3
Connection to Electrical System	PAGE 3
TYPES OF INSTALLATIONS	PAGE 4
INSTALLATION INSTRUCTIONS	PAGE 5
WIRING INSTRUCTIONS	PAGE 6
POWER CABLE INSTALLATION	PAGE 8
CABLE ADJUSTMENT	PAGE 8
AC WIRING INSTRUCTIONS	PAGE 9
MAINTENANCE	PAGE 9
OPERATION OF CABLEMASTER	PAGE 10
TROUBLESHOOTING GUIDE	PAGE 10
CABLEMASTER DIMENSIONS	PAGE 11
CABLEMASTER WIRING DIAGRAM	PAGE 15
CABLEMASTER ACCESSORIES	PAGE 17

THANK YOU...

for buying the Glendinning Cablemaster. At Glendinning, we are committed to providing you, our customer, with a product that will yield trouble-free service. Care has been taken during each phase of the manufacturing process to guarantee a lifetime of quality and performance—after all, our name is on it!



Paul & John Glendinning

INTRODUCTION

Welcome to the Glendinning family of quality marine products. Your new *Cablemaster* carries the same assurance of quality that has stood behind every product from Glendinning Marine Products for over 30 years—we're proud of our reputation for quality products and service.

While installation on most boats is straight forward and easy, for those perplexing situations, nothing beats a qualified marine electrician. Using common sense about safety and a sound mechanical approach during the installation, the *Cablemaster* will provide many hours of trouble-free service.

All *Cablemasters* have been designed to pay out and retract shore power cables without overloading the motor within the system's power unit. Properly adjusted, a *Cablemaster* will drag 75 feet (maximum) of shore power cable without slippage.

The *Cablemaster* consists of two major components; the **hawse pipe** and **power unit**. The chromed hawse pipe is designed to accommodate varying sizes of shore power cables with the attached 30 or 50amp shore power plug cover. Within the hawse pipe, a neoprene gasket/wiper prevents the entrance of water and helps clean the cable as it is retracted into the boat. When the cable is retracted completely, the plug cover actuates the in-limit switch which is mounted on the face of the gasket plate inside the hawse pipe.

The drive motor, reduction gearing, guide roller assembly and the relay assembly comprise the power unit. The power unit is connected to the hawse pipe with a hawse pipe clamp and a length of extruded aluminum angle. The hawse pipe clamp allows the power unit to be angled to either side of vertical directing the shore power cable toward the storage compartment. The main pulley of the *Cablemaster* is also freewheeling which allows the cable to be manually payed in or out.

The out-limit switch is located in the guide roller assembly. The nylon safety collar, which is installed around the shore power cable, activates the out-limit switch. This collar also serves as a mechanical stopping device should the limit switch fail or should the shore power cable be forcibly pulled outward.

ATTENTION!

In preparing this manual, Glendinning Marine Products, Inc. has relied upon the standards established by the National Electric Code and the recommended practices and standards for AC electrical systems for vessels prepared by the American Boat and Yacht Council, Inc. This manual reflects practices and standards in effect at the time of publication and is intended only as a guide to understand the *Cablemaster*. Glendinning Marine Products, Inc. will not be liable for any loss, damage, incidental or consequential damages of any kind, arising in connection with the use or reliance upon this manual.

GETTING TO KNOW YOUR CABLEMASTER

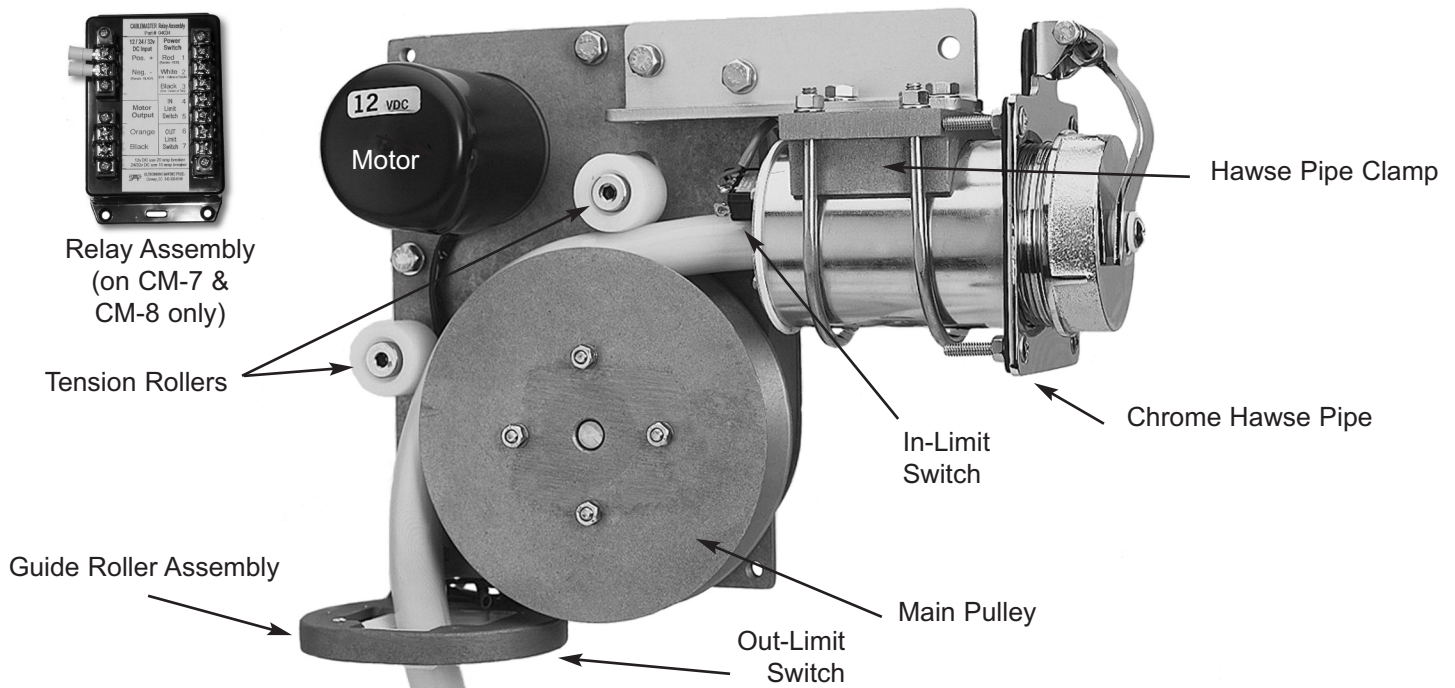

3 MODELS TO CHOOSE FROM:

All *Cablemasters* are designed to eliminate the physically demanding task of paying out and coiling up your shore power cable. Powered extension and retraction is available at the flip of a switch! There are 3 models to choose from:

- 1) **CM-4 Cablemaster** — the CM-4 was designed to handle 30 amp shore power cable. The CM-4 usually comes attached to it's own storage container to make installation as easy as possible. You may also order the CM-4 with TV / telephone cable installed instead of 30 amp shore power cable.
- 2) **CM-7 Cablemaster** — the CM-7 (the workhorse of the *Cablemaster* line) was designed to handle 50 amp shore power cable.
- 3) **CM-8 Cablemaster** — the CM-8 is our "heavy duty" version of the CM-7. The CM-8 will handle 100 amp shore power cable. You definitely don't want to be extending and retracting this heavy cable by hand!

All of these units can be configured to your boat's specifications by utilizing the many accessories which aid in installation and operation of the *Cablemaster*.

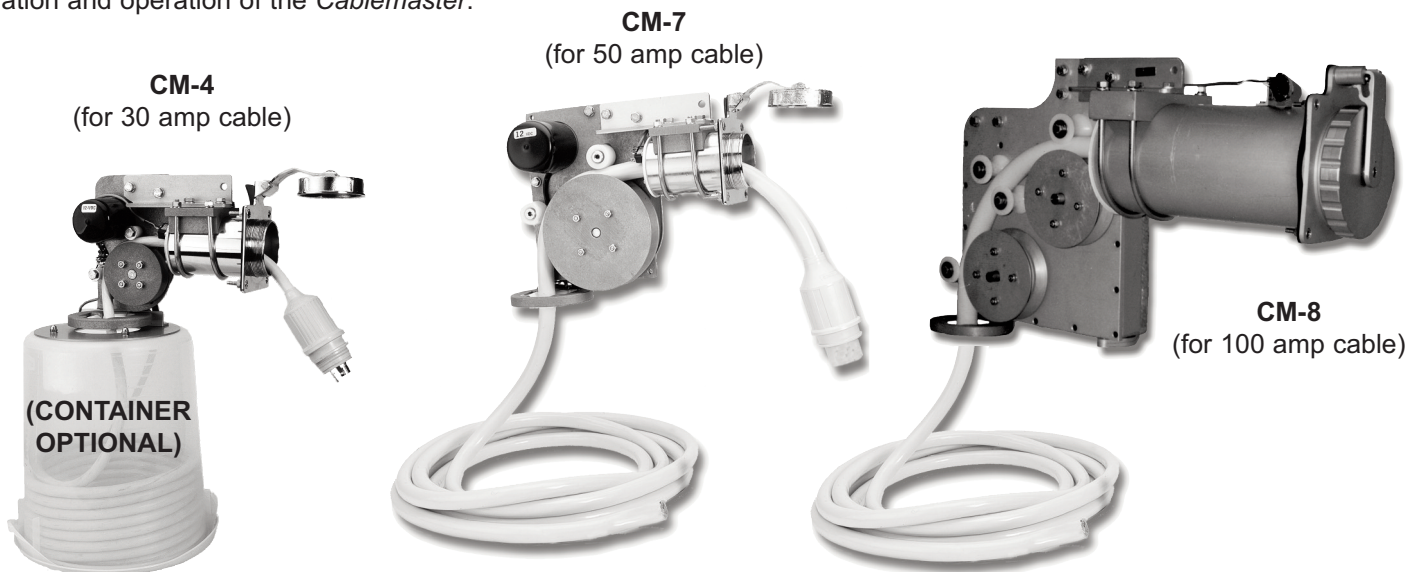



INSTALLATION OVERVIEW

BEFORE installing your *Cablemaster*, consider the following three points:

1 LOCATION FOR POWER UNIT & CABLE :

Perhaps the prime consideration in determining the best location for mounting your *Glendinning Cablemaster* is to remember that the key to a good installation is allowing enough room for the shore power cable to coil without restriction. The power unit should be mounted *directly over the storage container*, but may be offset a maximum of 20 degrees where space deems it to be necessary. Here are a few pointers to keep in mind when looking at your boat.

MINIMUM CABLE STORAGE AREA:

- A. **30 amp cable** — 14" x 14" (see Fig. 1)
 1. For 50 feet of 30 amp 10/3, a minimum of 15" is required from guide roller assembly to the bottom of container.
- B. **50 amp cable** — 18" x 18" (see Fig. 1)
 1. For 75 feet of 50 amp 6/4, a minimum of 23" is required from the guide roller assembly to the bottom of the storage container. 18" is required from the guide roller assembly to the bottom of the storage container if a 15" x 22" diameter container is used.

SUITABLE STORAGE CONTAINERS:

- A. Heavy duty garbage barrel
- B. Round baitwell
- C. Any enclosed area free of tubing, wiring or structural projections allowing the cable to free-fall may be used. (Glueing strips of *formica* to 1" x 2" or 2" x 2" may be suitable in applications where the storage area is close to the rough inside surface of a fiberglass hull)
- D. *Molded styrene containers* (18" - 22" in diameter and in varying heights) are available from Glendinning Marine Products, Inc. (see accessory page)

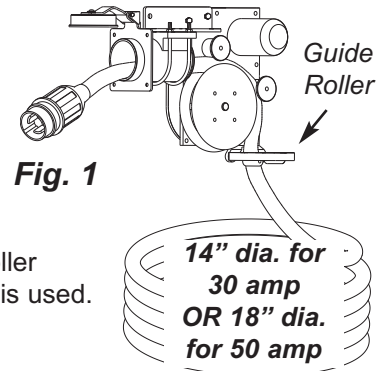
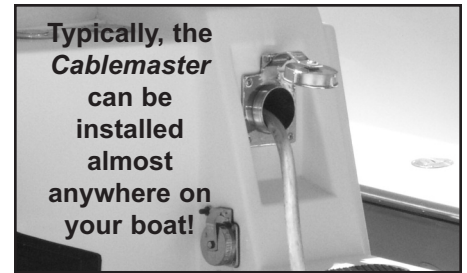

2 HAWSE PIPE & POWER CORD PLUG EXIT :

Also be careful to remember that the selection of the hawse pipe location is in a large measure determined by the proper location of the power unit and cable storage area. Be sure that the hawse pipe's location is practical for common dockage situations. Avoid a location where the shore power cable could present an obstacle on decks or passageways when in use.

3 CONNECTION TO THE BOAT ELECTRICAL SYSTEM :

Prior to the installation of the *Cablemaster*, consider how the unit is connected to the boat's electrical system (see drawing right). The blunt cut end of the power cable should exit the bottom of the cable storage area. This end can be connected to the Power Transfer Switch which *automatically* switches power for your boat's electrical system between the on-board generator and the shore power cable hook-up, or connected to a junction box.

The *Cablemaster* is now "hard-wired" to your boat's electrical system. It is no longer necessary to use the power cord connection that was part of your yacht's power system.

The power cable must be connected to the boat AC electrical system in accordance with the instructions contained in the National Electrical Code. Care should be taken when installing the white stop collar to ensure that no strain will be placed upon the power cable connection to the electrical system. (NOTE: Leave 1/2 coil in storage container when stop collar activates out limit switch.)

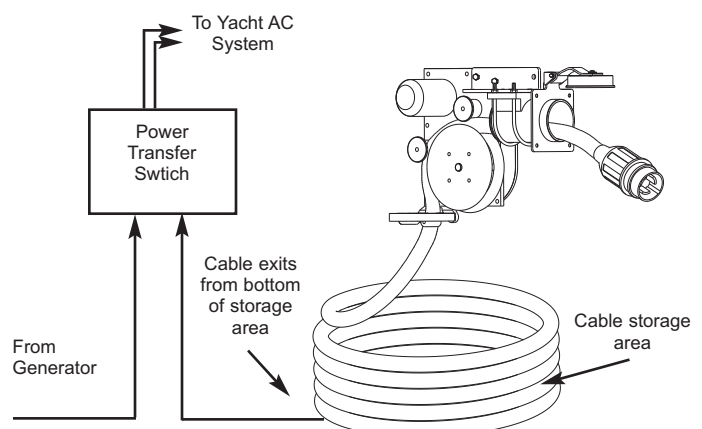



TYPES OF INSTALLATIONS

STANDARD (CLOSE COUPLED) INSTALLATION

The *Cablemaster* works best when the power unit is mounted directly above the storage container. This will ensure proper cable extension and retraction and is recommended providing storage space is available where hawse pipe is to be mounted (Fig. 2).

HORIZONTAL EXTENSION

When storage space is not available directly under the power unit, the power unit can be moved away from the hawse pipe. The standard and shortest length of the connection between the power unit and the hawse pipe is 6 5/8". This connection may be extended up to 16" through the use of the optional long angle link (CM accessory). The power unit can also be remote mounted up to 12* away from the hawse pipe using the optional horizontal pipe extension and a length of 3" schedule 40 PVC pipe (Fig. 3). In both of these configurations, the power unit will require additional mounting support. An overhead mounting bracket is available which allows the power unit to be remote mounted to the overhead.

VERTICAL EXTENSION

Schedule 40 3" dia PVC pipe is also recommended when the shore cable is being directed vertically through the deck. In this installation it is necessary to use the optional vertical pipe extension (see accessory page) and to remove the guide roller assembly from the power unit and relocate it to the bottom of the pipe extension. Since this contains the out-limit switch, it is also necessary to reconnect the out-limit switch by extending the wire to the relay box (Fig. 4).

OTHER INSTALLATION OPTIONS

Any number of mounting arrangements can be accomplished using the PVC pipe to remote mount the power unit or guide the shore power cable below deck. The mounting possibilities are further enhanced by the fact that the shore power cable can be directed to the right or left of vertical by adjusting the U-clamps on the hawse pipe (Fig. 5).

NOTE: A pipe to pipe angle assembly is available where a straight pipe cannot be used between the hawse pipe and power unit. This angle connector may be used in the horizontal or vertical pipe and is equipped with rollers to provide minimal cable friction. It will work satisfactorily up to 30 degrees (see accessory page).*

NOTE: The side angle adjustment should not exceed 45 degrees and the use of standard PVC elbows is not recommended as they tend to restrict the movement of the cable within the pipe.

Selection of the hawse pipe location is in a large measure determined by the proper location of the power unit and cable storage area. Be sure that the hawse pipe's location is practical for common dockage situations. Avoid a location where the shore power cable could present an obstacle on decks or passageways when in use. An optional recessed mounting bezel is available which allows the hawse pipe to be flush mounted (see accessory page). Shown at right (Fig. 6 & 7) are other installation possibilities for mounting the power unit and directing the cable to the storage area.

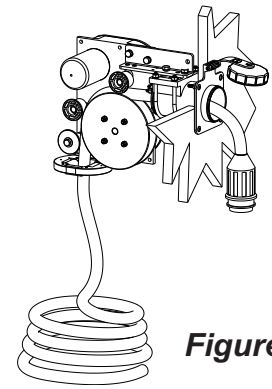

Figure 2

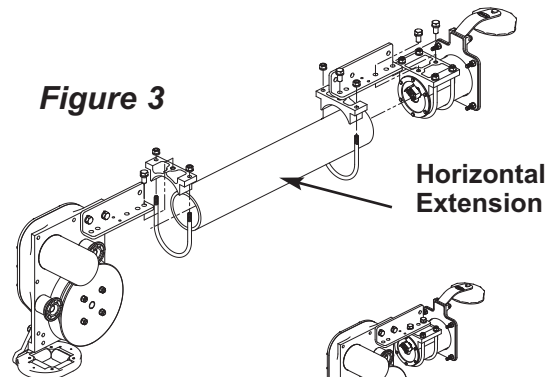
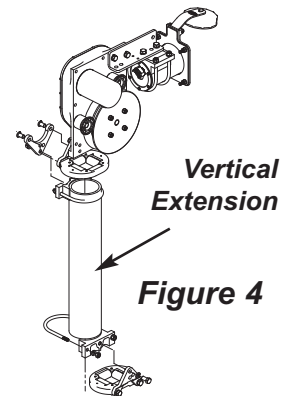

Figure 3

Horizontal Extension



Vertical Extension

Figure 4

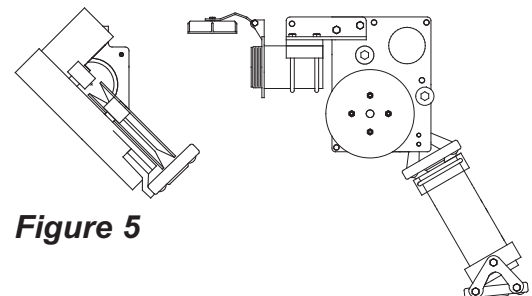

Figure 5

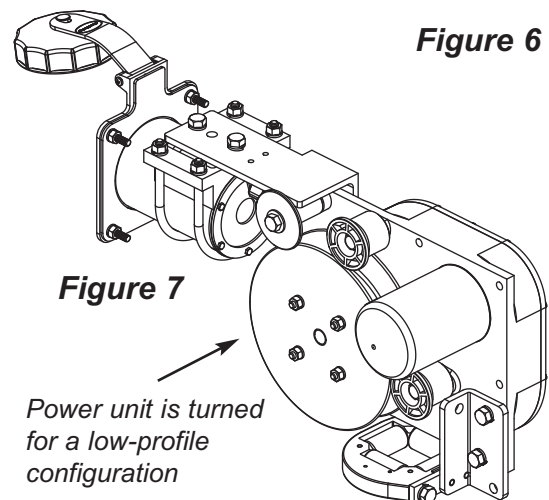

Figure 6

Figure 7

Power unit is turned for a low-profile configuration



INSTALLATION INSTRUCTIONS

The *Cablemaster* system must be mounted in a location that is protected from the marine environment and is certified "ignition protected" for placement in engine rooms. For ideas on specific locations for your boat, contact our service engineer.

STEP 1: MARK MOUNTING LOCATION FOR HAWSE PIPE

Using the drawing included with your manual, mark the mounting location of the hawse pipe. Before drilling or cutting, check once again to be certain that the area behind the hawse pipe is free of wires, plumbing or structural supports for the boat. The mounting surface should be a minimum 1/2" thick. The proper thickness can be achieved by using a butt block of marine grade plywood behind the mounting surface.

STEP 2: CUT CENTER HOLE & MOUNT HAWSE PIPE

Cut the hawse pipe's 3-5/8" center hole and drill the four 1/4" mounting holes. Using a good quality marine beading compound, secure the hawse pipe to the boat using the four (4) 1/4 x 20 x 1" stainless steel machine screws, washers, nuts and gasket supplied with the *Cablemaster* or use longer fasteners that are available locally.

STEP 3: MOUNT POWER UNIT TO HAWSE PIPE

The power unit may now be mounted to the hawse pipe using the angle link, the hawse pipe clamp, and U-bolts. In remote power unit installations, the 3" schedule 40 PVC pipe is secured to the power unit using the same standard components adding also the accessories for horizontal pipe extension in order to connect the PVC pipe to the hawse pipe (see Fig. 3 previous page).

STEP 4: WIRE CABLEMASTER TO ELECTRICAL SYSTEM

Unless the shore power cable is being directed vertically through a PVC pipe, you are now ready to wire the *Cablemaster* to the boat's DC electrical system. If the shore power cable is being directed vertically through PVC pipe (see drawing below) it is necessary to relocate the guide roller assembly with the out-limit switch from the bottom of the power unit to the lower end of the PVC pipe. Wires of appropriate length will have to be spliced into the system to insure the operation of the out-limit switch. A guide roller assembly without the out-limit switch, included in the vertical pipe extension accessory, must be installed between the power unit and the PVC pipe to provide trouble free operation (see accessory page).

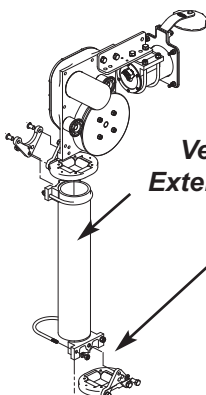

Vertical Extension

Relocate guide roller assembly with out-limit switch to end of PVC pipe extension

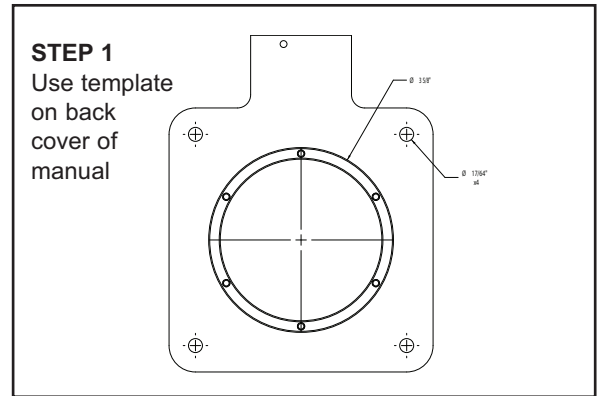

STEP 1
Use template on back cover of manual

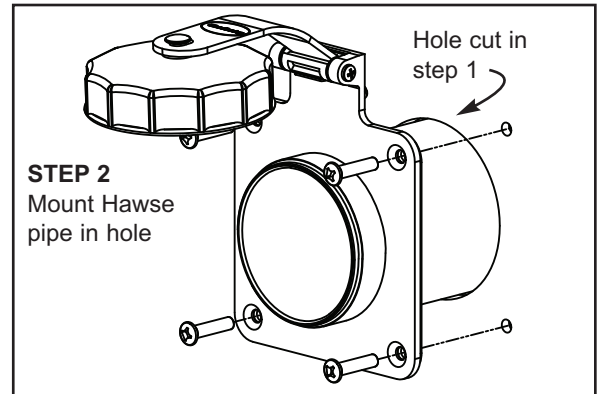

STEP 2
Mount Hawse pipe in hole

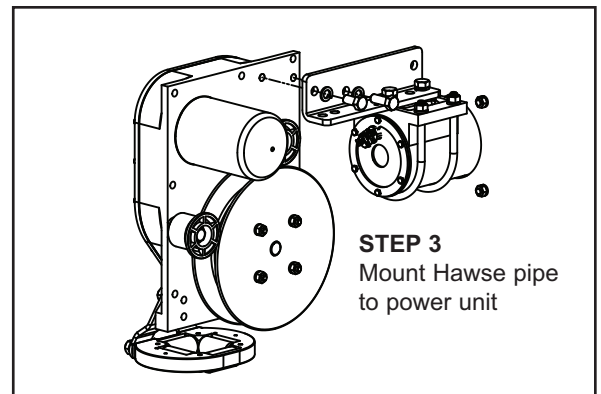

STEP 3
Mount Hawse pipe to power unit

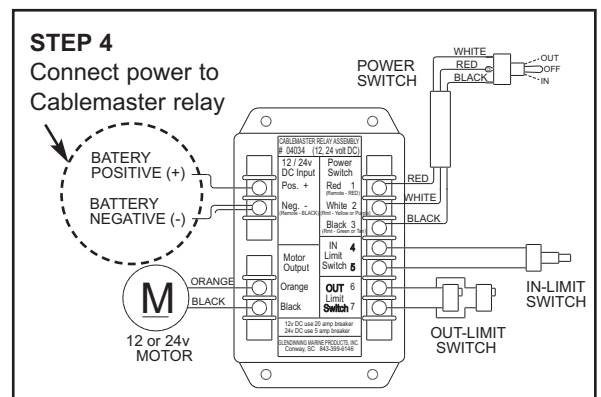

STEP 4
Connect power to Cablemaster relay



CABLEMASTER WIRING INSTRUCTIONS *(see wiring diagram, page 15)*

Some wiring instructions are basic to the wiring of the *Cablemaster* regardless what model (CM-4, CM-7 or CM-8) you purchased.

FIRST, all wiring should be done in accordance with the instructions contained in the National Electrical Code. If there is any uncertainty as to the proper methods of wiring, a qualified and competent electrician should do the wiring.

SECOND, overcurrent protection (fuse or circuit breaker) must be provided in the power supply to the *Cablemaster*. On 12v DC systems, a 20 amp fuse or circuit breaker should be used; on 24v DC systems, a 15 amp fuse or circuit breaker is required. In addition to providing electrical "overload" protection, a separate breaker for the *Cablemaster* allows the unit to be turned "off" thus preventing the unauthorized use of the unit when left unattended. *This is especially IMPORTANT if the switch is located where it can easily be actuated by children.*

Follow the instructions below for the specific model you purchased:

WIRING THE CM-4 CABLEMASTER

THE CM-4 POWER UNIT is wired through a barrier strip.

All electrical connections to the barrier strip have been completed at the factory to make for easy installation. All that is required by the installer is to attach the battery to the appropriate terminals on the barrier strip.

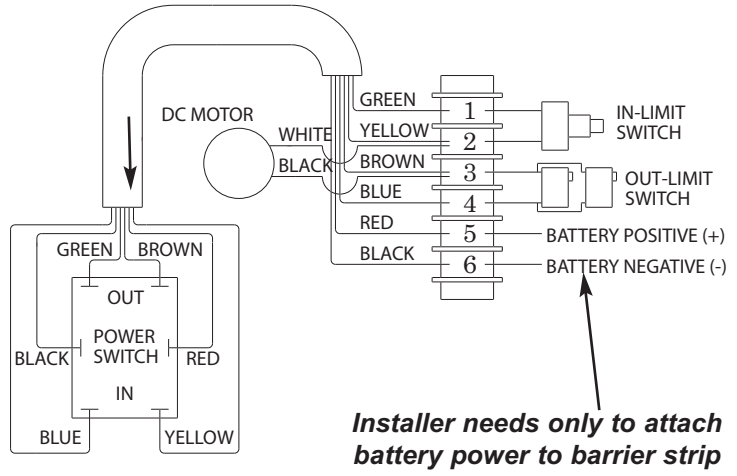

Installer needs only to attach battery power to barrier strip

TYPICAL CM-4 BARRIER STRIP WIRING

Using 12 gauge, stranded wire, the positive DC power supply is connected to the #5 terminal on the barrier strip and the negative to the #6 terminal (see drawing right). Be sure to observe proper polarity when connecting the DC input wires.

Both the limit switches are designed to automatically stop the motor when the cable has reached its' limit of travel. The in-limit switch is located in the hawse pipe gasket ring and is covered by a neoprene cover to shield it from moisture. The in-limit switch, which is connected to the #1 and #2 terminals on the barrier strip, is activated when the plug cover touches the switch.

The out-limit switch, which is connected to the #3 and #4 terminals of the barrier strip, is located in the guide roller assembly mounted on the lower side of the power unit and is activated by a nylon safety collar secured near the terminal end of the shore power cable. The collar, which acts as a positive mechanical "stop" as well as a means to activate the out-limit switches, should be fitted around the shore power cable at a point that allows adequate slack in the cable for unstrained AC electrical connections. If the shore power cable is being directed through the vertical pipe extension, it is necessary to relocate the guide roller assembly with the out-limit switch from the power unit to the lower end of the vertical pipe and to reconnect the out-limit switch using the appropriate lengths of wire.

(NOTE: Failure to install the nylon safety collar and rewire the out-limit switch can result in damage to the shore power cable's electrical connection.)

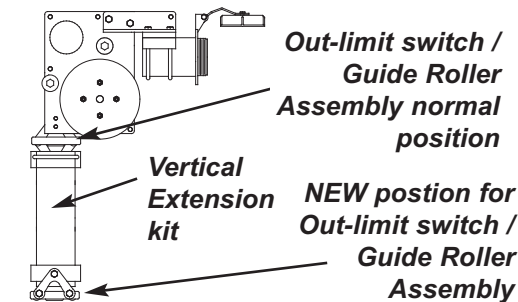

The six conductor cable for the power switch is numerically marked to correspond with the numbers on the barrier strip. For convenience and ease of operation, the power switch should be mounted near the hawse pipe or in the appropriate hole with the optional bezel. In each case, the power switch must be protected by the neoprene cover to prevent the intrusion of moisture.



CABLEMASTER WIRING INSTRUCTIONS (CON'T.)

WIRING THE CM-7 OR CM-8 CABLEMASTER

THE **CM-7 AND CM-8 POWER UNITS** are wired through an integral relay assembly for 12 or 24 volt DC depending on your boat's voltage. The voltage for each *Cablemaster* is located on the unit's label. The *Cablemaster* should be connected to a separate circuit breaker of appropriate amperage (see Fig. 9) on the main or auxiliary DC electrical distribution panel. In addition to providing electrical "overload" protection, a separate breaker for the *Cablemaster* allows the unit to be turned "OFF" thus preventing the unauthorized use of the unit when the boat is unattended. This is especially important if the switch is located where it can easily be actuated by children on board.

Be sure to observe the proper polarity when connecting the DC input wires.

Both the limit switches are designed to automatically stop the motor when the cable has reached it's limit of travel. The in-limit switch is located in the hawse pipe gasket ring and is covered by a neoprene cover to shield it from moisture. The in-limit switch, which is connected to the #4 and #5 terminals on the relay assembly, is activated when the plug cover touches the switch.

The out-limit switch, which is connected to the #6 and #7 terminals of the relay assembly, is located in the guide roller assembly mounted on the lower side of the power unit and is activated by a nylon safety collar secured near the terminal end of the shore power cable. The collar, which acts as a positive mechanical "stop" as well as a means to activate the out-limit switches, would be fitted around the shore power cable at a point that allows adequate slack in the cable for unstrained AC electrical connections (The same collar is used for 6/3 or 6/4 cable). If the shore power cable is being directed through the vertical pipe extension, it is necessary to relocate the guide roller assembly with the out-limit switch from the power unit to the lower end of the vertical pipe and to reconnect the out-limit switch using the appropriate lengths of wire (NOTE: Failure to install the nylon safety collar and rewire the out-limit switch can result in damage to the shore power cable's electrical connection).

The 3 conductor cable for the power switch is color coded to correspond with the terminal strip on the relay assembly. For convenience and ease of operation, the power switch should be mounted near the hawse pipe or in the appropriate hole with the optional bezel (see accessories). In each case, the power switch must be protected by the neoprene cover to prevent the intrusion of moisture.

The relay box is mounted on a sub-plate and may be attached to the power unit cover screws in two ways (see label on sub-plate). This provides easy access in making wiring connections. If desirable, it may also be mounted on a bulkhead close by to the power unit making sure that the connecting wires are fastened away from the pulley and rollers.

TYPICAL CM-7 / CM-8 RELAY ASSEMBLY WIRING

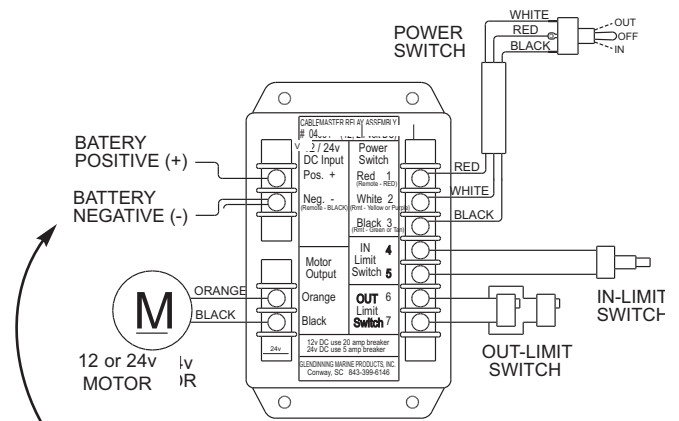

Installer needs only to attach battery power to relay assembly

NOTE 1

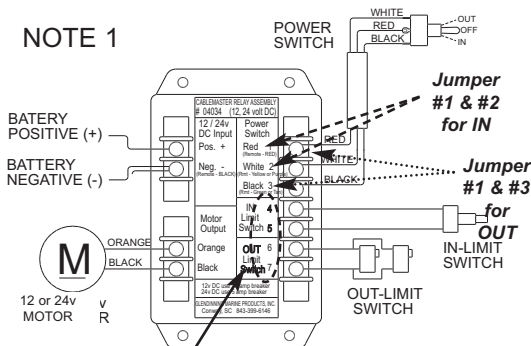

Jumper wires must be attached to #4 & #5, and #6 & #7 if IN Limit and OUT Limit Switches are not connected

NOTE 1: On installation of the CM-7 or CM-8 Cablemaster, convenient temporary operation or remote control of the Cablemaster by the installer may be desirable. With the power switch, limit switches and battery connected, first jumper #1 and #2 to retract cable, then jumper #1 and #3 to extend cable. This enables the installer to directly supervise the coiling of the cable at the storage area. Remove when Cablemaster installation is complete.

NOTE 2: Do not attach voltage wires to the motor wires while they are still fastened to the barrier strip. This will cause a short in the relay assembly. Remove the motor wires from the barrier strip then connect battery power to the motor wires for check-out of motor operation.



POWER CABLE INSTALLATION

Before installing the power cable into the *Cablemaster*, stretch the cable out in a straight line on a smooth surface to remove any kinks or unnatural coils. Feed the “blunt cut” end of the cable into the power unit. Retract the power cable, using the power switch or manually. Before connecting the power cable to boat’s AC electrical system, secure the nylon safety collar and refer to the Cable Adjustment section below to pre-adjust the pulley to the proper cable size and to insure trouble-free operation of your *Cablemaster*. The power cable should be firmly strapped down, using metal or heavy duty plastic wiring straps, to the bottom of the cable storage area so that in no way will the *Cablemaster* pull on the power cable’s electrical connection.

In actual usage of your *Cablemaster*, you will find that the power cable is seldom payed out completely. Because of this, it is advisable to occasionally pay out the cable completely and allow the cable to recoil into its natural coil.

The power cable must be connected to your boat’s AC electrical system in accordance with the instructions contained in the National Electrical Code. Care should be taken when adjusting the out-limit collar to ensure that no strain will be placed upon the power cable connection to the electrical system.



CABLE ADJUSTMENT

Shore power cable diameters vary from one cable manufacturer to another, the *Cablemaster’s* main pulley is split in half and proper friction adjustment between the cable and main pulley is necessary at the time of installation. Too tight adjustment will overload the motor. On the other hand, too loose an adjustment will result in slippage of the cable or no movement of the cable.

The *Cablemaster* should be able to pay in and out the cable without any slippage or any undue strain depending on the installation, and distance from the Hawse Pipe to the *Cablemaster*. Some assistance will be required when extending power cord on long extension runs or multiple bend installations. Retracting the power cord should not be any problem.

To adjust the friction between the main pulley and the power cable follow the instructions below:

- 1) Remove the 1/4” nuts and lockwashers from the face of the main pulley and remove the outer pulley half.
- 2) Remove or add* only equal amounts of spacers for each bolt.
- 3) Replace the pulley half and secure the nuts.

**When adjusting pulley friction, only add (decreases tension) or remove (increases tension) one (1) spacer from each bolt before checking the unit for the correct pulley friction. One spacer makes a substantial difference in cable tension.*

SIDE VIEW

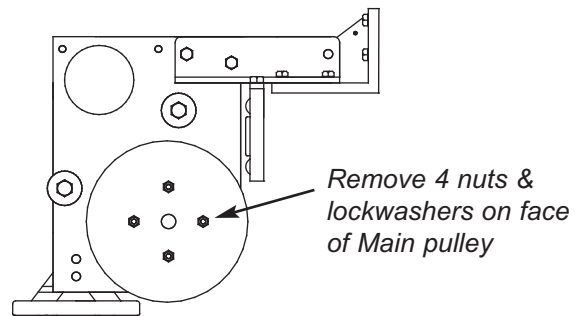

REAR VIEW

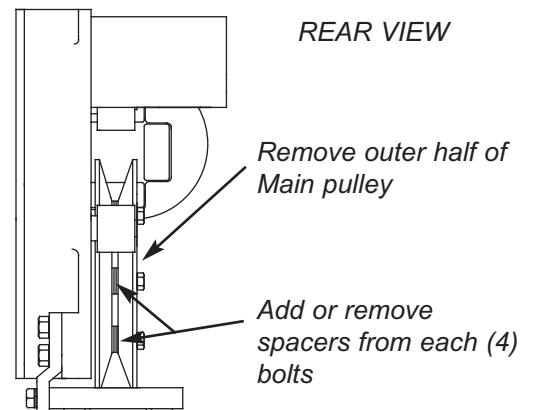



AC WIRING INSTRUCTIONS

WARNING: It is extremely important that the wiring of the power cord to your boat's electrical system be done properly. If there is any uncertainty as to the proper methods of working with AC wiring, a qualified and competent electrician should do this wiring. Failure to wire correctly may result in DEATH, INJURY, OR DAMAGE TO PERSONS OR VESSEL.

In all electrical applications, minimizing the entrance or accumulation of moisture or water is of prime importance. Junction boxes, receptacles, breakers and other enclosures in which electrical connections are made should be waterproof or be installed in a protected area.

Electricity enters the boat through the power cable. The cable is connected to the Power Transfer Switch which automatically switches power for your boat's electrical system between the on-board generator and the shore power cable hook up. The Power Transfer Switch is then connected to the AC panel board through a main circuit breaker. The power is transferred to the various branch circuits by way of individual branch circuit breakers.

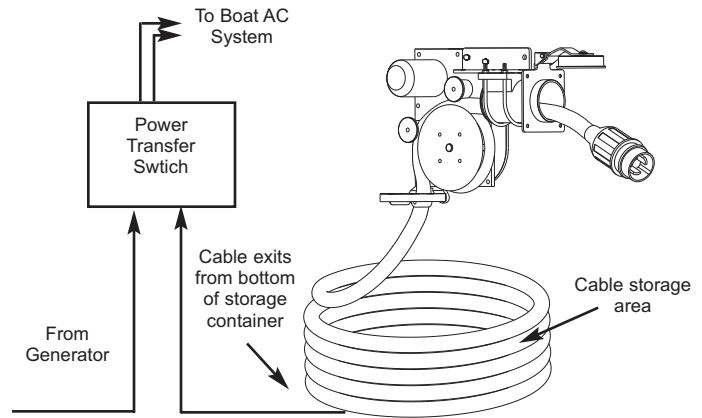

Good practice when installing the *Cablemaster* is to place a waterproof circuit breaker in the system on the boat's exterior in close proximity to the *Cablemaster* hawse pipe. This circuit breaker automatically interrupts the flow of current if the current exceeds the amount the circuit is designed to handle (ie: 30amp or 50amp). This is common practice recommended by ABYC where the distance from the shore power cable inlet is more than 10' away from the AC panelboard.

When two *Cablemaster* units are used on port and starboard installations, the shore power cables must be wired through an approved rotary transfer switch before connection to the main circuit breaker on the AC panelboard. This will provide a safe interlock when switching from one shoreside power source to another.

Remember also that your boat's AC electrical system is "polarized." Polarization of conductors must be observed in the shore cable connections and throughout the entire AC system.



MAINTENANCE

Experience has shown that when only a short section of the power cable is regularly used, the cable may be subject to sharper than normal coiling which in turn causes undue "kinking" of the cable. To relieve this condition, routinely pay the cable out completely and stretch it on any smooth surface. Allow the *Cablemaster* to then retract the cable into the cable storage area.

At least once a year, check all AC and DC wiring connections to be sure they are secure and free of corrosion. Check the neoprene covers on the in-limit switch and power switch to be sure they are free of cracks or fracture.

Periodically, inspect the exterior jacket of your shore power cable for nicks or cuts. If your shore power cable is dirty DO NOT USE any cleaner that will leave a waxy film on the shore power cable. The waxy film will cause slippage between the *Cablemaster's* main pulley and your shore power cable. It is recommended to use a mild soap and water to clean your cable.



OPERATION OF THE CABLEMASTER

CABLEMASTER OPERATING INSTRUCTIONS FOR CM-4, CM-7, CM-8 MODELS:

TO EXTEND CABLE	TO RETRACT CABLE
<p>1) Flip the power switch to OUT position; grasp the power cord plug.</p> <p>2) Walk to dock power source and plug power cord into receptacle.</p> <p>3) <i>Cablemaster</i> will automatically shut itself OFF when cable has fully extended. If less cable is more desirable, turn switch OFF and place in the IN position.</p> <p>4) Turn power switch OFF when desired cable length is achieved.</p>	<p>1) Disconnect the power cord plug from the dock power source.</p> <p>2) While holding power plug, walk to <i>Cablemaster</i>.</p> <p>3) Flip the power switch to the IN position.</p> <p>4) <i>Cablemaster</i> will automatically shut itself OFF when cable has fully retracted.</p> <p><i>** Do not move vessel until cable is fully retracted!</i></p>



TROUBLE SHOOTING GUIDE

COMPLAINT	PROBABLE CAUSE	RECOMMENDED ACTION
Non-functional (either no power or unit has power and does not respond)	<ul style="list-style-type: none"> • Tripped breaker • Power wire incorrectly connected to relay assembly • Defective motor • Defective relay box 	<ul style="list-style-type: none"> • Reset breaker • Replace relay assembly • With power switch on and voltage across motor wires — if no response, replace motor
Pays out cable only	<ul style="list-style-type: none"> • In-Limit switch circuit open • Power inputs reversed • Defective relay or diode • Bad power switch 	<ul style="list-style-type: none"> • Check in-limit switch • Check polarity on DC input wires • Replace relay assembly • Check power switch
Retracts cable only	<ul style="list-style-type: none"> • Out-Limit switch circuit open • Defective relay • Bad power switch 	<ul style="list-style-type: none"> • Check out-limit switch • Replace relay assembly • Check power switch
Tripped DC breaker	<ul style="list-style-type: none"> • Main pulley too tight • Cable jammed and kinking • Defective motor 	<ul style="list-style-type: none"> • Adjust pulley • Check for adequate storage space and/or cable for undue kinking — see Cable Adjustment (pg. ?) • Disconnect motor wires from relay box. Apply power directly to motor wires; motor should run one direction or other — no response from motor; replace motor



CABLEMASTER DIMENSIONS

CM-7 DIMENSIONS

SPECIFICATIONS

Voltage: 12v DC (24/32v DC available)

Current: 7-9 Amps under load

Weight: 21 lbs. (power unit)

8 lbs. (hawse pipe)

Cable size: 6/4, 50 amp, 220 v

Adjustable (7/8" - 1-1/4" dia.)

Length capacity: Determined by size of storage location

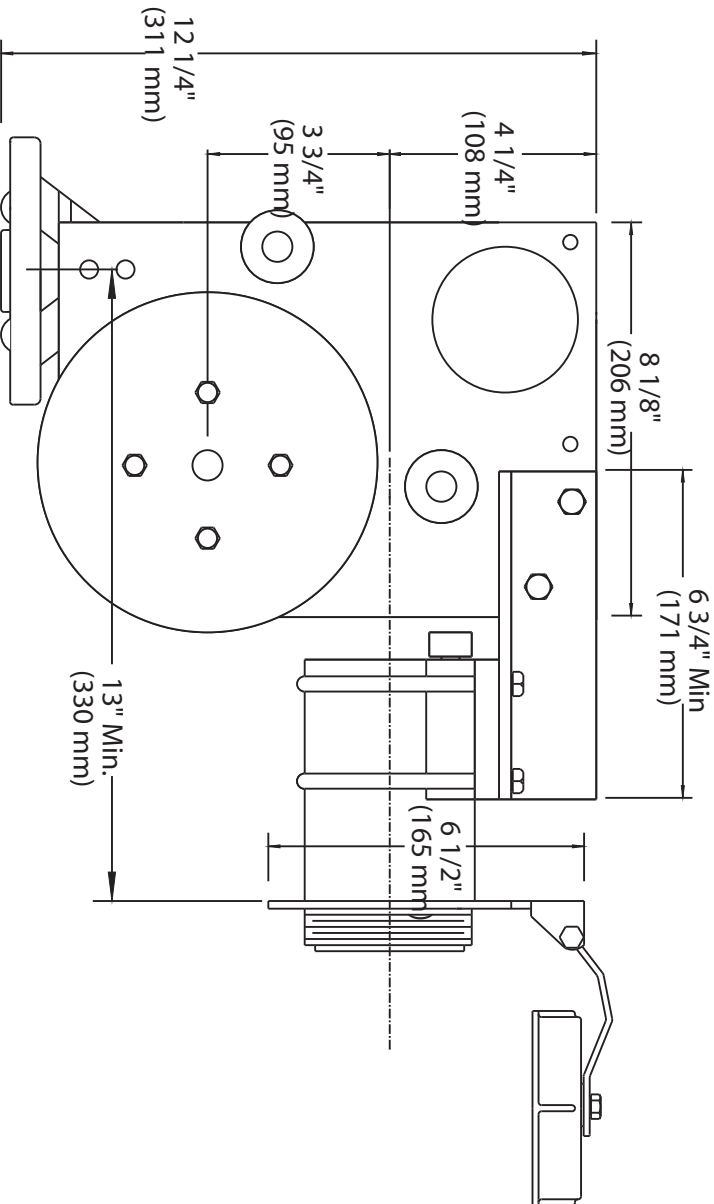
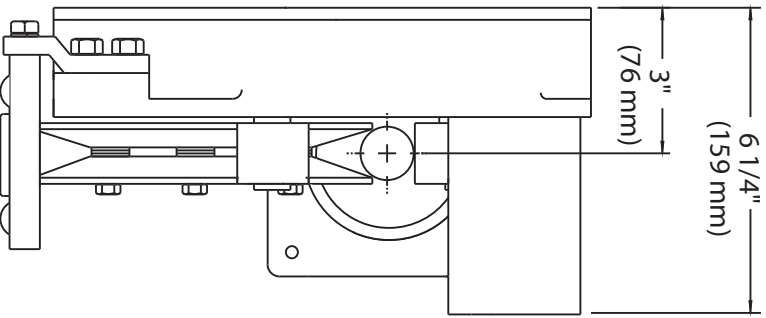
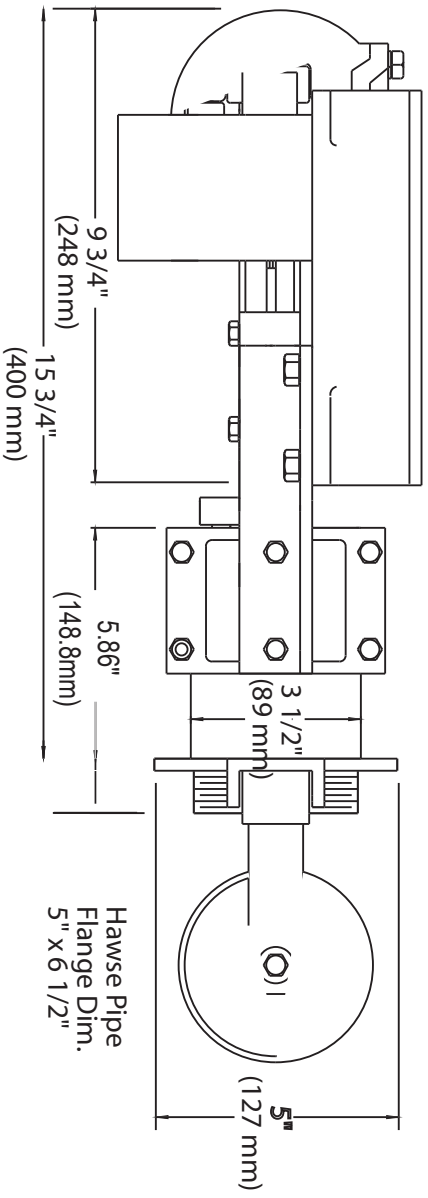

CM-4 DIMENSIONS

Specifications:

- Voltage: 12v DC or 24v DC
- Amperage: 4-5 amps under load
- Dimensions: 5-1/2" L x 6" W x 10" H
(power unit only)
- Weight: 9 lbs.
- Capacity: 30amp 110 volt cable 3/4" diameter
- Length of cable: determined by available storage space

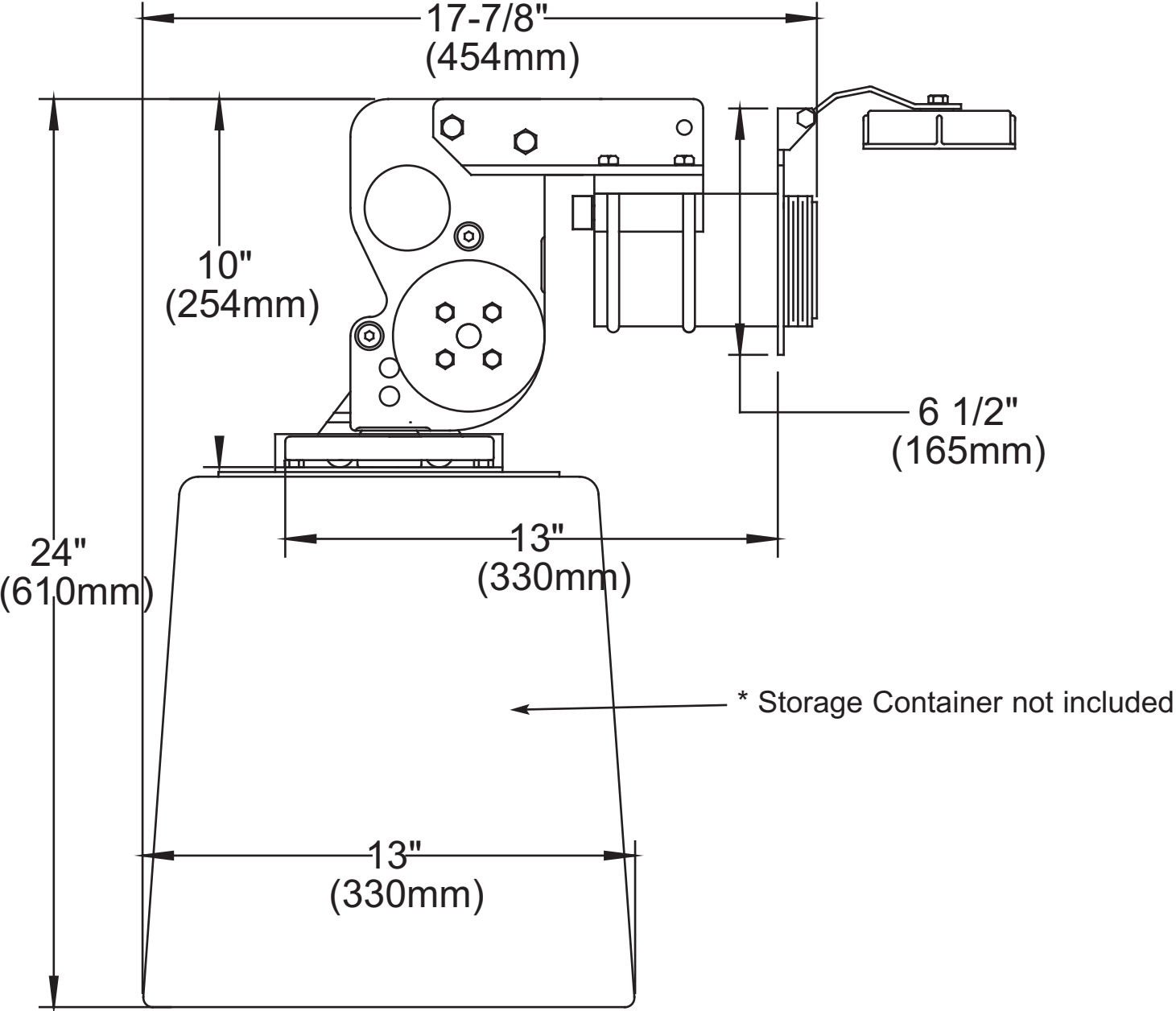

CM-8 DIMENSIONS

SPECIFICATIONS

Voltage: 12V DC (24V DC available).

Current: 7 - 11 Amps under load

Weight: 40 lbs. (Power unit)
12 lbs. (Hawse pipe)

Cable size: up to 2 gauge - 5 conductor, 100amp
Adjustable (1.325" - 1.650" dia.)

Length capacity: Determined by size of storage
location

Material: 6061 Aluminum

Finish: Power Unit: Gold Anodize

Hawse Pipe: Gold or Clear Anodize

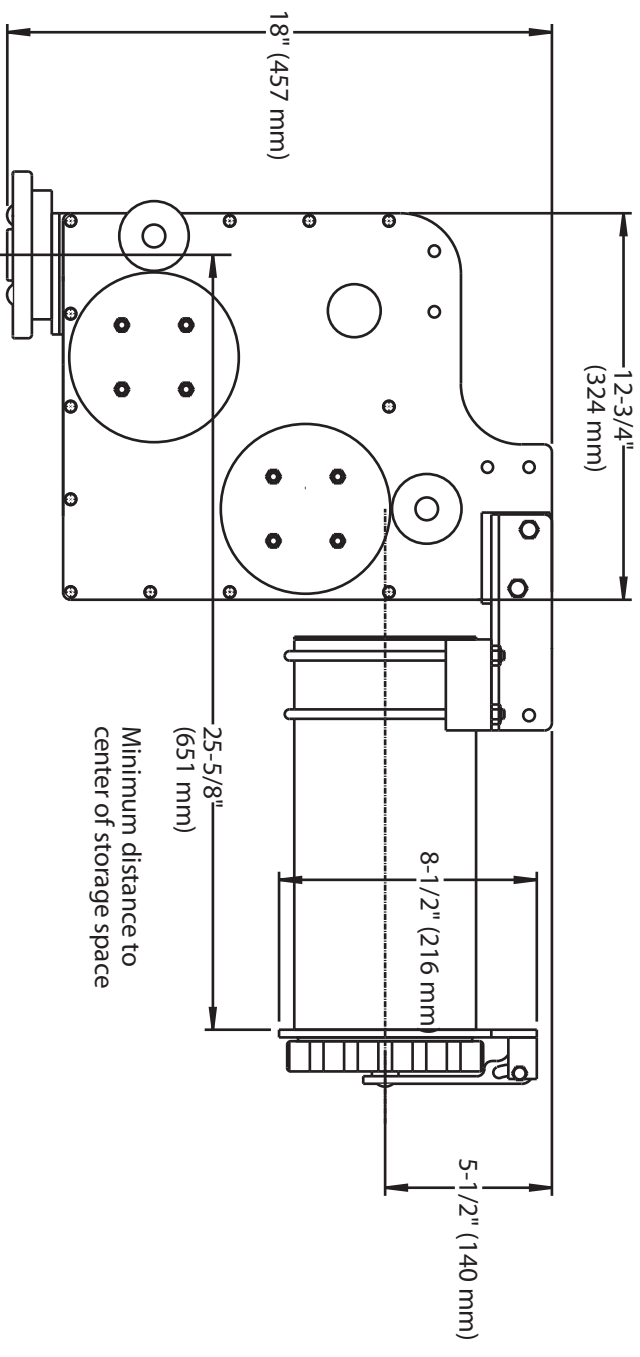
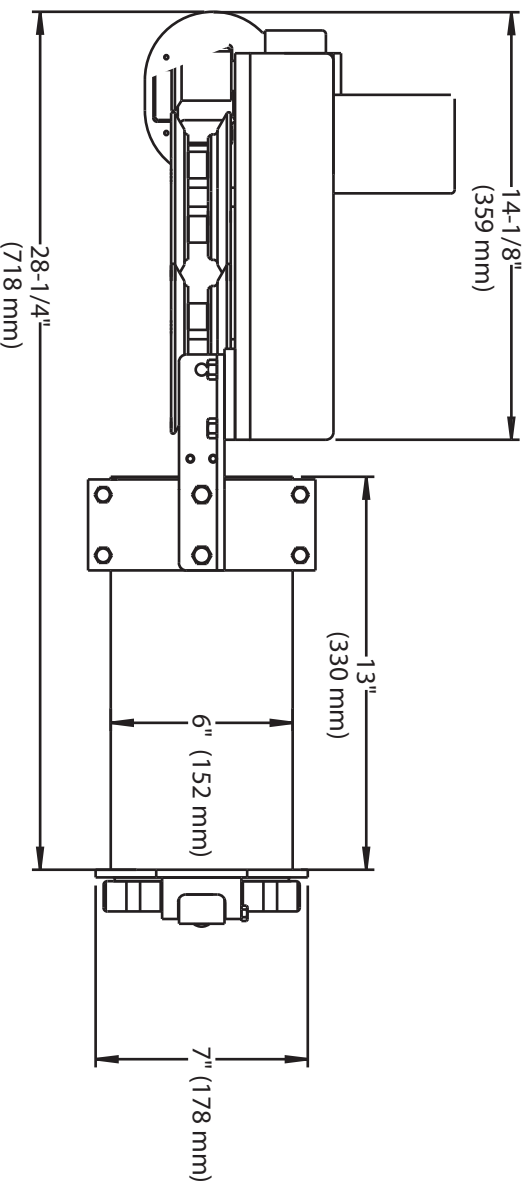
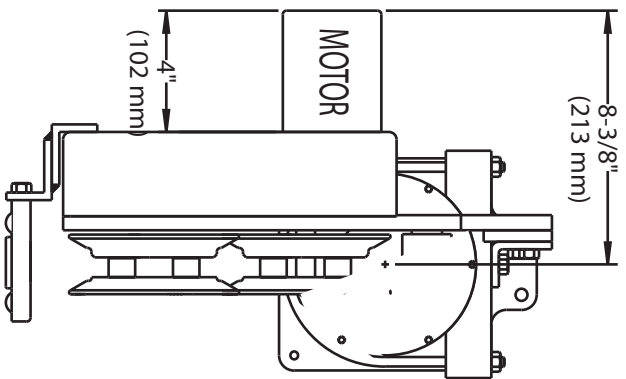

CABLEMASTER MODEL CM-7 PARTS DIAGRAM

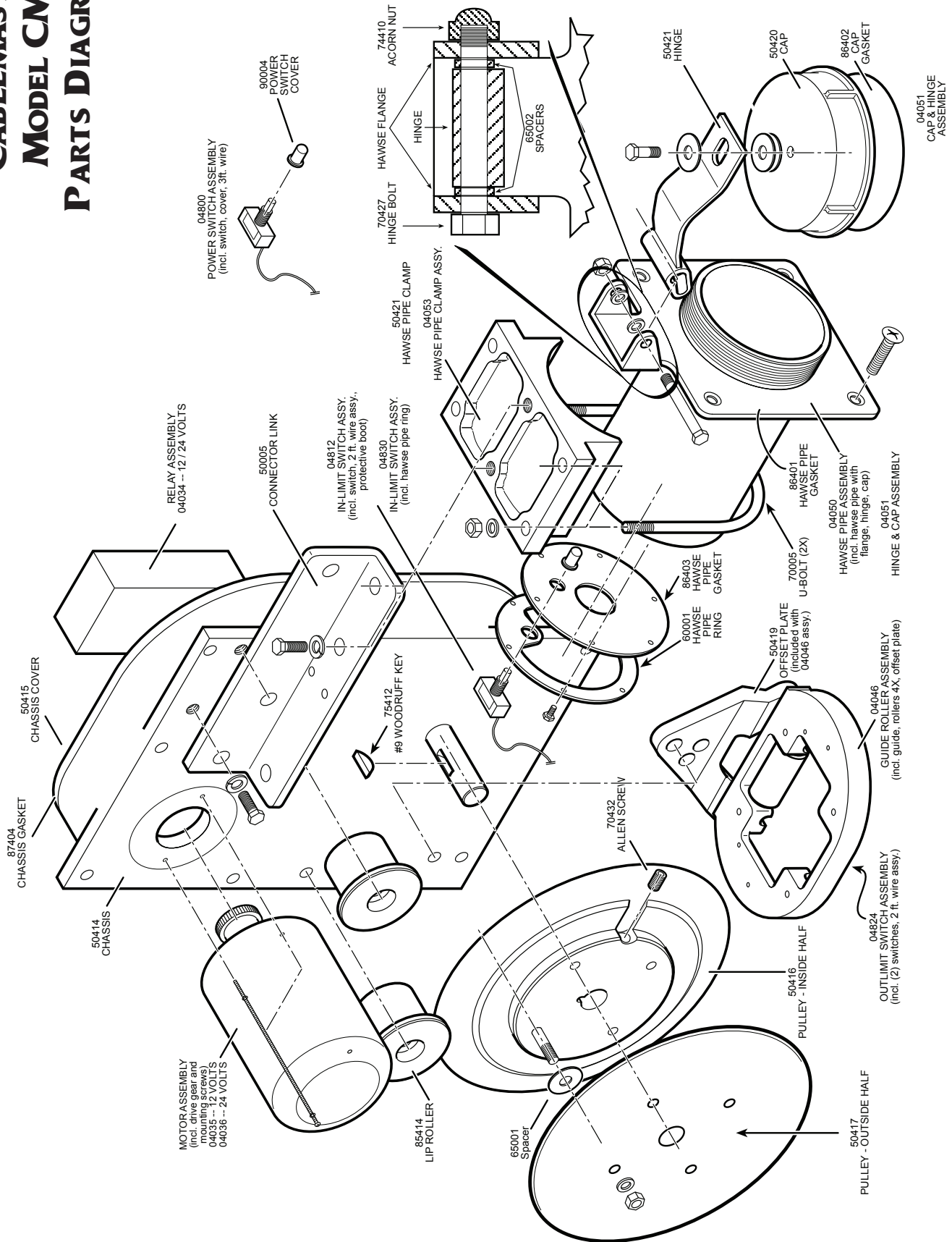



CABLEMASTER WIRING DIAGRAM

CM-7 & CM-8
WIRING DIAGRAM
RELAY ASSEMBLY

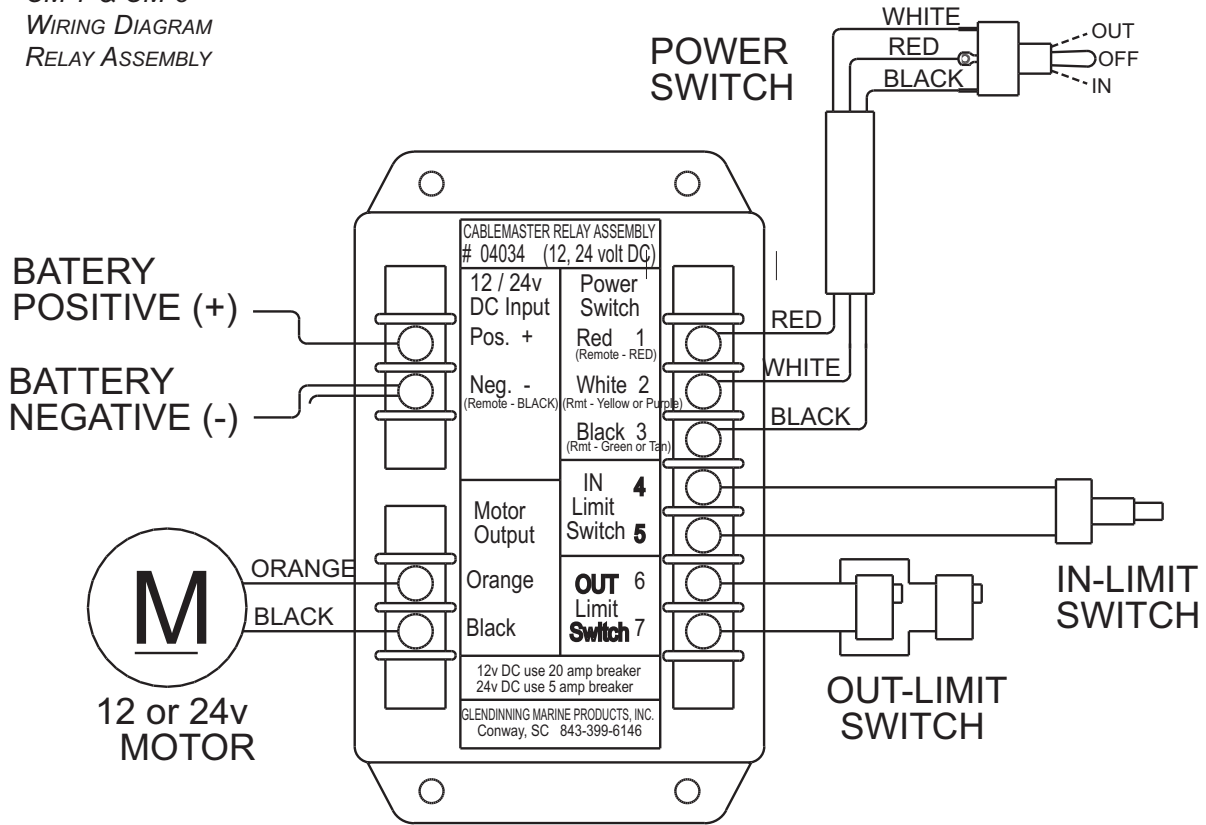

CM-4
WIRING DIAGRAM
BARRIER STRIP ASSEMBLY

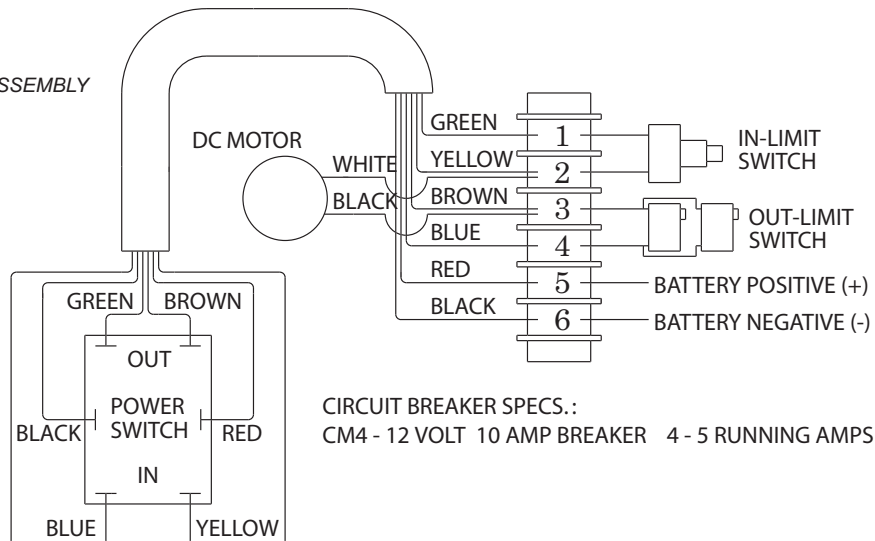

WARRANTY



PRODUCT COVERED BY THIS LIMITED WARRANTY: CABLEMASTER

1. *GLENDINNING MARINE PRODUCTS, INC.* warrants to the original consumer purchaser that the *Cablemaster* will be free from defects in material and workmanship under normal use and service for a period of one (1) year from the date of purchase.
2. *This LIMITED WARRANTY applies to defects in material and workmanship.* It does not apply to chromeplated or anodized finish or to power cable damage caused by inadequate cable storage area or installation not in accordance with *GLENDINNING MARINE PRODUCTS, INC.* specifications.
3. *This LIMITED WARRANTY is void* if the product has been damaged by accident or unreasonable use, neglect, improper installation, or other causes not arising out of defects in material or workmanship.
4. *To obtain performance of this LIMITED WARRANTY* obligation the original purchaser should contact *GLENDINNING MARINE PRODUCTS, INC.* for instructions concerning removal and shipping of the defective component. Upon compliance of the foregoing procedure all warranted defects will be repaired, or at *GLENDINNING MARINE PRODUCTS, INC.* option, the complete unit replaced and returned to the consumer, shipping charges prepaid.
5. *GLENDINNING MARINE PRODUCTS, INC.* does not assume the costs of removal and/or installation of the product or any other incidental costs which may arise as a result of any defect in materials or workmanship.

THIS WARRANTY IS IN LIEU OF ALL OTHER EXPRESS WARRANTIES. ANY WARRANTY IMPLIED BY LAW INCLUDING WARRANTIES OF MERCHANTABILITY OR FITNESS, IS IN EFFECT ONLY FOR THE DURATION OF THE EXPRESS WARRANTIES SET FORTH IN THE FIRST PARAGRAPH ABOVE. NO REPRESENTATIVE OR PERSON IS AUTHORIZED TO GIVE ANY OTHER WARRANTY OR TO ASSUME FOR *GLENDINNING MARINE PRODUCTS, INC.* ANY OTHER LIABILITY IN CONNECTION WITH THE SALE OF IT'S PRODUCTS. *GLENDINNING MARINE PRODUCTS, INC.* WILL NOT BE LIABLE FOR ANY CONSEQUENTIAL DAMAGES RESULTING FROM THE USE OR INSTALLATION OF IT'S PRODUCTS.

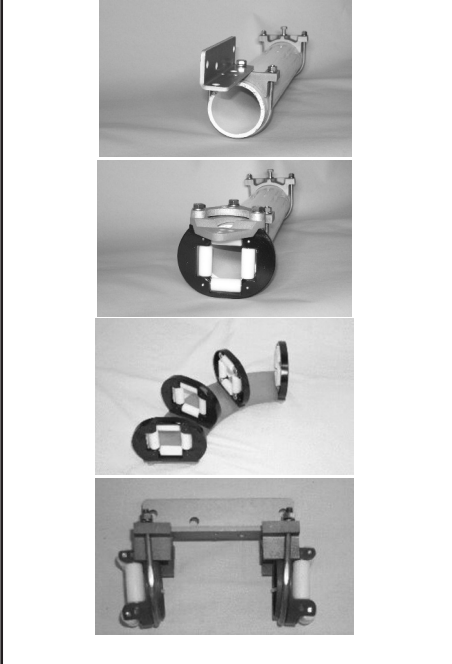

CABLEMASTER ACCESSORIES

PART NUMBER	DESCRIPTION	
94004 94008 94005 94007 94006 99408 99409 99410 99415	<p>SHORE POWER CABLE — <i>power cable sold in bulk.</i></p> <p>6/3 Yellow Jacket Cable — 50 amp 125 volt 6/3 White Jacket Cable — 50 amp 125 volt 6/4 Yellow Jacket Cable — 50 amp 125/250 volt 6/4 White Jacket Cable — 50 amp 125/250 volt 10/3 Yellow Jacket Cable — 30 amp 125 volt</p> <p>SHORE POWER PLUGS AND COVERS — <i>Marinco brand</i></p> <p>50 amp 125/250 volt Shore Power Cable Plug — 6365CR 50 amp 125 volt Shore Power Cable Plug — 6361CR 50 amp Shore Power Cable plug cover — Yellow 50 amp Shore Power Cable plug cover — White</p>	 <p>Stop Collar</p>
04146 04147 04153 04034	<p>RADIO REMOTE CONTROL OPTION — <i>this option allows the remote operation of the Cablemaster unit.</i></p> <p>Radio Remote Control Kit - includes 2 transmitters! Spare / replacement transmitter RF Noise Filter - improves operational range of transmitter Relay Unit - required for addition of Remote on CM-4 models</p>	
85448 85424 85420 85421	<p>POWER CABLE STORAGE CONTAINERS — <i>rotationally molded styrene containers used to store shore power cord.</i></p> <p>16" diameter x 13" height — approx. capacity of 40' of cable 18" diameter x 18" height — approx. capacity of 55' of cable 20" diameter x 18" height — approx. capacity of 75' of cable 22" diameter x 15" height — approx. capacity of 75' of cable</p>	
04043 04044 04062—30° 04064—60° 04066—90° 04063—120° 04067—150° 04065—180° 04045	<p>INSTALLATION ACCESSORIES — <i>these accessories are used to aid in installation of the Cablemaster unit.</i></p> <p>Horizontal Pipe Extension kit — allows Power Unit to be extended away from the Hawse Pipe</p> <p>Vertical Pipe Extension kit — allows the Power Unit to be extended away from the cable storage area</p> <p>Angling Assemblies — used to direct the cable from 30 degree - 180 degree bends (in increments of 30 degrees)</p> <p>Pipe to Pipe Angling Assembly — used with the Vertical Pipe Extension kit for angling the 3" PVC pipe to a desired angle</p>	



HAZARDS STATEMENT

DANGER: ELECTRICAL CORD REELS CAN BE HAZARDOUS. MISUSE CAN RESULT IN FIRE OR DEATH BY ELECTRICAL SHOCK. PLEASE READ CAREFULLY AND FOLLOW INSTRUCTIONS:

- A cord reel marked for indoor use is to be used indoors only.
- Inspect thoroughly before each use. DO NOT USE if damaged.
- Look for the number of watts or amperes on appliances to be plugged into cord reel.
- See label on cord reel for specific watts or amperes.
- DO NOT plug more than the specified number of watts or amperes into this cord reel.
- DO NOT run through doorways, holes in ceilings, walls or floors.
- Make sure appliance is OFF before connecting cord reel to outlet.
- FULLY INSERT plug into outlet.
- DO NOT remove, bend or modify any metal prongs or pins of cord reel.
- DO NOT use excessive force to make connections.
- DO NOT connect a three-prong plug to a two-prong cord reel.
- Keep away from water.
- DO NOT USE WHEN WET.
- Keep children and pets away from cord reel.
- DO NOT plug one cord reel into another.
- AVOID OVERHEATING.
- DO NOT cover with any materials.
- DO NOT drive, drag, or place objects over cord.
- DO NOT walk on cord.
- GRASP PLUG to remove from outlet.
- Always store cord reels INDOORS.
- Always unplug when not in use.
- DO NOT unplug by pulling on cord.

THIS IS A POLARIZED CORD REEL



CABLEMASTER PRODUCT REGISTRATION

Please take a moment to validate your product warranty by mailing in this card with the proper information.

FOLLOW THESE SIMPLE STEPS :

- STEP 1: Fill in the registration card.
- STEP 2: Cut along dotted line.
- STEP 3: Affix correct postage.
- STEP 4: Drop in mailbox.

**OR SEND VIA FAX TO:
(843) 399-5005**



CABLEMASTER WARRANTY REGISTRATION 

NAME _____

ADDRESS _____

CITY _____ STATE _____ ZIP _____

COUNTRY _____ PHONE _____ EMAIL _____

BOAT MODEL & YEAR OF MANUFACTURE _____

CABLEMASTER SERIAL NUMBER _____

WHAT WOULD YOU LIKE TO SEE IMPROVED / CHANGED? _____

WOULD YOU LIKE TO RECEIVE INFO ON NEW PRODUCTS FROM GLENDINNING?
YES NO

THANK YOU!

Hawse Pipe Template

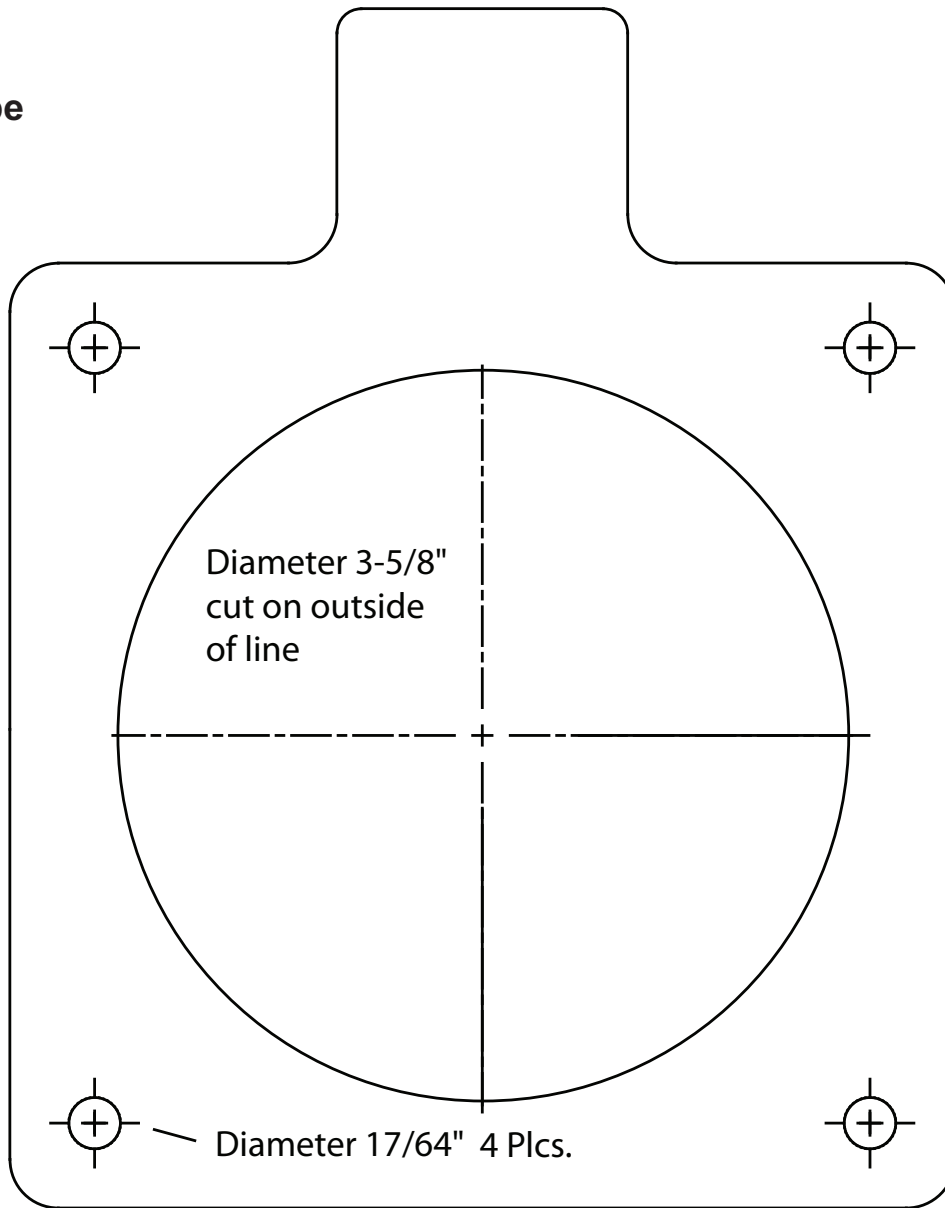

PLACE
STAMP
HERE

PRODUCT WARRANTY INFORMATION



740 CENTURY CIRCLE
CONWAY, SC 29526-8274
USA

SML-CMMAN
PRINT DATE: 06/08