

THE INFORMATION CONTAINED IN THIS DRAWING IS THE SOLE PROPERTY OF Glendinning Marine Products Inc. ANY REPRODUCTION IN PART OR WHOLE WITHOUT THE WRITTEN PERMISSION OF Glendinning Marine Products Inc. IS PROHIBITED.

REV	DESCRIPTION	ECN #	INIT	DATE
A	Redrawn in Solidworks	3009Pn	JT	1/30/06

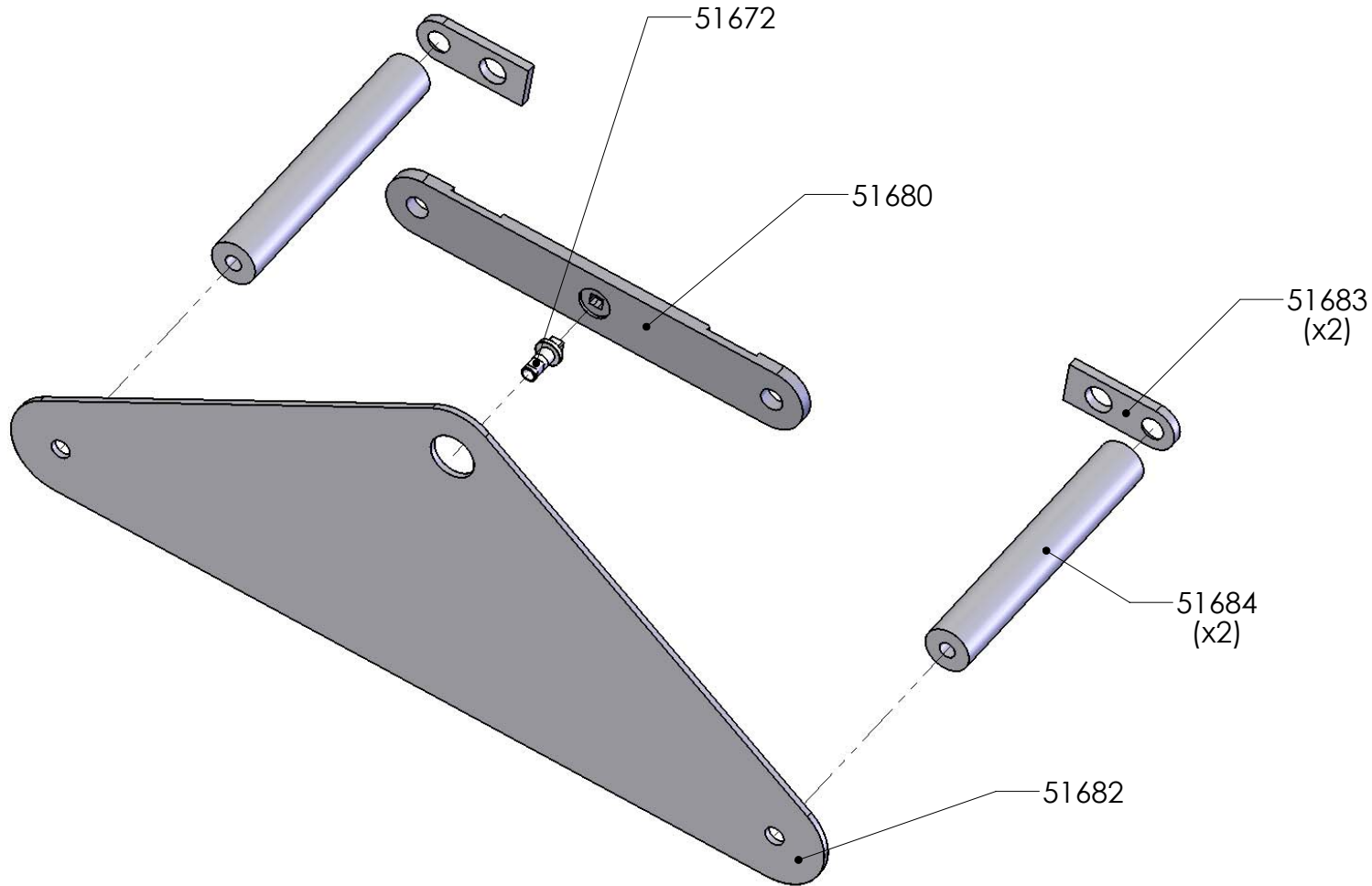

- Note:
- 1.) use drive joint: 32002
  - 2.) use flex shaft: 06001-2.58
  - 3.) standoffs use 3/8" hardware

TOLERANCES:		<b>GLENDINNING MARINE PRODUCTS INC.</b> 740 CENTURY CIRCLE, CONWAY SC 29526 PH 843 399 646 FAX 843 399 5005
LINEAR:	ANGULAR:	
FRACTION ±0.015"	0 DEC PL ±1.00°	
2 DEC PL ±0.010"	1 DEC PL ±0.05°	
3 DEC PL ±0.005"		
4 DEC PL ±0.001"		

SURFACE FINISH	32 GROUND 125 MACHINED 250 CAST	ALL DIMENSIONS ARE IN INCHES, UNLESS OTHERWISE SPECIFIED DO NOT SCALE DRAWING		Adapter - 3412E CAT		
MATERIAL	Stainless Steel	APPROVALS	DATE	DWG NO.		
		DRAWN		06075		
		JT	1/30/06	SIZE	SCALE	REV.
FINISH	None	CHECKED		A	1:3	A
		PG	1/30/06			

