

THE INFORMATION CONTAINED IN THIS DRAWING IS THE SOLE PROPERTY OF Glendinning Marine Products Inc. ANY REPRODUCTION IN PART OR WHOLE WITHOUT THE WRITTEN PERMISSION OF Glendinning Marine Products Inc. IS PROHIBITED.

REV	DESCRIPTION	ECN #	INIT	DATE
A	INITIAL RELEASE	2942Fq	DWJ	8/26/05

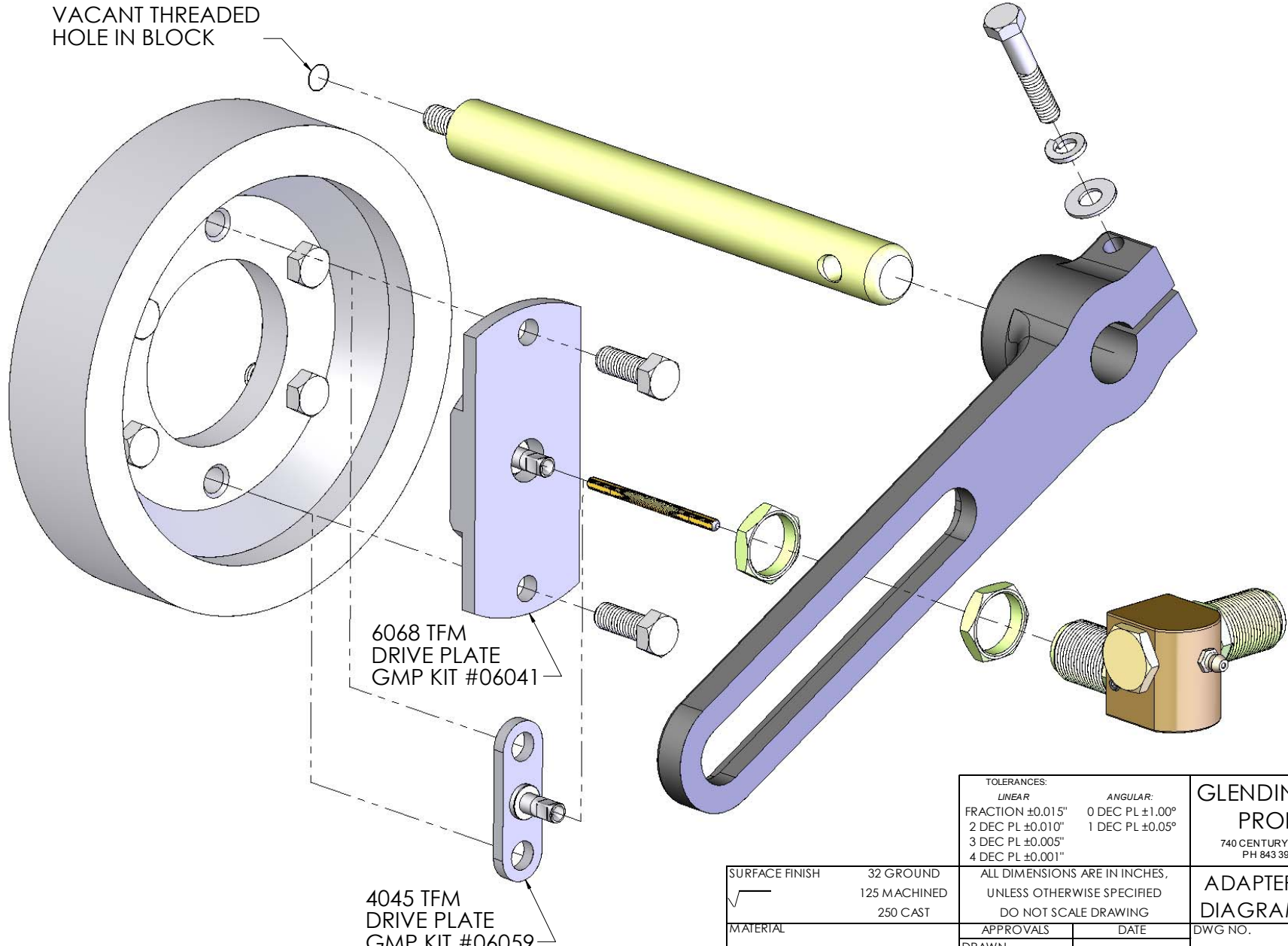

TOLERANCES:	
LINEAR	ANGULAR:
FRACTION $\pm 0.015''$	0 DEC PL $\pm 1.00^\circ$
2 DEC PL $\pm 0.010''$	1 DEC PL $\pm 0.05^\circ$
3 DEC PL $\pm 0.005''$	
4 DEC PL $\pm 0.001''$	

**GLENDINNING MARINE PRODUCTS INC.**  
 740 CENTURY CIRCLE, CONWAY SC 29526  
 PH 843 399 6466 FAX 843 399 5005

SURFACE FINISH	32 GROUND	ALL DIMENSIONS ARE IN INCHES, UNLESS OTHERWISE SPECIFIED DO NOT SCALE DRAWING	APPROVALS		DATE
	125 MACHINED		DRAWN	8/26/05	
250 CAST	DWJ				
MATERIAL		CHECKED			

DWG NO.		
SIZE	SCALE	REV.
A	NTS	A

**ADAPTER INSTALLATION DIAGRAM - JOHN DEERE**