

MECHANICAL TACH DRIVE

For 300 hp Cummins 6BT5.9M2

Kit #EI 9008 or DF-9037

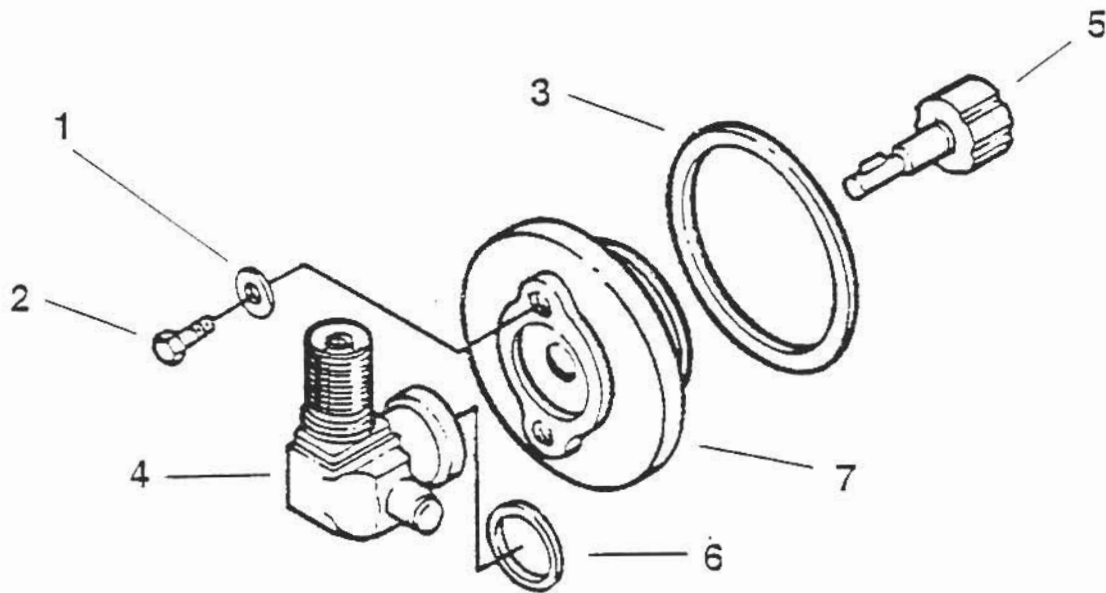

Ref. No.	Part Number	Part Name	Req	Remarks
		MECHANICAL TACH DRIVE OPTION		Mechanical tachometer drive with 90 degree adapter. Mounted on gear cover and oriented 30 degrees clockwise from vertical as viewed from the front of engine. .187" Tang drive.
1	62392	Washer, Plain	2	
2	3027685	Screw, Hexagon Head Cap	2	M6 x 1.00 x 12
3	3903475	Seal, Rectangular Ring	1	
4	3914132	Adapter, Angle Drive	1	
5	3917333	Hub, Tac Drive Coupling	1	
6	3915800	Seal, Rectangular Ring	1	
7	3918215	Adapter, Tac Takeoff Drive	1	

MECHANICAL TACH DRIVE

This rap is removed
and adapter goes here.

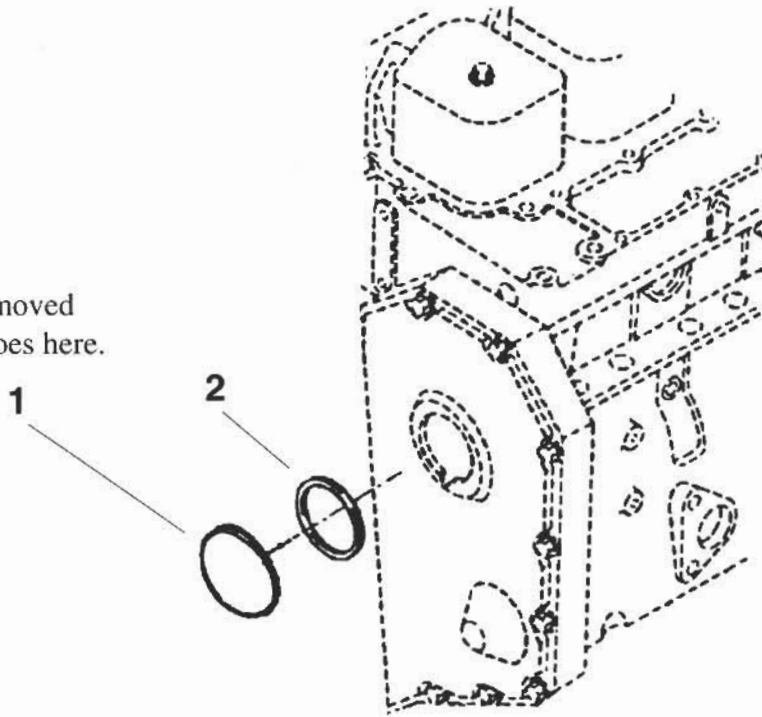

Ref. No.	Part Number	Part Name	Req	Remarks
		MECHANICAL TACH DRIVE OPTION E19701		Accessory hole cover tube used when no mechanical tach drive or front oil fill is used.
1	3903463	Cover, Access Hole	1	
2	3903475	Seal, Rectangular Ring	1	