

THE INFORMATION CONTAINED IN THIS DRAWING IS THE SOLE PROPERTY OF Glendinning Marine Products Inc. ANY REPRODUCTION IN PART OR WHOLE WITHOUT THE WRITTEN PERMISSION OF Glendinning Marine Products Inc. IS PROHIBITED.

REV	DESCRIPTION	ECN #	INIT	DATE
△				

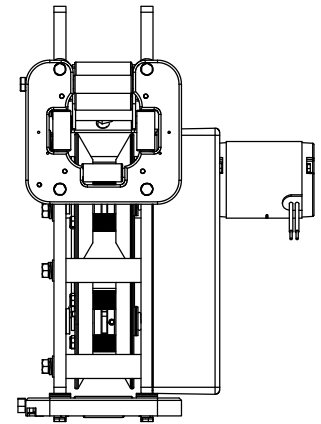
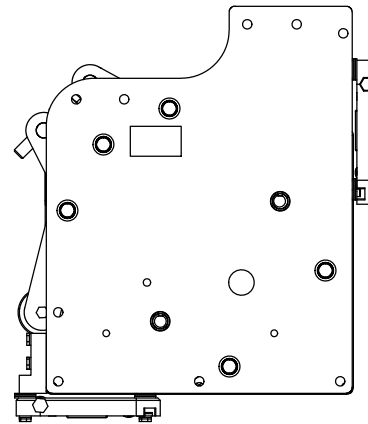
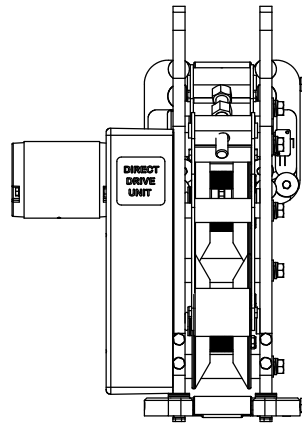
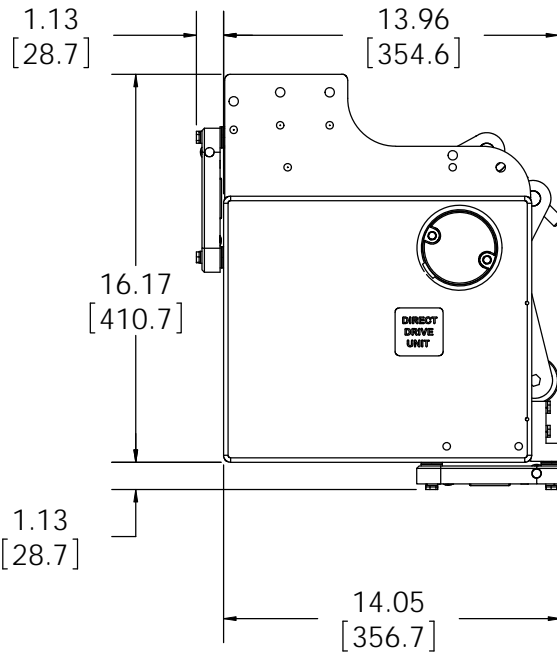
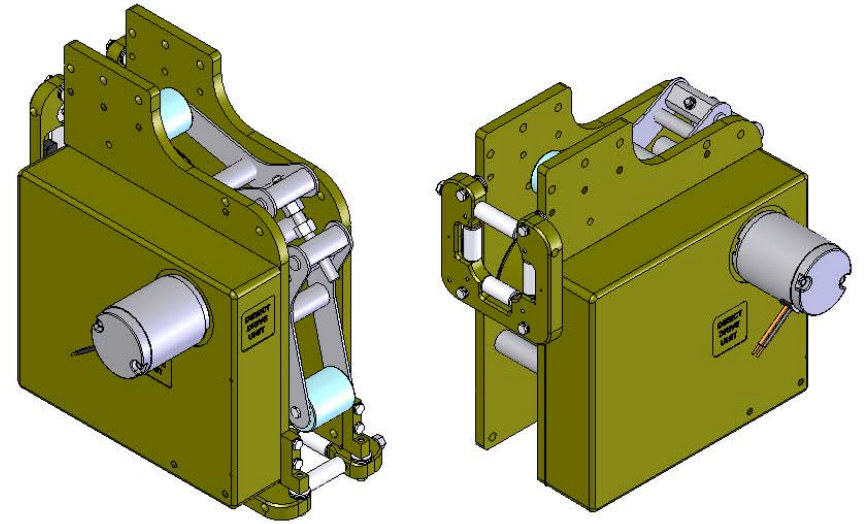
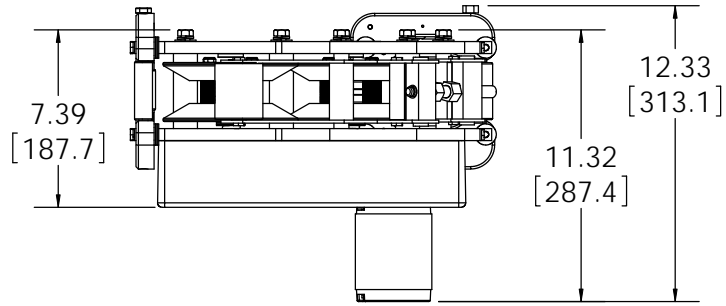

TOLERANCES:		<b>GLENDINNING MARINE PRODUCTS INC.</b> 740 CENTURY CIRCLE, CONWAY SC 29526 PH 843 399 6146 FAX 843 399 5005
LINEAR	ANGULAR:	
INCHES[mm]	0 DEC PL ±1.00°	
2 DEC PL ±.010[.25]	1 DEC PL ±0.50°	
3 DEC PL ±.005[.13]		

SURFACE FINISH	32 GROUND	ALL DIMENSIONS ARE IN INCHES, UNLESS OTHERWISE SPECIFIED DO NOT SCALE DRAWING	CM9		
	125 MACHINED		DWG NO. <b>04097</b>		
250 CAST	APPROVALS				
MATERIAL		MMR	3/14/11	A	1:8
FINISH		CHECKED			REV. -