

- 1 - Remove all internal parts from housing, except gear shafts.
- 2 - Clean out all the original grease from housing. (The main reason for this is to remove any broken gear parts from the housing.)
- 3 - Install .03" spacer (#72406) onto each shaft, Make sure the original spacers have been removed, or just leave them on the shaft, and do not add anymore spacers as mentioned above.

- 4 - Install new Cluster Gear A (#WP053) onto shaft

- 5 - Install original Cluster Gear B (WP052) onto shaft with small gear toward housing

- 6 - Install .03" Spacer (#72406) and .406" spacer (#51422) onto shaft with Cluster Gear B

- 7 - Install .03" Spacer (#72406), new Pivot Gear Assembly (#WP010), and another .03" Spacer (#72406) onto shaft with Cluster Gear A

- 8 - Install Main Shaft Gear Assembly (#WP125) into main shaft bearing

- 9 - Install New gearbox Gasket GMP # 87404

- 10 - Add new grease around all gears

- 11 - Install Gearbox cover (not shown) and 8/32 hex screws (some extra screws supplied)

- 12 - Run unit and confirm that under no load the motor current is only 1 - 2 amps.

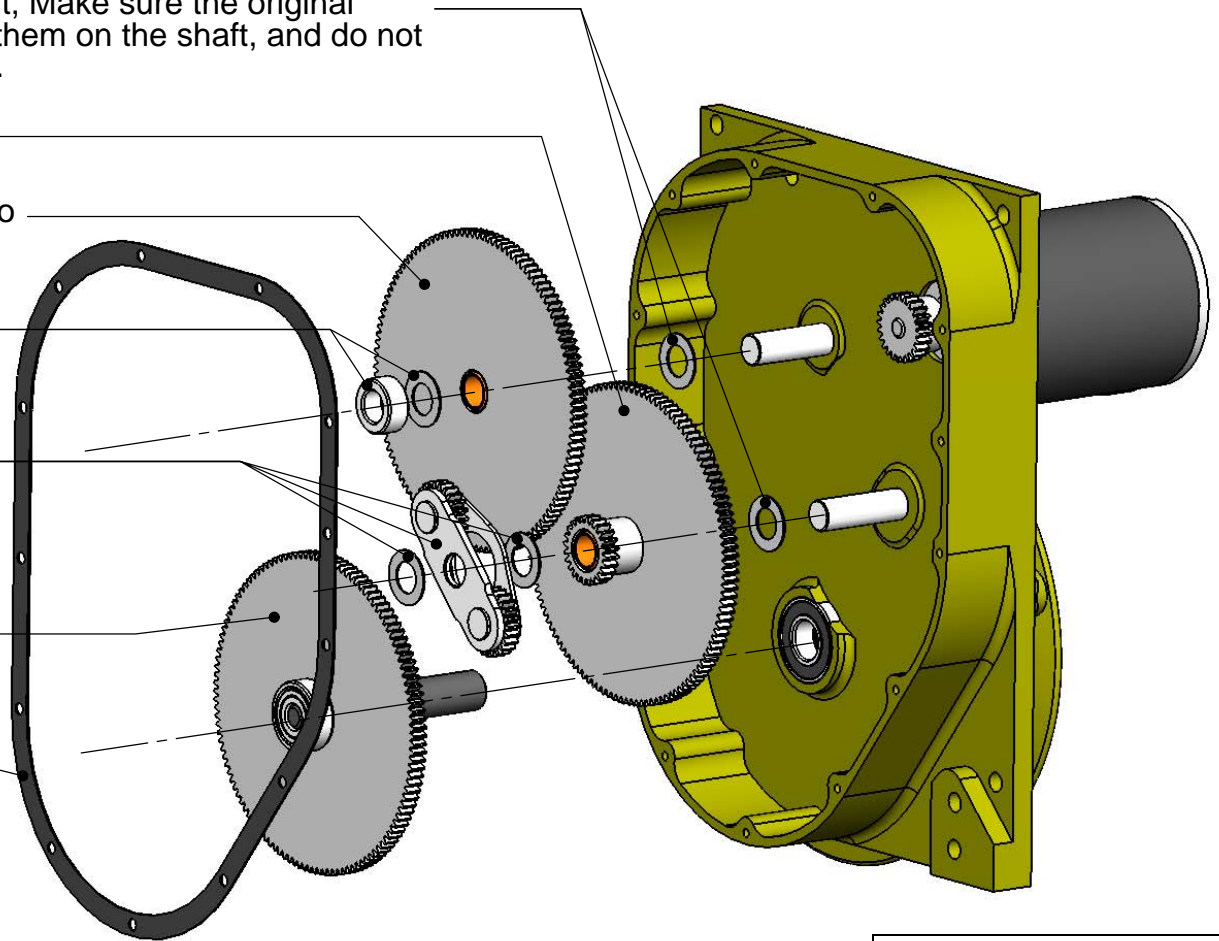

GLENDINNING MARINE
PRODUCTS INC.

740 CENTURY CIRCLE, CONWAY SC 29526
PH 843 399 6146 FAX 843 399 5005

CM-7 Pivot Gear rebuild kit
and assembly Instructions

DWG NO.

GMP Part # WP066

SIZE	SCALE	REV.
------	-------	------

DRAWN BY PG	DATE 7/1/2009
----------------	------------------