

**Smart Actuator
Installation & Operation Manual** v3.4e

Complete Controls *by Glendinning*



*WARNING: DISCONNECT SYSTEM'S GROUND AND BONDING
BEFORE ANY WELDING ACTIVITY ON BOARD VESSEL!*



Glendinning Marine Products, Inc.
740 Century Circle
Conway, SC 29526
(843) 399-6146
Fax: (843) 399-5005
www.glendinningprods.com

MANUAL REVISIONS

REVISION	PAGE #	DESCRIPTION	DATE of CHANGE
3.4e	101	Added Section 7.8 - Triple Engine Applications (optional) to the Appendix section of the manual	JANUARY 2007
3.4d	33, 36	Fixed troubleshooting example; Added missing alarm code for CP lost communication with Actuator #6	DECEMBER 2006
3.4c	100	Relocated Section 4.2 to Appendix and labelled as Section 7.7.4 - To Set Cable Direction Only	NOVEMBER 2006
3.4b	21	Added instructions for wiring the Tachometer Sender to the Smart Actuator	OCTOBER 2006
3.4a	30	Added Section 4.3 - Calibration Verification	AUGUST 2006

Chapters at a Glance

1.0	System Description & Capabilities	1
1.1	System Components	1
1.2	System Layout	3
2.0	Operating the Smart Actuator	5
2.1	System Startup	5
2.2	Cruise Mode	6
2.3	Warm Up Mode	8
2.4	Slow Mode	9
2.5	Automatic Synchronization Mode	10
2.6	Troll Mode	11
2.7	Station Transfer Process	11
2.8	Warning Mode	13
2.9	Alarm Mode	13
3.0	Installing the Complete Controls	15
3.1	Pre-Installation Planning	15
3.2	Engine Compartment - Mount the Smart Actuator	18
3.3	Engine Compartment - Control Cable Connections	18
3.4	Engine Compartment - Electrical Connections	20
3.5	Mounting the Control Head	22
4.0	Smart Actuator Calibration	25
4.1	Calibrating Actuator Endpoints & Cable Direction	26
4.2	Calibration Verification	28
5.0	System Test & Checkout	29
5.1	Component Installation Checks	29
5.2	Operational Checks	29
6.0	Troubleshooting Mode	31
6.1	To Retrieve Alarm Count and/or Alarm Codes	31
6.2	To Delete Alarm Codes and Exit Handle Troubleshoot Mode	32
6.3	To Exit Handle Troubleshoot Mode	32
7.0	Appendix / References	39
7.1	Wiring Diagrams	41
	SINGLE Engine Wiring Diagram	41
	TWIN Engine Wiring Diagram	42
	TWIN Engine w/TROLL Wiring Diagram	43
	TWIN Engine w/ELECTRIC GEAR Wiring Diagram	44
	Smart Actuator Harnesses	45
7.2	Dimensional Drawings / Cutout Templates	49
	Actuator Dimensions	49
	2-button Control Head (Remote) Dimensions	50
	2-button Control Head CP Dimensions	51
	4-button Control Head (Remote) Dimensions	52
	4-button Control Head CP Dimensions	53
	Smart Actuator Mounting Dimensions	54
	Cutout Templates for Control Heads	55
7.3	Mechanical Backup Control (optional)	59
7.4	Sidemount Control Head (optional)	71
7.5	Control Head Configuration (setting handle IDs)	79



7.6 Control Processor Configuration81

7.6.1 Actuator Options82

7.6.2 Throttle on Top of Troll Options83

7.6.3 Troll Delay Options84

7.6.4 Throttle Delay Options85

7.6.5 Gear Delay Options85

7.6.6 High-Idle Step Size (pt. 1)87

7.6.7 High-Idle Step Size (pt. 2)88

7.6.8 System Startup Options89

7.6.9 Station Transfer Options90

7.6.10 Return System to Defaults Option91

7.6.11 Sync Gain Options92

7.6.12 Mechanical Backup Options93

7.7 Smart Actuator Configuration95

7.7.1 Setting Actuator Defaults Option95

7.7.2 Setting Actuator Identifier96

7.7.3 Setting Tachometer Pulses / Revolution (PPR)97

7.7.4 Setting Cable Travel Direction ONLY98

7.8 Triple Engine Application (optional)101

 TRIPLE Engine Wiring Diagrams102

 TRIPLE Engine Harnesses103

A word about the Symbols used in the Manual

When driving from one destination to another, road signs prove to be invaluable. Road signs are an important source of information. For example, road signs can warn you about potential problems ahead to help divert certain disaster or they can let you know where to turn off for a rest or a meal.

In an effort to help you navigate your way through this manual we will from time to time use the following symbols:



Throughout the manual the NOTES symbol will appear to support what has been mentioned in the text. A note can be used where further explanation is needed or where something needs highlighting. BE CAREFUL to read all NOTES.



Sometimes it is helpful to take a break and really absorb what you just read. The WARNING symbol will alert the reader to information that needs to be completely understood before you continue on in the reading of the manual. ALWAYS STOP and READ these points.



The TIP symbol will be used when something mentioned in the text need more “light” shed on it. The tip could explain or be a list of do’s and don’ts. Whatever the TIP is, you do not want to miss out on the information it contains.

1.0 System Description & Capabilities

With the advent of electronically controlled engines in the marine industry, *GLENDINNING* has developed the Complete Controls System to be compatible with all types of electronically & mechanically governed engines and will provide the boat operator with total control over the boat's propulsion system. The Complete Control System incorporates the following standard features:

- *Single lever control from up to 6 control stations* — Single lever control permits gear and throttle control using a single control lever. The Complete Controls control processor correctly sequences the operation of engine and transmission, so that the engine and transmission are protected during shifting at up to 6 separate helm control stations. Only one station is in control of the propulsion plant at any time.
- *Adjustable control head detent / friction settings* — This feature allows for the setting of the control head detent and/or friction quickly and easily while underway, without disassembling the control head!
- *“Posi-lock” gear lockout* — A dedicated button (WARM) is provided to lockout the gear and allows engine RPM to be increased safely.
- *Battery voltage warning indicator* — Our system alerts you when either too low or too high voltage exists. The control system will continue to operate as long as possible, within the limits of its operating voltage.
- *System diagnostic warning indicator* — The Complete Controls System monitors many parameters and notifies you when conditions fall outside suitable operating range.
- *Neutral gear position indicating lights* — You know that the transmission has shifted into neutral gear with this visual gear position indicator.
- *Two button station transfer* — No more accidental transfer of control from one station to another. Our system's TAKE button must be depressed twice in order to transfer control from one station to another.
- *Control Head Lights Dimmer* — This feature allows the LED brightness on the control head keypad to be dimmed for night operation.

In addition to these standard features, the Complete Controls system includes the following optional features that are available with the upgraded 4-button control head:

- *Adjustable control head detent / friction settings* — This feature allows for the setting of the control head detent and/or friction quickly and easily while underway, without disassembling the control head!
- *High idle mode* — Up to 10 idle speeds are available and can be adjusted through system calibration.
- *Bump mode* — Want to make minute adjustments in engine speed (approx. 10-15 RPM)? Simply press the WARM or TROLL buttons!
- *Slow mode* — Limits maximum RPM available to approximately 50% of normal WOT. Very useful for maneuvering or slow speed cruising (SLOW).
- *Gear position indicating lights* — You know that the transmission has shifted into the appropriate gear with this visual gear position indicator.
- *Control head light dimmer* — Bright lights are great for daylight conditions, but can be distracting at night. This feature allows you to dim the control head lights for each station individually.

1.1 System Components

The Complete Control System consists of 4 separate components. They are:



4-Button
Control Head



2-Button
Control Head



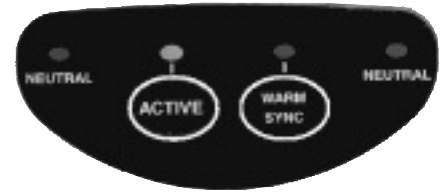
Single Engine
Control Head

Control Head

The Control Head is by far the most informative control head in the industry today. The control head keypad has integrated switches and indicator lights which allow the boat operator to control all aspects of the boat's propulsion system.

Robust, watertight construction is a hallmark at *Glendinning* — we build our control heads to withstand the extreme conditions that exist in the marine environment.

2-BUTTON KEYPAD
(Close-up)



4-BUTTON KEYPAD
(Close-up)

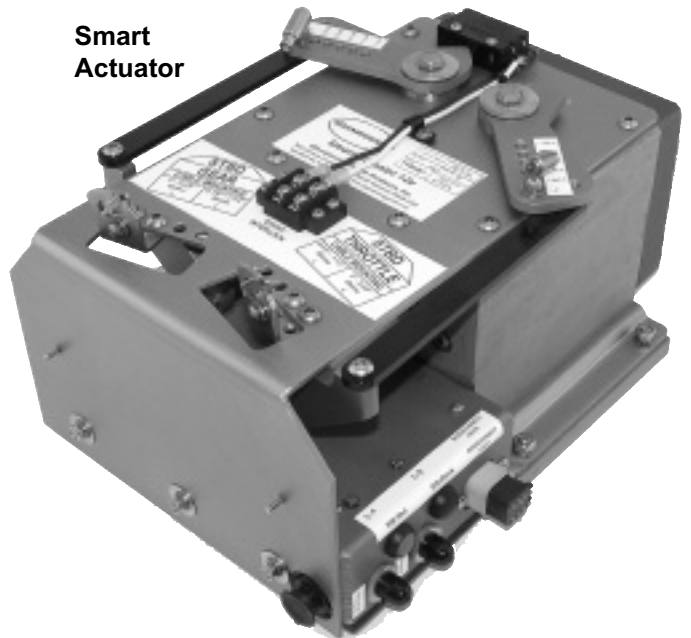


OPTIONAL Handheld Remote Control allows boat operator to control both throttle and transmission from almost anywhere on board his vessel.

Smart Actuator

The electromechanical actuators convert the electronic commands that are generated by the control head into specific positions at the engine gear, throttle and trolling valve. The actuators are housed in rugged, corrosion resistant, aluminum enclosures that are sealed to eliminate problems which may be caused by exposure to the marine environment. The actuator motor drive assembly uses precision ground steel gears and components that are manufactured to very precise tolerances. Combined with a high frequency pulse width modulation (PWM) input, the actuator is able to resolve a linear position of less than 0.010 inch very smoothly with no "steps."

Smart Actuator

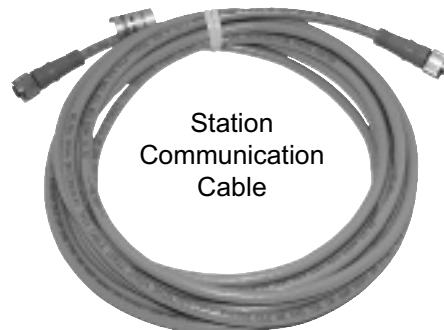


Station Cables

Glendinning's station cables are pre-terminated at the factory for ease of installation, and are completely shielded to eliminate problems caused by electromagnetic interference, complying with the latest and strictest standards in the industry. Both ends of the station cable has a connector which is identical on either end—no mistakes when it comes to plugging in the cable!

Engine / Gear Harnesses

The engine and gear harnesses relay information from the control processor to the engine and gear controls. Connecting your gear and engine to the Control Processor has never been easier. Each engine harness and/or gear harness is clearly labelled and simply plugs into the appropriately labelled port on the control processor.



Station Communication Cable

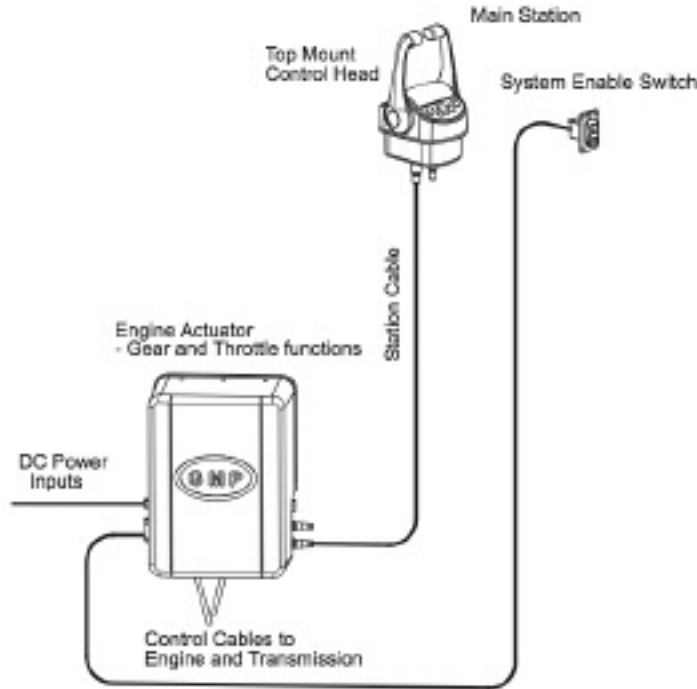


CLOSE-UP Station Communication Cable Connector

1.2 System Layout

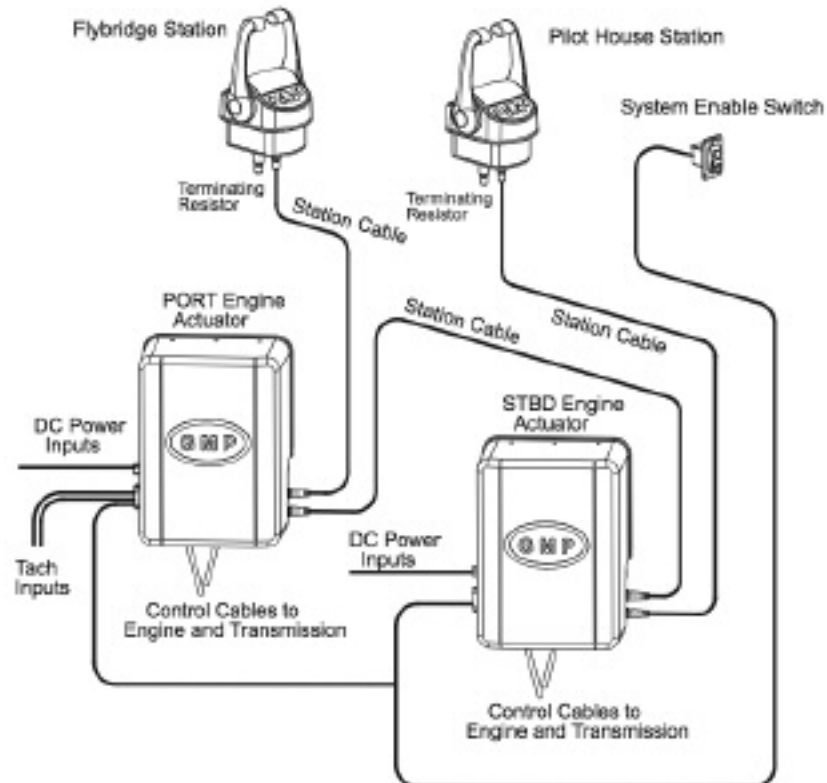
Single Engine

- Mechanically controlled engine and transmission
- Single Station



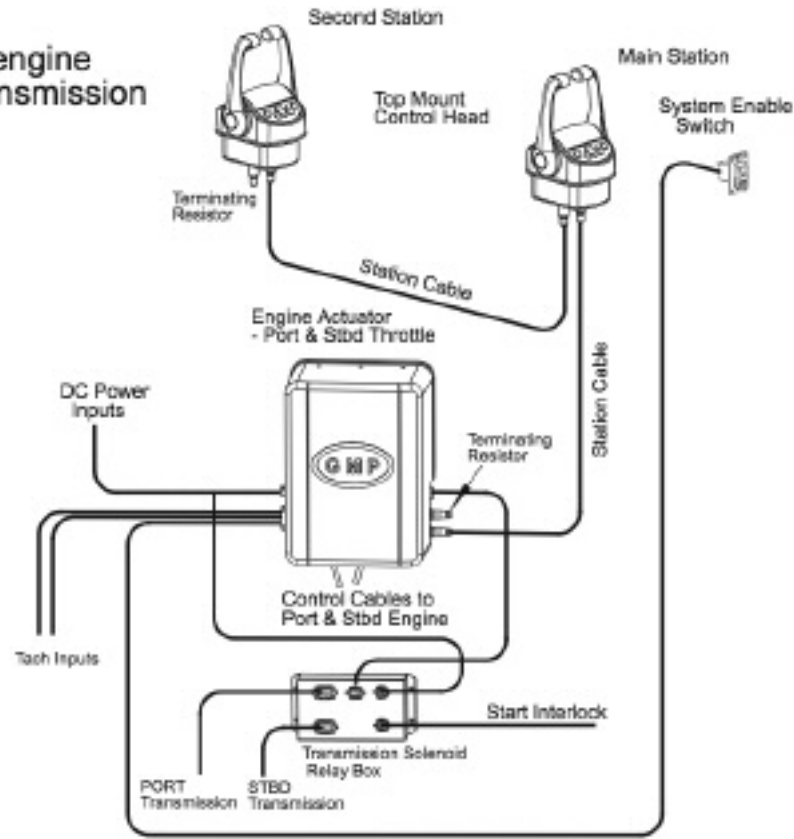
Twin Engine

- Mechanically controlled engine and transmission
- Twin Station



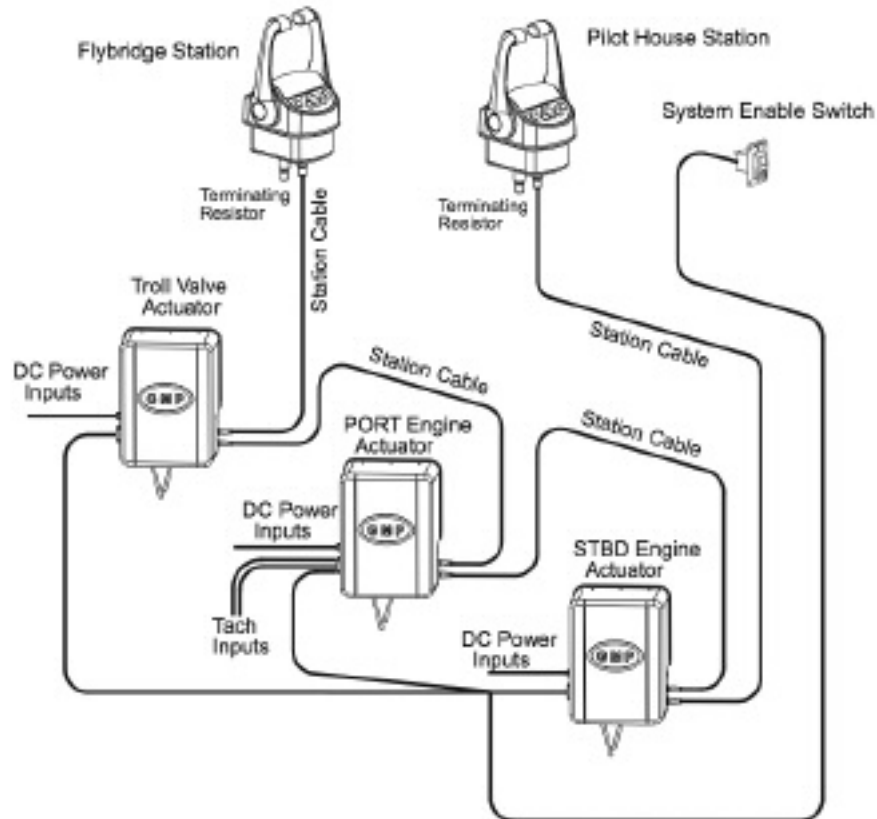
Twin Engine

- Mechanically controlled engine
- Electrically controlled transmission
- Twin Station



Twin Engine with Trolling Valves

- Mechanically controlled engine and transmission
- Twin Station
- Trolling Valves



2.0 Operating the Smart Actuator

Operating the Smart Actuator is just as easy as the installation process. The Control Head will constantly monitor various parameters and will alert the boat operator if the system falls outside the normal operating range.

Familiarize yourself with the following functions BEFORE operation.

The functions necessary for operating are:

- System Startup Procedure
- Cruise Mode
- Warm Up Mode
- Automatic Synchronization Mode
- Station Transfer Process
- Warning Mode
- Alarm Mode

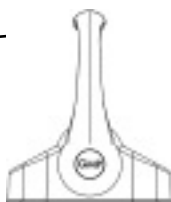
2.1 System Startup

The procedure for starting up the system is as follows:

1. Control Handles must be in the NEUTRAL position prior to starting the system.
2. Turn ON the system enable switch. The system will perform a brief diagnostic test (approx. 1 second), checking various system parameters (indicated by the TAKE light fully illuminated). Control handles should remain in **NEUTRAL** until system is operational.
3. The system is operational when the TAKE light and WARM lights are fully illuminated (not blinking). The system is automatically placed in WARM Mode at startup (This feature can be turned OFF if desired, see sec 4.0).

Step 1

Position control handle to Neutral before starting the system



Step 2

Turn system ON.

System will perform a brief diagnostic test indicated by these keypad lights being fully illuminated.

2-BUTTON KEYPAD



4-BUTTON KEYPAD



Step 3

System is fully operational when you see these keypad lights fully illuminated (not flashing).

2-BUTTON KEYPAD



4-BUTTON KEYPAD





If the TAKE light (4-button keypad) or the ACTIVE light (2-button keypad) flashes slowly, accompanied by a slow beep, the control handles are not in NEUTRAL. Leave control system enable switch on and move one control handle at a time to verify that handles are in the neutral position. When both handles are in NEUTRAL, system will automatically complete startup procedure (TAKE light or ACTIVE light fully ON).

2-BUTTON KEYPAD



If these lights are flashing during startup — leave system ON and move each control handle to verify that it is in NEUTRAL

4-BUTTON KEYPAD



If all four (4) lights on the keypad blink in unison, the EEC system is in Alarm Mode. Restart the system by turning OFF the system enable switch and then turning back ON.

2-BUTTON KEYPAD



If these lights are flashing during startup — system is in Alarm Mode — Restart of system is required

4-BUTTON KEYPAD



2.2 Cruise Mode

Cruise Mode is the normal operating mode. Other functions may be accessed while in Cruise Mode (see below):

The Control Head may respond in one of three ways during Cruise Mode:

1. **ACTIVE STATION** — During normal operation only the active station will be in command. ACTIVE or TAKE light will be fully illuminated (not flashing) indicating that the station is “active” and in command of boat’s propulsion system.

2-BUTTON KEYPAD



ACTIVE light is ON (not flashing) at station that is in control

4-BUTTON KEYPAD



TAKE light is ON (not flashing) at station that is in control

2. **INACTIVE STATION** — During normal operation all other stations are “inactive”. The ACTIVE light or TAKE light and Gear positioning lights on each inactive station will blink every 2 seconds indicating that the control head is an inactive station. The Check Battery/Check System lights will operate.

2-BUTTON KEYPAD



ACTIVE light is flashing at station that is INACTIVE

4-BUTTON KEYPAD



TAKE light and gear indicator lights flash at station that is INACTIVE

3. **ALARM MODE** — During normal operation, the system continuously monitors parameters and will alert operator of alarm conditions when they exist. Alarm Mode is indicated by all four (4) keypad lights blinking in unison.

2-BUTTON KEYPAD



All 4 lights flashing in unison indicates system is in ALARM Mode

4-BUTTON KEYPAD



All 4 lights flashing in unison indicates system is in ALARM Mode

Other Functions available from Cruise Mode are:

1. **THROTTLE “BUMP” MODE** — During normal operation, small changes in engine speed (approximately 10-15 RPM) may be made by pressing and releasing the buttons described below for your keypad style.

Engine speed can only be “bumped” when control handles are in gear or above idle speed. Amount of speed change per bump can be adjusted during system calibration.

2-BUTTON KEYPAD



Press and Release ACTIVE button



Press and Release ACTIVE & WARM button

To INCREASE engine speed by using Bump Mode

4-BUTTON KEYPAD



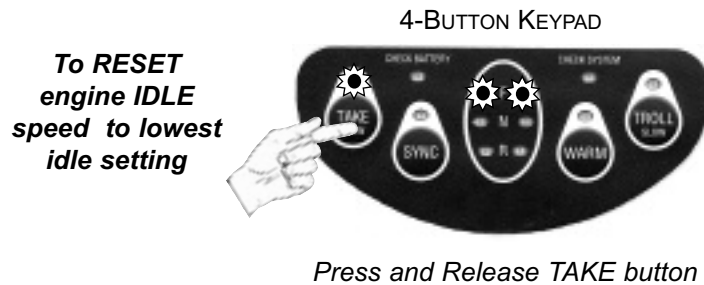
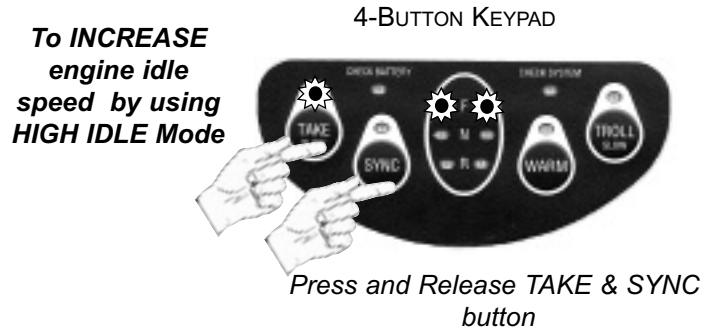
Press and Release WARM button

To DECREASE engine speed by using Bump Mode



Press and Release TROLL button

2. HIGH IDLE MODE — (*HIGH IDLE MODE is only available with our 4-Button Keypad*) During normal operation, the boat operator is able to change the engine idle speed up to 10 different idle speed settings.



Engine idle speed can only be changed while control handles are in NEUTRAL or Gear Idle Detent. Idle speed change can be adjusted during system calibration.

2.3 Warm Up Mode

Warm up Mode allows the boat operator to operate the engine throttle by itself, while locking the transmission in NEUTRAL. It is **STRONGLY RECOMMENDED** that the system be in Warm Up Mode **AT ALL TIMES** while boat is at the dock! This safety procedure will prevent the accidental engagement of transmission if the control head handles are inadvertently moved.

To utilize the Warm Up feature:

1. To engage, press and release the WARM button one time (control handles must be in NEUTRAL position to engage Warm Up Mode).
2. Advance the control lever into and beyond the Ahead detent position. The engine gear will remain in NEUTRAL while engine speed is increased.
3. To disengage, bring handles back to NEUTRAL and press and release the WARM button one time.

Step 1

Position control handle to Neutral before entering WARM Mode



Step 2

To ENGAGE, press & release the WARM button one time. WARM light will be ON and engine speed may be increased while gear is "locked" in NEUTRAL.

2-BUTTON KEYPAD



4-BUTTON KEYPAD



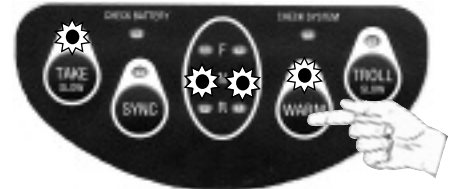
Step 3

To DISENGAGE, make sure control handles are in the NEUTRAL position and press & release WARM button one time. WARM light will be OFF.

2-BUTTON KEYPAD



4-BUTTON KEYPAD



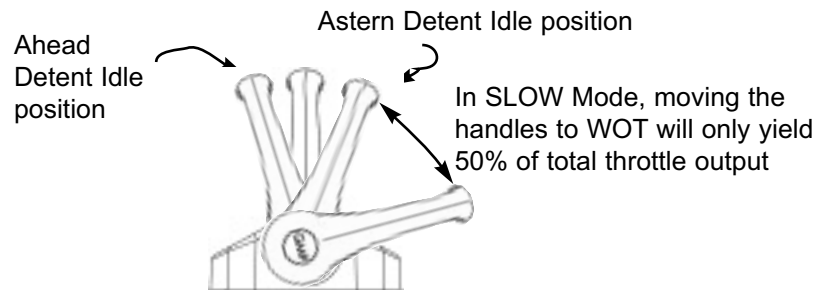
2.4 Slow Mode (only available on 4-button keypad)

The Slow Mode limits the maximum RPM available to approximately 50% of normal WOT. This feature is very useful for maneuvering or slow speed cruising.

The Slow Mode is activated by:

1. To engage, press and release TAKE and TROLL buttons in unison, one time. Control handles must be in NEUTRAL position to engage Slow Mode.
2. To disengage, press and release TAKE and TROLL buttons in unison, one time. Control handles must be in NEUTRAL position to disengage Slow Mode.

In order to activated the Slow Mode, control handles must be in NEUTRAL position



4-BUTTON KEYPAD

To ENGAGE, press & release TAKE & TROLL buttons in unison. When activated the TAKE & TROLL light will flash and moving handles to WOT will only yield 50% of total throttle output



To DISENGAGE, press & release TAKE & TROLL buttons in unison. TROLL / SLOW light will go OFF and system will revert to Normal operation

4-BUTTON KEYPAD



2.5 Automatic Synchronization Mode

The Automatic Synchronization Mode allows the control system to automatically control one engine speed to exactly match speed of the other engine. Think of it as cruise control for your boat. Once underway, follow the instructions below to activate this feature and control both engines' speed with one handle.

To activate the Automatic Synchronization Mode:

Before the SYNC function can engage, both engines must be in the Ahead gear and handles must be approximately matched — within 10% of total travel.

1. Press and release the SYNC button one time.
2. When SYNC function is energized, system will automatically control one engine speed to match the speed of the other engine. If engine speed is changed manually by the boat operator, engine speed will automatically be changed to match.
3. To disengage, bring slave handle to match position of lead engine control handle and press and release SYNC button one time. *It is extremely important that the slave handle is brought back to a position relative to the lead handle prior to disengaging.*

2-BUTTON KEYPAD



Press and Release SYNC button one time

4-BUTTON KEYPAD



Press and Release SYNC button one time



Press and Release SYNC button one time

To disengage engine SYNC Mode, move slave engine control handle to approximately match position of lead engine



Press and Release SYNC button one time



1. Synchronization mode will be automatically disengaged if both control handles are moved to NEUTRAL position together.

2. If lead handle is moved to NEUTRAL gear position by itself, synchronization mode will be automatically de-energized. Slave engine operation will continue to match lead engine operation (gear and throttle) until slave control handle is matched to lead control handle position.

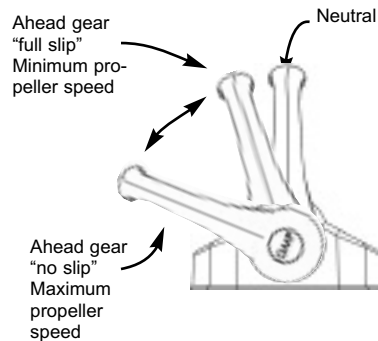
2.6 Troll Mode (only available on 4-button keypad)

The Troll Mode is available only if the boat has been equipped with trolling valves and allows the boat operator to control the position of the transmission trolling valves.

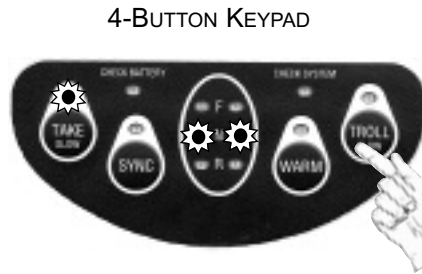
To activate Troll Mode:

1. With control handles in NEUTRAL, press and release TROLL button one time (control handles must be in NEUTRAL to engage Troll Mode).
2. Control troll valve position by movement of control handle. Engine throttle speed is maintained at idle while system is in Troll Mode.
3. To disengage, move control handles back to NEUTRAL and press and release TROLL button one time.

In order to activate the Troll Mode, control handles must be in NEUTRAL position



To ENGAGE, press & release the TROLL button. When activated the TROLL light will be ON and moving handles will control troll valve position



To DISENGAGE, press & release the TROLL button. TROLL light will go OFF and system will revert to Normal operation



2.7 Station Transfer Process

The Complete Control System allows the propulsion system control to be transferred from one control station to another control station. This process requires the operator to depress the ACTIVE or TAKE button twice in order for the transfer to take effect thus avoiding any inadvertent transfers from taking place without the boat operator's knowledge.

To transfer control follow these steps:

1. Press and release ACTIVE or TAKE button one time, at the helm station where you want to take control (ACTIVE or TAKE light will begin to blink and control head beeper will begin to sound).



Press & Release ACTIVE button one time to begin the station transfer process

At INACTIVE station



Press & Release TAKE button one time to begin the station transfer process

2. At the station where you want to take control, move the control handles to an appropriate throttle position.

Active Station Handle Position	Station Taking Control Handle Position
In Neutral	In Neutral
In gear, at Idle	In Neutral, or same gear position at Idle
In gear, above Idle	In Neutral, or same gear position at same or lower speed setting

ADJUST CONTROL HANDLES
(see chart at left)

3. Press and release ACTIVE or TAKE button a second time. The new control station is now the active station and has control of the engine and transmission.

2-BUTTON KEYPAD

Press & Release ACTIVE button one more time to complete the station transfer process

4-BUTTON KEYPAD

At INACTIVE station

Press & Release TAKE button one more time to complete the station transfer process

See the illustrations below for the light sequence at the INACTIVE station's keypad:

2-BUTTON KEYPAD

Light flashes 1 time every 2 seconds

Prior to pressing button, light flashes 1 time every 2 seconds (inactive station heartbeat)

4-BUTTON KEYPAD

Slow flash — handles not in appropriate position

Quick flash — handles in appropriate position

After pressing button 1 time, ACTIVE or TAKE light will flash depending on handle setting at control station taking control

Solid ACTIVE or TAKE light indicates transfer complete

Control transfer is complete when ACTIVE or TAKE button is pressed a second time while light quick flashes

2.8 Warning Mode

During operation of the Complete Control System, the system will warn the operator when a problem is detected. System will continue to operate in unaffected functions.



2-BUTTON KEYPAD



If a warning occurs while operating the 2-button keypad, whatever system light is ON at the time of the warning will flash 3 times then pause and repeat

System will continue to operate in unaffected functions

4-BUTTON KEYPAD

<p><i>CHECK BATTERY light blinks</i></p>  <p>CHECK BATTERY INDICATOR will blink when battery voltage conditions exist that are questionable.</p>	<p>SYMPTOM</p> <ol style="list-style-type: none"> 1) <i>SLOW BLINK</i>—Batteries are too low. 2) <i>QUICK BLINK</i>—Batteries are too high. 	<p>ACTION</p> <ol style="list-style-type: none"> 1) Determine cause of input power problem. 2) System will continue to operate normally, unless battery exceeds system parameters. If this occurs system will be switched into Alarm Mode (see page 10).
<p><i>CHECK SYSTEM light blinks</i></p>  <p>CHECK SYSTEM INDICATOR will blink when a possible problem has been detected within the system.</p>	<p>SYMPTOM</p> <ol style="list-style-type: none"> 1) Diagnostics tests have detected that part of the control system is not functioning normally. 	<p>ACTION</p> <ol style="list-style-type: none"> 1) Restart control system (turn OFF/ON). Move handles to Neutral during system startup. 2) Determine part of system not operating properly (ie. gear, throttle, troll, etc.). 3) Utilize alarm code recovery procedure to discover source of problem (see Operations Guide).

2.9 Alarm Mode

During operation, the system continuously monitors system functions and will alert operator if a system problem has been detected. When Alarm Mode is activated, control system will not continue to operate. In absence of control signal from the system, transmission will normally go to NEUTRAL and engine throttle will normally go to IDLE.

2-BUTTON KEYPAD

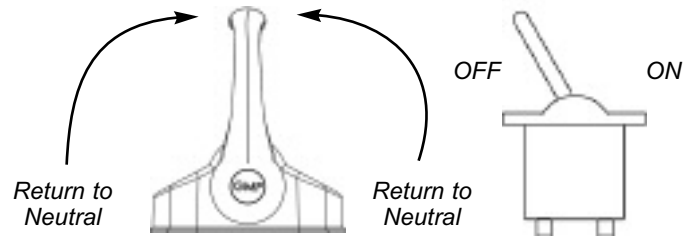


ALARM IS INDICATED when all 4 lights are blinking in unison on the control keypad.

4-BUTTON KEYPAD



Return the main station control handles to NEUTRAL and turn system power switch OFF. Restart the system.



3.0 Installing the Complete Control — Smart Actuator

Installing the Complete Control System is simple and easy. It is always important that proper care be given when installing any equipment on board your vessel. It is always a wise practice before cutting into the ship's interior to follow the old adage "measure twice, cut (or drill) once!"

The installation process includes the following:

- Pre-installation Planning
- Engine Compartment — Mount the Smart Actuators
- Engine Compartment — Control Cable Connections
- Engine Compartment — Electrical Connections
- Mounting the Control Head

3.1 Pre-installation Planning

Before beginning the installation of the Glendinning Complete Control System, proper consideration and pre-planning should be given to several very important parts of the control system. Proper planning of the installation will help to insure that the Complete Control system will operate correctly and within specification. Failing to properly plan out the installation may decrease the reliability of the system. The following are the most important things to consider in planning. Close attention should be given to these issues:

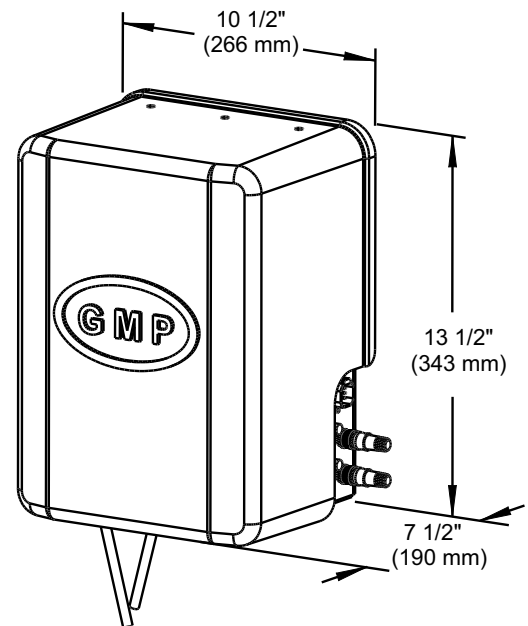
● Smart Actuator Location

Operational Clearances —The primary factor in choosing a location for the actuators is finding a location that results in the shortest, most direct path for the push-pull cable that connects the actuator(s) to the transmission and/or engine governor. In general, for engines where the control cable travels aft from the engine governor / throttle lever, the throttle actuator will be mounted in the aft section of the engine room. Conversely, for engines where the control cable heads forward from the engine governor lever, the actuator will be mounted toward the forward end of the engine room. The Smart Actuator(s) should NOT be mounted on the engine. In general, the length of the control cable from the actuator(s) to the transmission and engine governor should not be greater than 10 feet and 180 total degrees of bend. (Longer lengths may be used after review and approval of the physical layout of the product installation by Glendinning Marine Products).

One reason why a short cable to the engine governor is critical has to do with engine synchronization. In order to accurately synchronize one engine to the other, it is necessary to position the governor with an accuracy of less than five thousandths (0.005") of an inch. Any unnecessary bend in the control cable to the governor lever, or using a cable that is longer than necessary, will result in lost motion between the actuator and engine, causing a reduction in synchronization accuracy.

Environmental conditions —The Smart Actuator(s) should be mounted in an area that is relatively dry and cool. Although the electronic components are reasonably well-sealed from moisture, the product enclosure is not designed for constant, direct contact with water. Since the longevity of electronic components is reduced in high temperature environments it is best to find an area of the engine compartment that is not exposed to temperature extremes. The Smart Actuator(s) has been designed for installation in the engine compartment, and should be mounted where there is some air movement or ventilation.

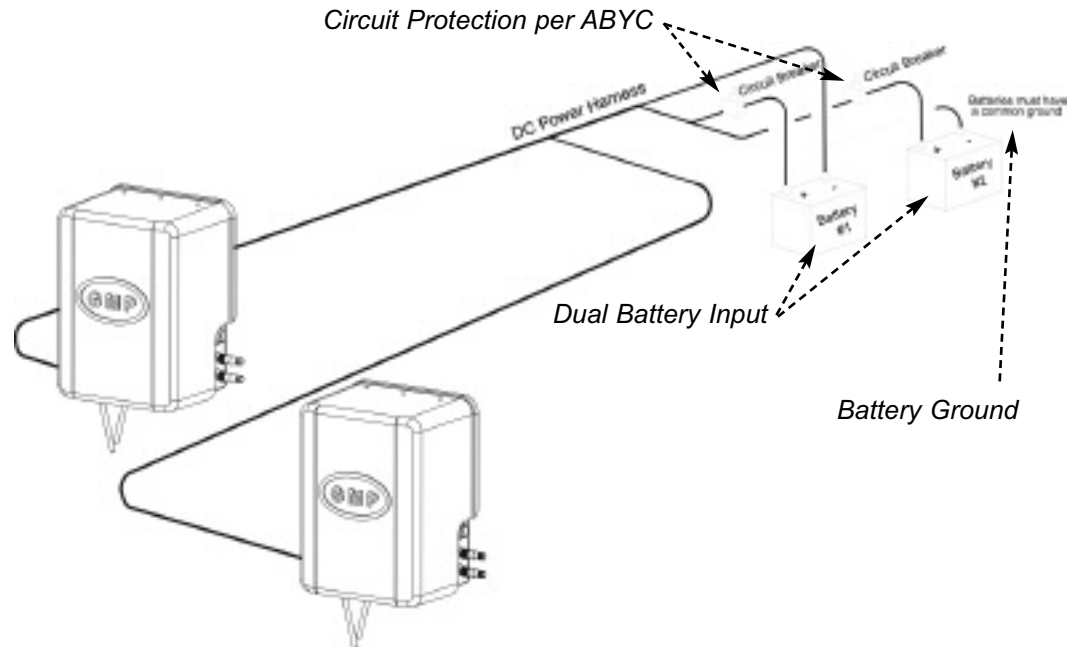
Accessibility — During system calibration or troubleshooting, it will be necessary for the installer or repair technician to have access to the connection points of the Smart Actuator(s). In view of this, the Smart Actuator should be mounted in a relatively accessible area.



● **Power Supply / Enable Switch**

In the installation of any electronic device, the source of power is one of the most important factors to consider during the installation. The Complete Control System has a unique and very reliable power supply system which, if the system is properly installed, greatly improves the overall reliability of the engine control system.

Dual Battery Input—The Smart Actuator(s) provide for the connection of two independent sources of DC power. During normal operation, the Smart Actuator(s) will draw power from both power sources. In a typical boat, the DC power distribution system is designed to take power from a single battery source and then distribute it to the various equipment that require power. Although the Smart Actuator(s) can be powered off the DC distribution panel, this is NOT RECOMMENDED because it is not able to provide for the supply of power from 2 independent



sources to any single device. In other boats, several batteries are arranged in parallel. Obviously, these batteries are not independent—that is, the voltage observed at one battery terminal will be the same at the other battery terminal. It is important that each battery source be completely independent of the other.

Power Source to Smart Actuator(s) Must be Uninterrupted—It cannot be overemphasized that providing a secure, uninterrupted source of power to the Smart Actuator is vitally important to the reliable operation of the control system. For this reason, it is best that the power be drawn as close as possible to the battery positive terminal, without having various components which may interrupt the flow of current to the control system.

Circuit Protection / Enable Switch—Per the ABYC guidelines, some type of current protection—circuit breaker or fuse—must be installed within 7 inches (17cm) of the connection to the source of power. It is very important to understand that circuit protection is installed for the protection of the wire, not the Smart Actuator. The Smart Actuator has its own internal current protection and does not need any external fuse. However, the wire which connects the Smart Actuator to the boat power must be protected in case of chafing or other damage. In order to not limit power to the system during normal operation, a minimum 15 amp fuse or circuit breaker must be installed (if a 30 amp fuse or circuit breaker are used, then it is necessary that 10 AWG wire, or larger, is used to connect the Smart Actuator to its power source). Since the fuse or circuit breaker is physically located in the engine compartment, it would be extremely inconvenient to require the boat operator to have to go to the engine compartment to start-up the Complete Control system each time the boat operator wishes to use the boat. For this reason, Glendinning has allowed for the installation of an enable switch which allows the boat operator to remotely turn ON or OFF the Complete Control system from the helm station. When the enable switch is used, the Smart Actuator circuit protection is typically left in the ON position. The enable switch only requires a small (2 conductor, 18 gauge) wire to be run from the engine compartment to the helm station. **DO NOT APPLY POWER TO THE ENABLE SWITCH**—The purpose of the enable switch is only to open or close the circuit which allows power to be applied to the control system.

Battery Ground—The dual battery system requires that the battery positive terminals be at roughly the same voltage. In order for the battery positive terminals to be at the same voltage, it is necessary that the negative terminals of the batteries be connected at some common point. This is normal marine electrical practice and is specified in the ABYC guidelines. Prior to the final electrical hookup of the Complete Control system, the installer should verify that the battery ground termi-

nals are connected at some common point.

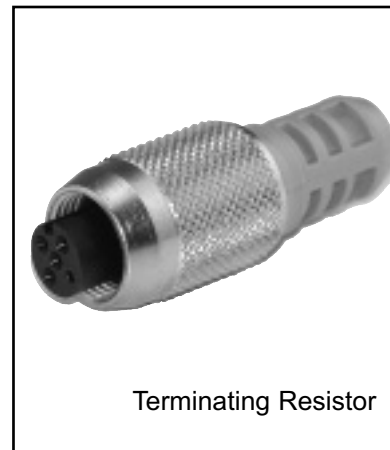
● **Station Communications Cable / Network Installations**

The Complete Control System utilizes CANbus technology to communicate between the Smart Actuator and the Control Station(s). Simply put, the CAN(Controller Area Network)bus network consists of a series of devices connected by a single wire routed throughout the boat. Station communication connects each system component sequentially which minimizes cable runs and lengths. At each end of the bus network a CANbus terminator (terminating resistor) must be connected in order for the system to perform correctly.

Station Communication Cable Routing—When routing Station Cables it is advisable to inspect the route and make sure surfaces are free of any sharp edges or burrs which could nick the cable and compromise the reliability of the system.

Connectors are pre-terminated at the factory and should NEVER be forced into their proper receptacle. Make sure that the connector is properly aligned prior to insertion into the receptacle. If the connector is properly aligned, only a small amount of force will be necessary to insert the connector into the Smart Actuator or Control Head. Failure to properly align connector may damage the pins and cause the system to fail.

Connectors are one of the most important parts of the Complete Control system. Keep connectors covered and clean during installation. Most problems occur due to bad connections.



Terminating Resistor

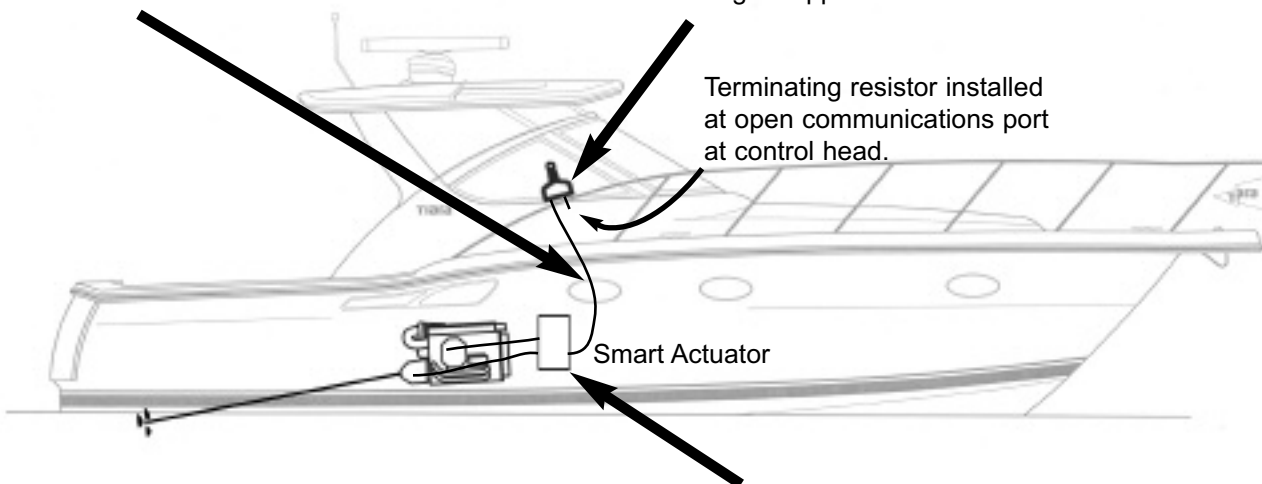
● **EEC3 System Layouts**

Single Station Layout

Single cable connects control head to control processor.

Standard CP Control Head must be installed for single engine applications

Terminating resistor installed at open communications port at control head.



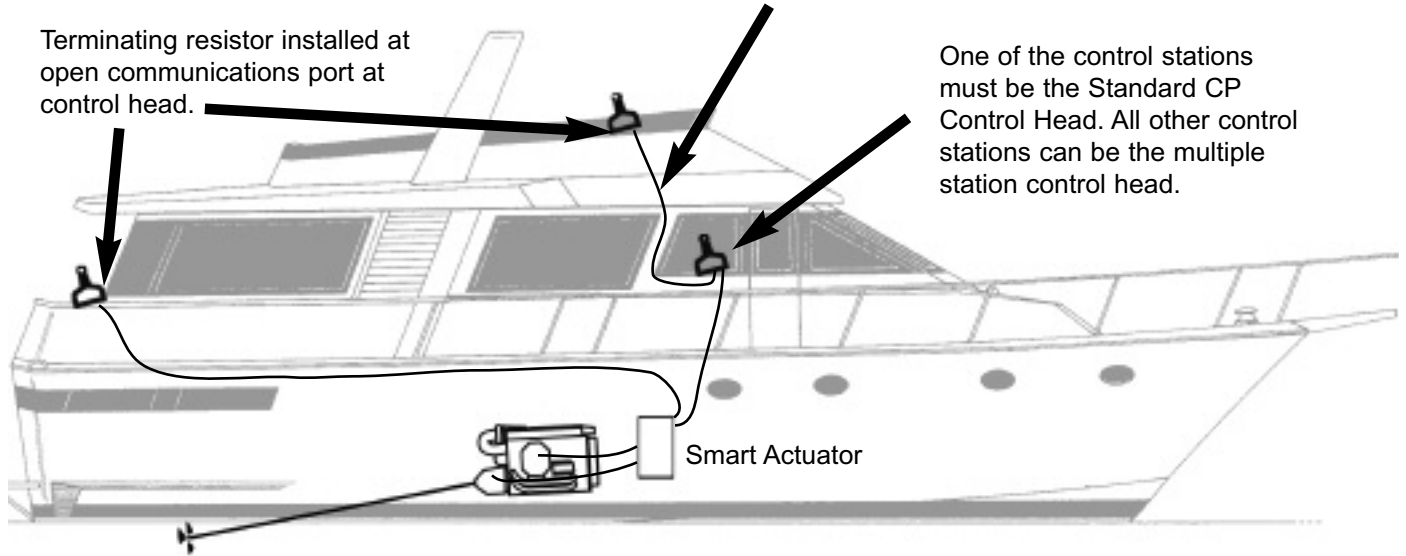
Terminating resistor installed at open communications port at Smart Actuator.

Multiple Station Layout

Single cable connects control head to control head (“daisy chained”).

Terminating resistor installed at open communications port at control head.

One of the control stations must be the Standard CP Control Head. All other control stations can be the multiple station control head.



3.2 Engine Compartment — Mount the Smart Actuator

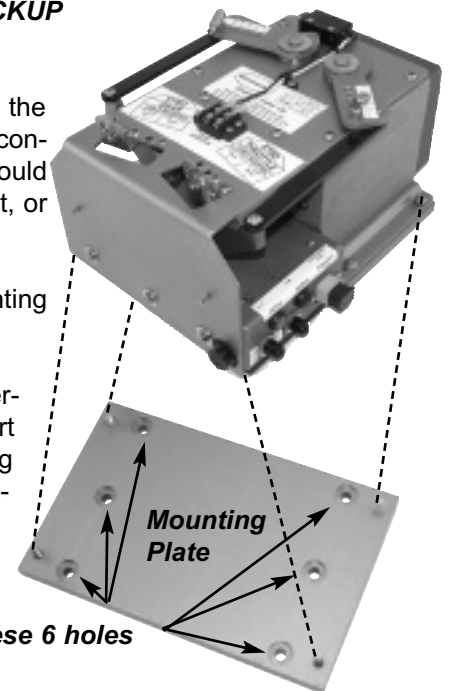
REFER TO SECTION 7.3 FOR INSTRUCTIONS IF USING A MECHANICAL BACKUP ACTUATOR.

The Smart Actuator(s) can be mounted anywhere in the engine room providing that the Actuator(s) is reasonably accessible so that inspection and/or repairs to the unit, and connection of throttle and/or gear control cables may be performed. The Smart Actuator should NOT be installed in adverse locations subject to saltwater exposure or excessive heat, or vibration — DO NOT MOUNT ON THE ENGINE.

The installation process consists of two steps: (1) installing the Smart Actuator Mounting Plate and (2) connecting the Smart Actuator to the mounting plate.

STEP 1: Once the proper location for the mounting of the Smart Actuator has been determined (see Pre-Installation Planning section 3.1 for guidelines), mount the Smart Actuator Mounting Plate using (6) 1/4" (7mm) machine bolts or lag screws. If using lag screws, screw length should be no less than 1-1/2" (38mm). If using machine bolts, lockwashers or locknuts MUST be used.

STEP 2: Attach the Smart Actuator to the mounting plate using (4) 1/4" - 20 nuts with lockwashers.



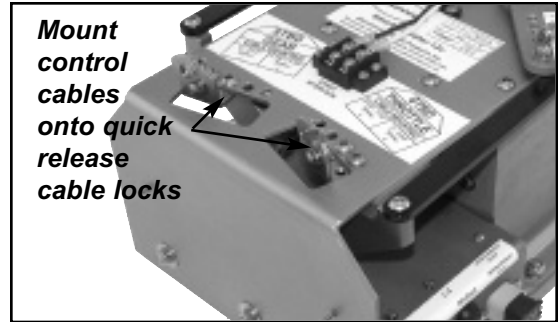
Mount Plate using these 6 holes

3.3 Engine Compartment — Control Cable Connections

REFER TO SECTION 7.3 FOR MECHANICAL BACKUP CONTROL CABLE CONNECTION INSTRUCTIONS.

A. Using the control cable swing clamp, mount the throttle / gear / troll lever control cables in their respective locations on the engine and transmission. Mount cables - do not connect the cable ends to the control levers at this time (NOTE: Although 43c cables can be installed with our system, we recommend premium grade, Type 33C control cables as the best cable choice).

B. Install swivel ball joints on the end of each control cable, ensuring that you have at least 1/2" (13 mm) of thread engagement. Do not tighten the cable jam nuts yet.



NOTE

In some cases, sufficient over-travel will not be able to be obtained even with adjustment of the cable clamp holder. This is caused by the connection point on the engine or transmission lever (normally called the pivot pin) being too far away from the shaft that the lever is connected to. In these cases, the pivot pin will have to be moved closer to the shaft (the "fulcrum point") in order to shorten the pivot pin travel. This will give you the correct over-travel required. The recommended length of travel of the control lever pivot pin should be approximately 2-1/2" to 2-3/4".

C. Compare the travel of each control cable to its associated lever at the transmission and engine. Ensure that each control cable has "over-travel" or that the cable is able to travel farther than the lever that it will be attached to. Check this for both ends of travel. If the control cable will not "over-travel" in both directions, adjustments will have to be made:

- ⊙ If 1/4" or less adjustment is required, the terminal eye on the end of the cable may be screwed on or off the cable end. Ball joint thread engagement on the control cable end must never be less than 1/4".
- ⊙ If more than 1/4" inch adjustment is necessary to achieve correct over-travel, the cable clamp position on the engine or transmission will have to be moved.

Once correct control cable over-travel is verified, connect the terminal eye of each control cable to the engine governor / throttle and transmission lever and install the pivot pin cotter pins or clips. Tighten the control cable terminal eye jam nuts.

D. After the control cable terminal eyes are attached to the control levers on the engine governor and transmission, measure the amount of travel for each control cable. Do this measurement at the actuator end of the control cable. (This is the distance that the cable will travel when the engine or transmission control lever is moved from one mechanical stop to the other. Record the information below - this information is needed in order to determine the correct cable connection on the Actuator coupler plates.

PORT ENGINE		STARBOARD ENGINE	
CONTROL CABLE	LENGTH OF TRAVEL	CONTROL CABLE	LENGTH OF TRAVEL
Throttle		Throttle	
Gear		Gear	
Troll Valve		Troll Valve	

E. Mount the engine / transmission control cables to the proper control cable mounting location on the actuator. There are two possible mounting locations on the actuator for the control cables depending on the length of control cable travel - the distance measured in paragraph D. above. For control cable travel between 1-1/2" and 2-3/16", mount the control cable in the SHORT Travel Mounting location. For control cable travel between 2-1/4" and 3-1/8", mount the control cable in the LONG Travel Mounting location. (See the drawing on page 24 for clarification).

F. Select the correct Actuator cable lever connection hole to be used, depending on length of control cable travel.

G. Move the ball joint ball pin on Actuator plate to the correct actuator travel.

H. Adjust control cable terminal prior to attaching to Actuator coupler plate. Leave the control cables disconnected until you are ready to proceed with Smart Actuator Calibration (Section 4.0).

3.4 Engine Compartment — Electrical Connections

A. Battery Power Supply Connections to the Actuator(s)

In the installation of any electronic device, the source of power is one of the most important factors to consider during the installation. The Glendinning Electronic Engine Control has a unique and very reliable power supply system which, if the system is properly installed, greatly improves the overall reliability of the engine control system. *NOTE: The EEC can use 12 or 24V DC power, however, see the specific wiring diagram (see sec 7.1, or supplied by GMP technician) for the correct power to use. In some installations it is required to use 24V DC instead of 12V DC.*

The Glendinning EEC system is equipped with a sophisticated power management system that allows it to receive power from two (2) independent batteries (normally the port and starboard engine start batteries). In normal operation, the EEC will receive power from both battery sources, taking power from each battery proportionate to the voltage from level available. In the event of loss or reduction of voltage from one battery source, such as during engine start, the EEC system will continue to function normally by receiving power from the other battery with normal voltage.

1) Connect the Smart Actuator DC Power Harness (supplied) to two (2) independent battery sources, (normally the port and starboard engine start batteries). On the positive side of these two runs, install a 15amp circuit breaker near each battery or power source (follow ABYC standards which require a circuit protection device within 7" of the wire connection to the power source — *NOTE: If the total wire run is longer than 15 feet from the battery to the Control Processor, install an approved junction box that the DC Power Cable may be connected to).*

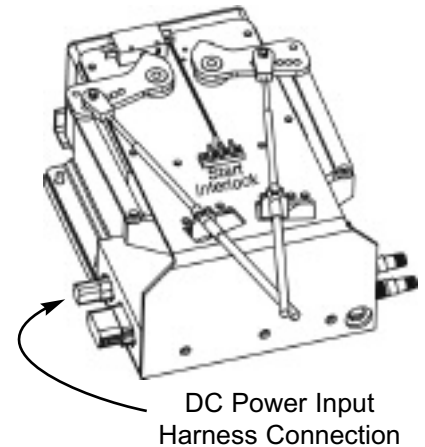
2) Make sure that the breakers are in the OFF position and then connect the "DC Power" to the Control Processor where indicated (see Sec. 7.1-Wiring Diagrams).

B. Remote Enable Switch

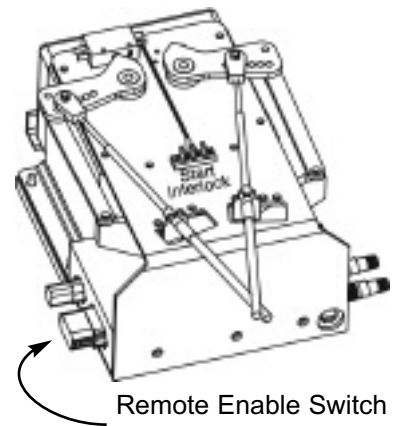
While the boat is tied up at the dock and not in use, it is recommended that the EEC system be turned off. Since power is normally supplied directly to the Smart Actuator from power sources in the engine room, turning power ON and OFF in the engine room may be difficult to do each time the system is started up. For this reason, a remote enable switch is available for use with the EEC control system. This enable switch allows power to the system to be turned ON or OFF at the Main station.

The EEC System Enable Switch is installed as follows:

1. Make sure the circuit breakers that control the power to the Control Processor are turned off before starting this installation.
2. Install a Single Pole, Single Throw (SPST) switch in the instrument panel. GMP has a switch/nameplate assembly designed for this purpose. The switch features a locking rocker that eliminates inadvertent activation of the switch. *NOTE: If installing a switch other than GMP's, locate the switch in an area where it will not be inadvertently turned OFF during operation.*



DC Power Input
Harness Connection



Remote Enable Switch
Harness Connection

3. Connect switch to harness provided.

NOTE: Do not connect an indicator light to the remote enable switch connections.

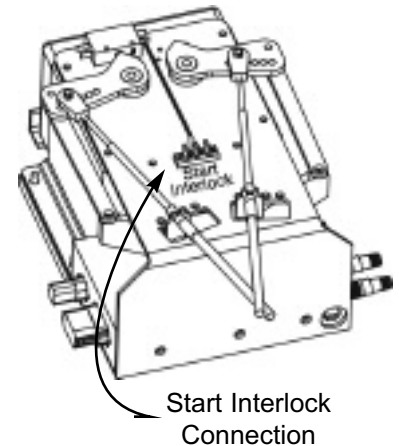
NOTE: A "jumper" can be installed in the place of wires on the connector at Smart Actuator. Power may then be turned OFF and ON by using the 15amp breakers installed at battery input.

C. Start Interlock

The Smart Actuator system includes a "start interlock" safety feature — this feature verifies that the transmission control lever is in Neutral prior to starting the engines. In order to utilize this product feature, the signal wire from the helm station start switch to the engine starter solenoid must be intercepted and run through the control switches within the Control Processor.

To install the Start Interlock system:

- 1) Run a wire to the terminal strip on the front of the actuator marked "Start Interlock".
- 2) Route these wires to the engine distribution box and connect using appropriate connectors (see Sec. 9.1-Wiring diagrams).



D. Tachometer Sender Inputs

The purpose of the tachometer sender is to provide RPM information to the EEC system. This information is used by the System during engine synchronization. Installation of the tachometer senders is relatively straightforward. The following points should be considered:

1) Only tachometer senders that are supplied by GMP are to be used with the EEC system.

2) On engines equipped with mechanical tachometer outlets, such as Detroit Diesel, Caterpillar 3208, MAN, etc. the tach senders may be directly connected to the tachometer outlet on the engine. The tach senders that are supplied by GMP are "in-line" senders; that is, they may be installed between the engine tachometer connection and any other tachometer senders or tachometer drive cables that are attached to that tachometer connection.

3) On engines that are not equipped with a tach sender outlet, such as Volvo Diesel or any gasoline engine, a mechanical tachometer adapter will have to be used.

4) The tach senders must be driven at a speed that corresponds to 1/2 engine speed. This is normal on most engines that have mechanical tachometer outlets or that use a mechanical drive adapter. On some engines, it may be possible to drive the tach sender at 1:1 or even twice engine speed. If this is done, the Engine Processor will be damaged due to excessive voltage output from the tach sender. To check for excessive tach sender speed, set your meter on frequency or hertz, verify that at full open the frequency is no larger than 5000 hz. (If you cannot check frequency, check the voltage from the tach sender while the engine is running at full speed. No more than 18 VAC should be present at the tachometer sender terminals.)



Wiring the Tachometer Senders to the Smart Actuator:

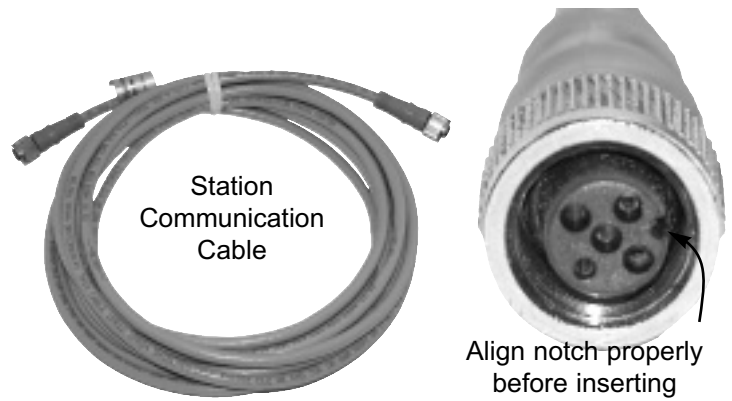
Connect the Black and Black w/ red stripe wires from the Tachometer Sender to the Smart Actuator PORT Harness / Electric Gear Enable Harness / or the Center Engine Harness (see pgs. 48-49, & 52). **DO NOT CONNECT ANYTHING ELSE** to these wires (the other wires, yellow and red, may be used to drive other tachometers and related equipment).

E. Station Communication Cable Connections

Review comments made in *Pre-Installation Planning, paragraph 12*, for determining proper routing of cables. Cables are manufactured in 20' increments and are available from 20 - 120 feet.

When routing and connecting station communication cables, BE SURE TO DO THE FOLLOWING:

- Use a terminating resistor at each end of the bus (see diagram pg. 11).
- Align the cables before connecting them to the proper connector on the Control Head and/or Smart Actuator(s).



REMEMBER:

—Connector nut requires 6 turns of the nut to be fully seated, failure to do this will result in inconsistent operation of the system.

—If the connector is properly aligned, only a small amount of force will be necessary to insert the connector into the Control Processor or Control Head. Failure to properly align connector may damage the pins and cause the system to fail.

F. Solenoid Gear Interface Box (optional)

The Solenoid Gear Interface Box communicates information necessary for the control of the Smart Actuator(s) and your boat's solenoid controlled transmissions. The components of the Solenoid Gear Interface Box are:

- DC Power Harness
- Gear Harnesses (Port & Starboard)
- Start Interlock Harness
- Interconnect Harness

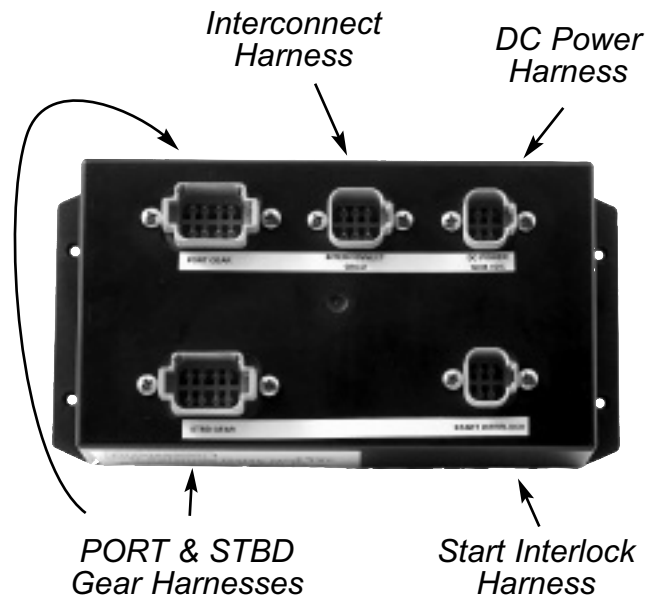
Installation of the Solenoid Gear Interface Box is very easy and requires two main steps. They are:

STEP 1: Mount the Interface Box near the Smart Actuator using (4) screws. An ideal location would be next to the Smart Actuator directly under the control cables as they leave the Actuator.

STEP 2: Connect the various harnesses (see below):

a. **DC Power Harness** — The DC power harness for the Smart Actuator comes equipped with two connectors. One connector plugs into the proper receptacle on the Smart Actuator. The other connector plugs into the appropriate labeled receptacle on the Solenoid Gear Interface Box.

b. **Gear Harnesses** — One end of the the Port and Starboard Gear Harnesses is connected to the Solenoid Gear Interface Box in the properly labeled receptacles. The other end is connected to the appropriate (Port or Starboard) gear solenoid on your engines.



c. **Start Interlock Harness** — The Start Interlock Harness should be connected to the appropriate labelled connector on the Interface Box and the engine starter solenoid.

d. **Interconnect Harness** — Normally 1' long, this cable connects to the 6 position connector on the Smart Actuator and the Solenoid Gear Interface Box.

3.5 Mounting the Control Head

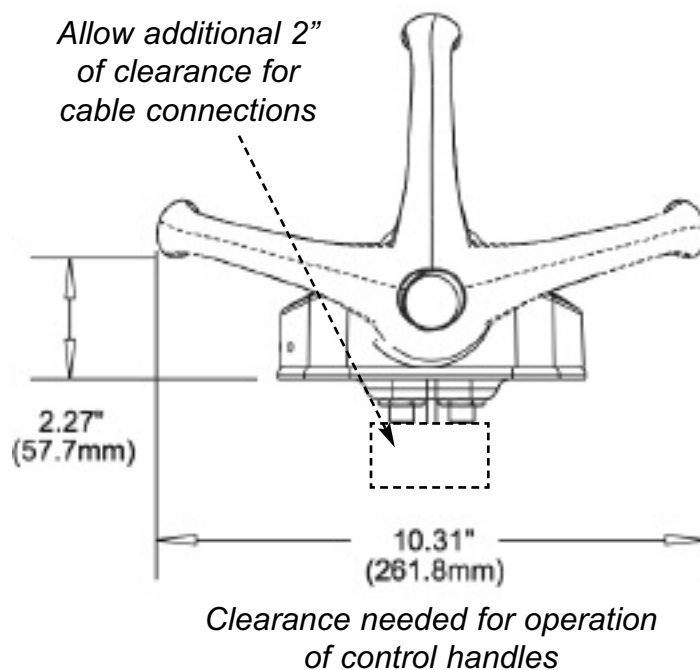
One of the most important factors in selecting control head locations is the ability to control the vessel by allowing FULL movement of the control head handles. The area around the control head should have proper drainage to eliminate standing water. Although the control heads are sealed to withstand damage from exposure to moisture, they are not designed to be submerged.

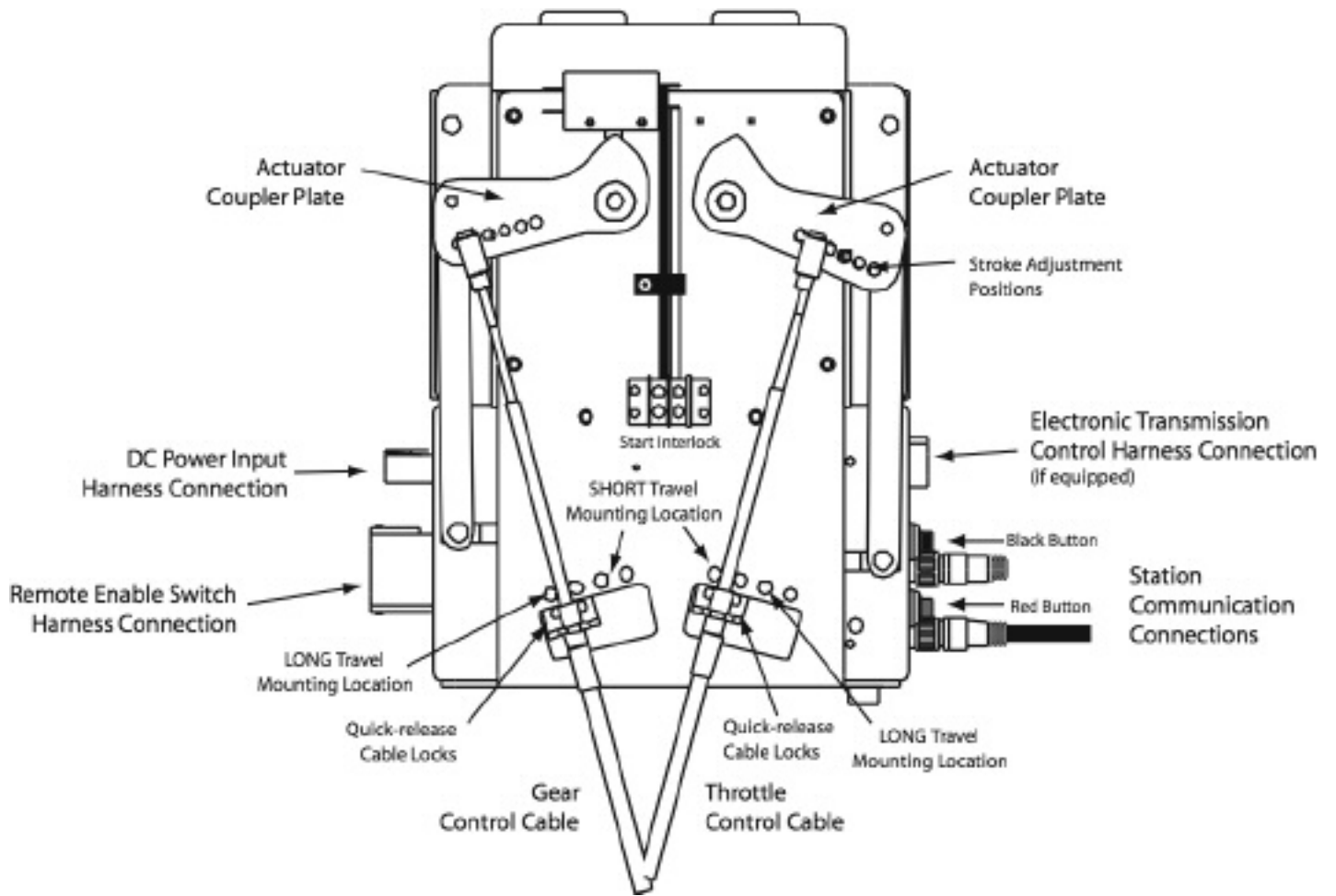
There are two types of control heads available with the Smart Actuator system — they are the Main CP control head and the Multi station control head. Both the main and multi station control heads perform all functions necessary for the control of your boat's propulsion system. The Main CP control head also includes the necessary components built-in for communication between all control stations along the CANbus network and the Smart Actuator(s). For single station applications you will need the Main CP control head. For multiple station applications you are required to have (1) one Main CP control head and the other control heads may be the multi station control heads.

STEP 1: Mark the location for the Control Head using the template provided (see Sec. 7.2 -Dimensional Drawings / Cutout Templates). Cut the 3-3/8" x 4-7/8" hole.

STEP 2: Place the Control Head assembly into the cutout. The Control Head clamps, which hold the control head against the console, have a break off point indicated by a perforation. For consoles 1/4" to 1" thickness, use bracket as supplied. For 3/4" to 1-5/8" thickness, break off clamp at 3/4" break off point.

STEP 3: Install Control Head clamps and tighten wing nuts provided. Make sure Control Head is firmly mounted to console.






4.0 Smart Actuator Calibration

The Smart Actuator Calibration Mode allows you to change settings for the Smart Actuator so that it will perform correctly with the boat's propulsion system. The Smart Actuator Calibration Mode is in two sections:

Section 6.1 — Calibrating the Actuator Endpoints & Cable Directions

Section 6.2 — Setting the Cable Direction only (if endpoints have already been calibrated and only cable direction needs changing).



**DO NOT CONNECT PUSH - PULL CABLES TO THE ACTUATORS
PRIOR TO CALIBRATING ACTUATOR ENDPOINTS AND CABLE DIRECTION!**

The Smart Actuator receives electronic impulses from the control head which moves the actuator plates into a position where the associated engine's gear or throttle control lever has reached its mechanical stop position (endpoints) — see Figure 1. Calibration of the Smart Actuator endpoints is necessary to ensure that the engine achieves idle speed or full throttle when moved by the Smart Actuator.

It is important to find the proper balance between the control cable position being "too loose" and not reaching its endpoint position (and therefore the engine not achieving idle speed or full throttle), and the cable being set up "too tight" and constantly operating in a compressed or stretched condition when moving to its endpoint of travel. Calibrating the Smart Actuator(s) with this proper balance will yield trouble-free operation of your engine's propulsion system.

To calibrate the actuator endpoints it will be necessary for you to follow the instructions in the chart (Section 4.1) on the following pages.

Prior to configuration of the Smart Actuator, it is vital to determine the actual direction of travel of the control cables that connect to the engine governor and transmission control levers. Circle the appropriate direction on the charts below:


TRANSMISSION GEAR LEVER MOVEMENT

PORT ENGINE		STARBOARD ENGINE	
To engage	PUSH	To engage	PUSH
AHEAD	OR	AHEAD	OR
gear:	PULL	gear:	PULL


ENGINE GOVERNOR LEVER MOVEMENT

PORT ENGINE		STARBOARD ENGINE	
To	PUSH	To	PUSH
INCREASE	OR	INCREASE	OR
engine	PULL	engine	PULL
speed:		speed:	

To continue with calibrating Actuator Endpoints and setting Cable Direction, follow the instructions on the following page.



**CAUTION: KEEP HANDS AWAY FROM MOVING COMPONENTS OF
ACTUATORS WHEN CALIBRATING ENDPOINTS!**



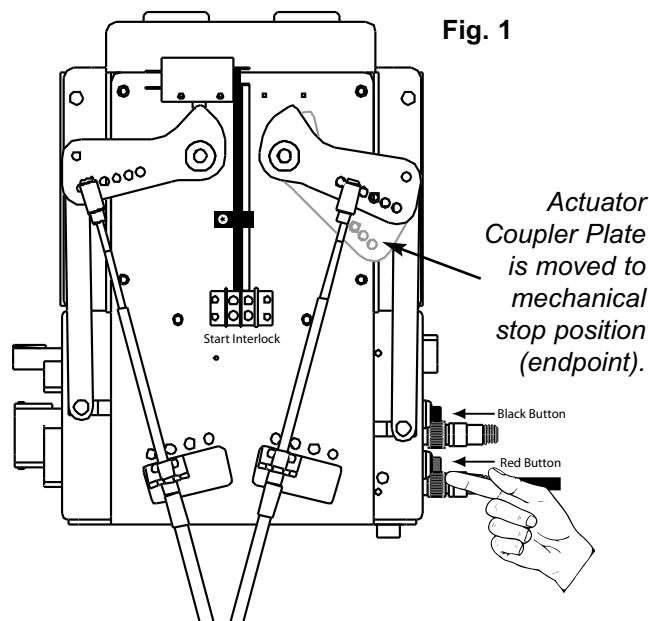
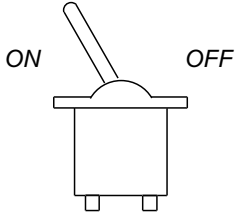
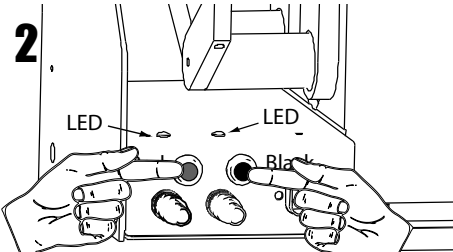
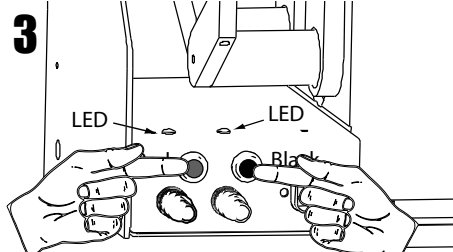
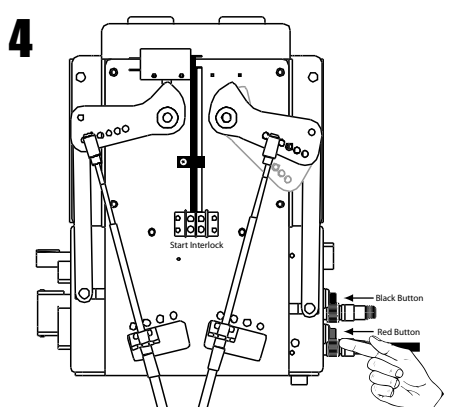
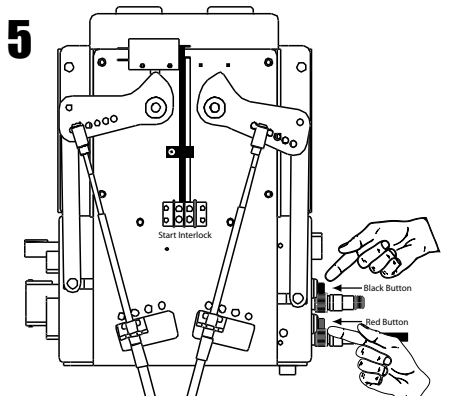
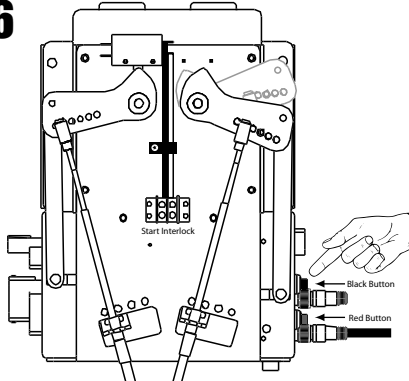
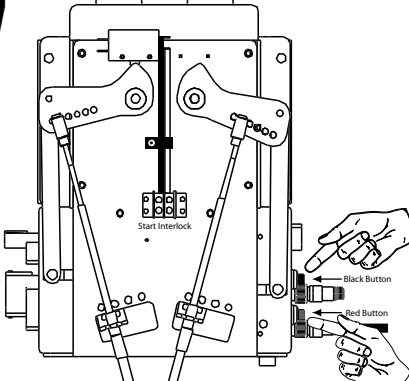
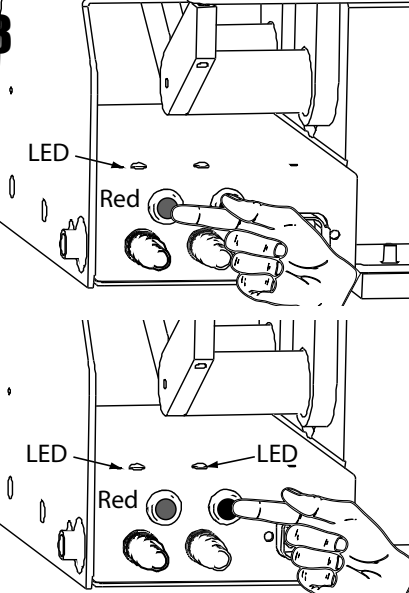
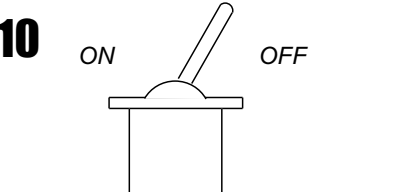


Fig. 1

4.1 To Calibrate the Actuator(s) Endpoints & set Cable Direction, follow these steps:

<p>1</p> 	<p>ACTION</p>	<p>RESULT</p>
<p>2</p> 	<p>Press & Release both the RED & BLACK buttons on the Smart Actuator simultaneously 3 times</p>	<p>Both LEDs above the RED and BLACK buttons will flash to indicate that you have entered Smart Actuator Configuration Mode</p>
<p>If calibration of the Throttle Actuator is desired, continue with the steps below. If calibration of ONLY the Gear Actuator is desired (but NOT Throttle Actuator), then PRESS & RELEASE the RED button 1 time BEFORE continuing with the steps below.</p>		
<p>3</p> 	<p>Press & Release both the RED & BLACK buttons simultaneously on the Smart Actuator 1 time</p>	<p>Both LEDs above the RED and BLACK buttons will go OUT — this indicates that you are ready to calibrate the Actuator endpoints</p>
<p>4</p> 	<p>Press & Release the RED button repeatedly to EXTEND the actuator piston to the desired position — if you extend the piston too far you may PRESS & RELEASE the BLACK button to RETRACT to desired position</p>	<p>You may also Press & HOLD down the RED button to extend the actuator piston in larger increments until the desired position is achieved. Be careful to RELEASE button when endpoint is achieved!</p>
<p>5</p> 	<p>Press & Release BOTH the RED & BLACK buttons simultaneously 1 time to confirm actuator piston extended position</p>	<p>The LED above the RED button will illuminate to indicate that extended piston position is saved in memory.</p>

<p>6</p> 	<p>ACTION</p> <p>Press & Release the BLACK button repeatedly to RETRACT the actuator piston to the desired position — if you extend the piston too far you may PRESS & RELEASE the RED button to EXTEND to desired position</p>	<p>RESULT</p> <p>You may also Press & HOLD down the BLACK button to retract the actuator piston in larger increments until the desired position is achieved.</p> <p>Be careful to RELEASE button when endpoint is achieved!</p>											
<p>7</p> 	<p>Press & Release BOTH the RED & BLACK buttons simultaneously 1 time to confirm actuator piston retracted position</p>	<p>BOTH LEDs above the RED & BLACK buttons will illuminate to indicate that retracted piston position is saved in memory.</p>											
<p>8</p> 	<p>IMPORTANT</p> <p>Press the RED or the BLACK button to confirm correct travel direction for actuator piston:</p> <p>For PUSH to OPEN / AHEAD — press & release the RED button</p> <p>For PULL to OPEN / AHEAD — press & release the BLACK button</p>	<table border="1"> <thead> <tr> <th></th> <th>LEDs ON</th> <th>TRAVEL DIRECTION</th> </tr> </thead> <tbody> <tr> <td>1</td> <td>LED 1 (above RED button)</td> <td>PUSH direction</td> </tr> <tr> <td>2</td> <td>LED 2 (above BLK button)</td> <td>PULL direction</td> </tr> </tbody> </table>		LEDs ON	TRAVEL DIRECTION	1	LED 1 (above RED button)	PUSH direction	2	LED 2 (above BLK button)	PULL direction		
	LEDs ON	TRAVEL DIRECTION											
1	LED 1 (above RED button)	PUSH direction											
2	LED 2 (above BLK button)	PULL direction											
<p>If it becomes necessary to change the travel direction that has been entered during this procedure, refer to Sec. 7.7.4 for directions on how to ONLY set the cable travel direction for the Smart Actuator without having to go through this entire calibration process.</p>													
<p>9 REPEAT steps 3 — 8 for the Gear Actuator piston. NOTE: After completing Endpoint Calibration of the Throttle Actuator, <u>if endpoint calibration of the Gear Actuator is not required</u>, you can proceed to step 10 (turn OFF power and restart).</p>													
<p>10</p> 	<p>Turn OFF power to the Smart Actuators and RESTART</p>	<p>You have successfully completed the calibration of the Smart Actuator(s). Proceed to Section 4.2 for Calibration Verification.</p>											

4.2 Calibration Verification

Upon completion of the Calibration procedure, it is advisable that the operation of the EEC system be inspected to verify that each engine throttle and transmission lever is being properly moved in the correct direction and through the full range of travel. **Failure to do this can cause gear / transmission failure if the gear control lever is not moved into its correct position.**



The following points should be kept in mind when verifying actuator position and operation:

Direction of travel - The location of engine idle and full throttle, gear ahead and astern, and troll valve lock-up / slip should be considered to ensure that the actuator is moving the engine and gear controls in the appropriate direction.

Actuator endpoint - The actuator should move its associated control lever to the mechanical stop without placing undue strain on the control cable or control lever.

Control lever detent position - When position the gear lever or trolling valve lever, it may be helpful to disconnect the push-pull cable from the lever and move the control lever independently from the system.

A suggested verification procedure follows:

1. Take control at any station that is convenient for good communication between the engine room and helm station.
2. With the station control levers (port and starboard) in the **neutral position**, verify the following for both engines and transmissions:
 - Engine governor - Idle position (mechanical stop)
 - Gear control lever - Neutral position
 - Trolling valve (if installed) - Lockup position (troll valve closed)
3. Move the station control levers (port and starboard) to the **ahead detent position**. Verify that both gear control levers have moved to the ahead position **and that the control cable is not binding**.
4. Move the station control lever (port and starboard) to the **astern detent position**. Verify that both transmission levers have moved to the astern position **and that the control cable is not binding**.
5. Move the station control lever (port and starboard) to the **full ahead and full astern positions**. Verify that both engine governors are at the full throttle (mechanical stop) position **and that the control cable is not binding**.
6. Move the station control lever (port and starboard) to the **neutral position**. Verify that both engine governors are at the idle (mechanical stop) position **and that the control cable is not binding**.
7. (Troll valve equipped boats only) - Move the station control lever (port and starboard) to the **neutral position**. Press and release the troll switch on the control. Troll switch light will illuminate indicating that troll mode is energized. Verify that both troll actuators have moved to troll valve open position **and that the control cable is not binding**.
8. (Troll valve equipped boats only) - Move the station control lever (port and starboard) to the **full throttle position**. Verify that both troll actuators have moved toward lockup position, but have not moved into the detented lock-up position **and that the control cable is not binding**.
9. (Troll valve equipped boats only) - Move the station control lever (port and starboard) to the **neutral position**. Press and release the troll switch on the control. Troll switch light will go out indicating that troll mode is off and that normal gear / throttle operation is available.. Verify that both troll actuators have returned to the lockup position **and that the control cable is not binding**.

After performing the Calibration Verification, if you find that one actuator position needs to be changed, refer to the beginning of the Calibration section and follow the instructions to re-calibrate the actuator endpoints.

This completes the calibration procedure. The electronic engine control system is now fully operational and ready for use.

5.0 System Test & Checkout

System test and checkout consists of 2 steps:

- 1) **Component installation checks** — verify that the components appear to be correctly mounted and installed.
- 2) **Operational tests** — make sure the system is operating correctly.

5.1 Component Installation Checks

A. Actuators

1.1	Verify Actuator(s) is securely fastened to boat structure.
1.2	<p>Verify electrical power connections:</p> <p><i>Battery Negatives</i>—Negatives from both batteries should be connected (not at Control Processor. It is vital that there be zero voltage potential between battery negative terminals. Battery negative terminals should be connected to Bonding system also.</p> <p><i>Negative Lead</i>—Negative wire from EEC system is connected to single battery negative.</p> <p><i>Positive Leads</i>—Power should be connected from Battery positive terminal or disconnect switch (battery side of switch) to CP via 10 amp fuse / circuit breaker. Check that all battery connections are tight. Verify that Bonding Wire is properly connected to Bonding studs (see sec. 3.6).</p>
1.3	Verify that all connectors are properly inserted into their receptacles (Station Cables, Transmission Cables, Throttle Cables, and Troll Cables). DO NOT FORCE connectors into receptacles!. All wires should be secured with tie-wraps along route.

B. Control Head(s)

2.1	Verify Control Head(s) are securely fastened to boat structure.
2.2	Verify that Control Handles have an unobstructed freedom of movement (full ahead and full reverse).
2.3	Return all handles to NEUTRAL.

5.2 Operational Checks

A. General Functions

NOTE: While performing system checks, verify that the “Check System” LED stays OFF. If it comes ON, the system is in Alarm Mode (see Sec. 2.9) and alarm condition must be checked and corrected before proceeding.

B. Start Interlock

3.1	Turn System ON (see sec. 2.1).
3.2	Verify at the main station various functions: Warm up, Slow, Troll, Sync.
3.3	Transfer control to other stations (see sec. 2.7) and verify proper operation of functions at each station.

C. Power Inputs

4.1	Move Starboard Control Handle out of NEUTRAL position. Attempt to start engine. <i>(NOTE: Be prepared to immediately shutdown engine if start interlock has been wired incorrectly!)</i>
4.2	Engine should NOT start; if it does, start interlock has not been wired correctly. Fix wiring and re-check.
4.3	Move Starbord Control Handle back to NEUTRAL position. After handle is moved to NEUTRAL position, then try to start engine. Engine should start.
4.4	Perform same check for Port engine.

D. Engine Room Checks

5.1	To verify separate power inputs, turn ON individual breakers one at a time and verify that DC power (12 or 24 VDC) is supplied to the Control Processor.
-----	--

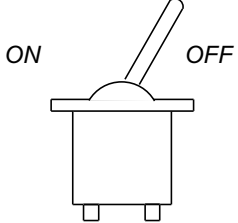
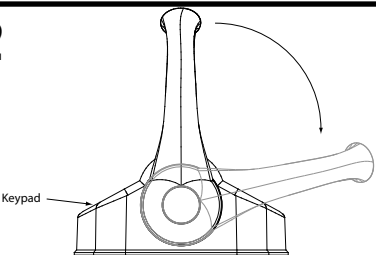
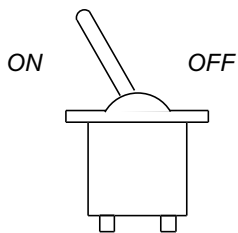

E. Trolling Valves (if equipped)

6.1	Gear Operation — Verify that transmission solenoid valves are turning ON and OFF as you move Control Handles into and out of gear. Make sure that transmission shifts into appropriate direction — pushing handle forward causes forward boat motion, etc.
-----	--

6.0 Enter Handle Troubleshoot Mode

To review the stored alarm codes you must first enter “Handle Troubleshoot Mode.” To do this you must use the main station control head and follow the 4 simple steps below:



To Enter Handle Troubleshoot Mode, follow these steps:

1	ACTION	RESULT
	<p>Turn power to control system OFF</p>	<p>Check to see that the control head keypad LEDs are NOT illuminated. This is a visual indication that the system has been turned OFF.</p>
	<p>Move handles to their FULL AHEAD positions</p>	<p>N/A</p>
	<p>Turn power to control system ON</p>	<p>When the system has been turned on the TAKE LED will blink slowly and a beeping sound will emit from the control head keypad.</p>
	<p>PRESS & RELEASE the two center buttons on the keypad simultaneously 3 times</p>	<p>After pressing the two buttons, the keypad's 4 LEDs will now begin to alternate between slow flashing and fast flashing every 4 seconds.</p>

6.1 Retrieve alarm count & alarm codes

The control head keypad LEDs will alternate between **slow blinking** and **fast blinking**, every 4 seconds, to indicate the alarm count and the alarm codes. The system stores in memory the 16 most recent alarm codes beginning with the latest.


To Retrieve Alarm Count & Alarm Codes, follow these steps:

1	ACTION	RESULT
	<p>Record the sequence of flashing LEDs in the space provided on the chart on page 34</p>	<p>Using the chart on page 34, determine the number of alarm counts.</p>
	<p>PRESS & RELEASE the SYNC button to cycle through the 16 most recent alarm codes</p>	<p>Record the sequence of flashing LEDs on the chart on page 35. Determine the alarm code by using the chart on page 36 and fill in the appropriate space on the chart.</p>

6.2 Deleting Alarm Codes and Resetting Alarm Count to Zero

While in Handle Troubleshoot Mode you can delete the 16 most recent alarm codes and reset the alarm count to zero at any time after viewing one or more alarm codes. Deleting alarm codes and resetting alarm count will minimize confusion for future troubleshooting. Follow the step below:

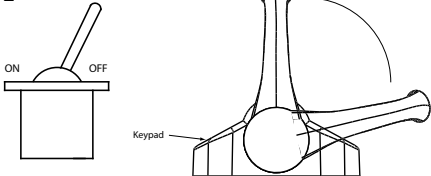
To Delete Alarm Codes & Reset Alarm Count to Zero, follow this step:

1	ACTION	RESULT
	<p>PRESS & RELEASE the SYNC & WARM buttons simultaneously</p>	<p>All LEDs will flash to indicate that alarm codes and alarm count have been reset.</p> <p>You may perform this procedure at any time after retrieving alarm information.</p>

6.3 Exiting Handle Troubleshoot Mode

Once alarm codes have been reviewed and / or deleted, simply turn the system OFF and return the main station control handles to NEUTRAL before restarting system.

To Exit Handle Troubleshoot Mode, follow this step:

1	ACTION	RESULT
	<p>Turn Power OFF and return control head handles to their NEUTRAL positions</p>	<p>You may now restart the system for normal operation.</p>

EXAMPLE

The following describes an actual problem that occurred on a boat which will illustrate the use of our troubleshooting mode.

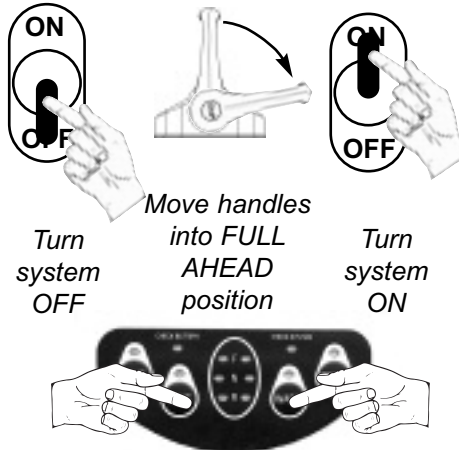
When John turned his system on he noticed that all 4 LEDs on the keypad were flashing and the control head was beeping. He knew this was not normal and wanted to troubleshoot what was wrong.

All LEDs flashing



Beeping sound emitted

John entered the system into "Handle Troubleshoot Mode" by **turning the system OFF**, moving the handles of the main station control **into the FULL AHEAD position**, and **turning the system back ON**. He then pressed the 2 center buttons on the keypad simultaneously 3 times. Now John can easily troubleshoot the problem.



John next noticed that the keypad LEDs began to alternate every 4 seconds between **slow blinking** and **fast blinking**. He recorded the LEDs that were blinking slow and the LEDs that were blinking fast on the chart (see pg. 34). The sequence below showed the system went into alarm a total of 3 times.

Slow blinking



Fast blinking



John **pressed the SYNC button** to reveal the first alarm code. He recorded the sequence of blinking LEDs (pg. 35) and using the alarm code description chart (pg. 36), John determined that the battery voltage at startup was below 9.6 volts. By pressing the SYNC button a second time John was able to retrieve the next alarm code, and repeated this process for the last alarm code.

Slow blinking



Fast blinking



Now that John discovered that the reason for the EEC system alarm code was low battery input voltage, he was able to focus on discovering the reason for this low battery voltage. After further investigation, he found two problems with his battery supply to the control system. The first problem is that only one battery power source was connected to the EEC system, rather than two battery sources (see section 3.1 for more information).



Secondly, the battery source that was connected (generator battery) was very low in voltage due to a failed battery charger. John fixed the problem with the generator battery charger, which charged the generator battery, and the EEC system immediately began to operate. Later, John had his marine electrician install a wire and circuit breaker to his house (domestic) battery source to provide a second battery source for the EEC system.



Alarm Codes Description chart

Check alarm code values that you recorded on the preceding page with the list of alarm code descriptions below. Enter the description in the appropriate column on the chart.

LEDs SLOW BLINKING				LEDs FAST BLINKING				ALARM CODE DESCRIPTION
TAKE PORT N	SYNC ACTIVE	WARM WARM	TROLL STBD N	TAKE PORT N	SYNC ACTIVE	WARM WARM	TROLL STBD N	
								Detected multiple handles with the same handle ID at startup.
								No handle connected at startup.
								Handle #1 PORT potentiometer reading below 0.25V or above 4.75V.
								Handle #2 PORT potentiometer reading below 0.25V or above 4.75V.
								Handle #3 PORT potentiometer reading below 0.25V or above 4.75V.
								Handle #4 PORT potentiometer reading below 0.25V or above 4.75V.
								Handle #5 PORT potentiometer reading below 0.25V or above 4.75V.
								Handle #6 PORT potentiometer reading below 0.25V or above 4.75V.
								Handle #1 STBD potentiometer reading below 0.25V or above 4.75V.
								Handle #2 STBD potentiometer reading below 0.25V or above 4.75V.
								Handle #3 STBD potentiometer reading below 0.25V or above 4.75V.
								Handle #4 STBD potentiometer reading below 0.25V or above 4.75V.
								Handle #5 STBD potentiometer reading below 0.25V or above 4.75V.
								Handle #6 STBD potentiometer reading below 0.25V or above 4.75V.
								**CP lost communication with Handle #1.
								**CP lost communication with Handle #2.
								**CP lost communication with Handle #3.
								**CP lost communication with Handle #4.
								**CP lost communication with Handle #5.
								**CP lost communication with Handle #6 (will not be stored).
** = Handle loosing communication will cause an alarm condition if handle is the active handle at time of fault								
								Detected multiple actuators with the same actuator ID at startup.
								CP actuator configuration does not match actuator settings.
								CP lost communication with actuator #1 (port throttle / gear).
								CP lost communication with actuator #2 (stbd throttle / gear).
								CP lost communication with actuator #3 (port / stbd troll).
								CP lost communication with actuator #4 (port / stbd throttle / electronic gear).
								CP lost communication with actuator #6 (center throttle / gear).

LEDs SLOW BLINKING				LEDs FAST BLINKING				ALARM CODE DESCRIPTION
TAKE PORT N	SYNC ACTIVE	WARM WARM	TROLL STBD N	TAKE PORT N	SYNC ACTIVE	WARM WARM	TROLL STBD N	
								Actuator # 1 battery input below 11.5V / 23V (code not stored in history).
								Actuator # 1 battery input above 16V / 30V (code not stored in history).
								Actuator # 1 battery input below 9V / 18V.
								Actuator # 1 battery input above 17V / 32V.
								Actuator # 1 battery reading does not match 12 or 24V input range.
								Actuator # 1 — PORT throttle exceeded 5A for more than 6 seconds.
								Actuator # 1 — PORT throttle can't reach commanded position.
								Actuator # 1 — PORT throttle feedback more than 4.80V or less than 0.20V.
								Actuator # 1 — PORT gear exceeded 5A for more than 6 seconds.
								Actuator # 1 — PORT gear can't reach commanded position.
								Actuator # 1 — PORT gear feedback more than 4.80V or less than 0.20V.
								Actuator # 1 — PORT actuator solenoid not locked down.
								Actuator #2 — battery input below 11.5V / 23V (code not stored in history).
								Actuator #2 — battery input above 16V / 30V (code not stored in history).
								Actuator #2 — battery input below 9V / 18V.
								Actuator #2 — battery input above 17V / 32V.
								Actuator # 2 battery reading does not match 12 or 24V input range.
								Actuator # 2 — STBD throttle exceeded 5A for more than 6 seconds.
								Actuator # 2 — STBD throttle can't reach commanded position.
								Actuator # 2 — STBD throttle feedback more than 4.80V or less than 0.20V.
								Actuator # 2 — STBD gear exceeded 5A for more than 6 seconds.
								Actuator # 2 — STBD gear can't reach commanded position.
								Actuator # 2 — STBD gear feedback more than 4.80V or less than 0.20V.
								Actuator # 2 — STBD actuator solenoid not locked down.
								Actuator #3 — battery input below 11.5V / 23V (code not stored in history).
								Actuator #3 — battery input above 16V / 30V (code not stored in history).
								Actuator #3 — battery input below 9V / 18V.
								Actuator #3 — battery input above 17V / 32V.
								Actuator #3 battery reading does not match 12 or 24V input range.
								Actuator #3 — PORT troll exceeded 5A for more than 6 seconds.
								Actuator #3 — PORT troll can't reach commanded position.
								Actuator #3 — PORT troll feedback more than 4.80V or less than 0.20V.
								Actuator #3 — STBD troll exceeded 5A for more than 6 seconds.
								Actuator #3 — STBD troll can't reach commanded position.
								Actuator #3 — STBD troll feedback more than 4.80V or less than 0.20V.

LEDs SLOW BLINKING				LEDs FAST BLINKING				ALARM CODE DESCRIPTION
TAKE PORT N	SYNC ACTIVE	WARM WARM	TROLL STBD N	TAKE PORT N	SYNC ACTIVE	WARM WARM	TROLL STBD N	
								Actuator #4 — battery input below 11.5V / 23V (code not stored in history).
								Actuator #4 — battery input above 16V / 30V (code not stored in history).
								Actuator #4 — battery input below 9V / 18V.
								Actuator #4 — battery input above 17V / 32V.
								Actuator # 4 — battery reading does not match 12 or 24V input range.
								Actuator #4 — PORT throttle exceeded 5A for more than 6 seconds.
								Actuator #4 — PORT throttle can't reach commanded position.
								Actuator #4 — PORT throttle feedback more than 4.80V or less than 0.20V.
								Actuator #4 — STBD throttle exceeded 5A for more than 6 seconds.
								Actuator #4 — STBD throttle can't reach commanded position.
								Actuator #4 — STBD throttle feedback more than 4.80V or less than 0.20V.
								Actuator #6 — battery input below 11.5V / 23V (code not stored in history).
								Actuator #6 — battery input above 16V / 30V (code not stored in history).
								Actuator #6 — battery input below 9V / 18V.
								Actuator #6 — battery input above 17V / 32V.
								Actuator # 6 — battery reading does not match 12 or 24V input range.
								Actuator #6 — CENTER throttle exceeded 5A for more than 6 seconds.
								Actuator #6 — CENTER throttle can't reach commanded position.
								Actuator #6 — CENTER throttle feedback more than 4.80V or less than 0.20V.
								Actuator #6 — CENTER throttle exceeded 5A for more than 6 seconds.
								Actuator #6 — CENTER throttle can't reach commanded position.
								Actuator #6 — CENTER throttle feedback more than 4.80V or less than 0.20V.

7.0 Appendix / Reference

The Appendix / Reference section is divided as follows:

7.1 Wiring Diagrams (many other engine layouts available, contact GMP)

A. SINGLE Engine Wiring Diagram	41
B. TWIN Engine Wiring Diagram	42
C. TWIN Engine w/TROLL Wiring Diagram	43
D. TWIN Engine w/ELECTRIC GEAR Wiring Diagram	44
E. Smart Actuator Harnesses	45

7.2 Dimensional Drawings / Cutout Templates

A. Actuator Dimensions	49
B. 2-button Control Head (Remote) Dimensions	50
C. 2-button Control Head CP Dimensions	51
D. 4-button Control Head (Remote) Dimensions	52
E. 4-button Control Head CP Single Dimensions	53
F. Smart Actuator Mounting Dimensions	54
G. Cutout templates for Control Heads	55

7.3 Mechanical Backup Control (optional)

A. Description	59
B. Operation	59
C. Installation	60
D. Installation Checkouts	68

7.4 Sidemount Controls Installation (optional)

A. Sidemount Handle Control Assembly	71
B. Sidemount Keypad Assembly	73
C. Sidemount Handle Control Dimensions	74
D. Sidemount Keypad Assembly Dimensions	75
E. Cutout template for Sidemount Keypad Assembly	76

7.5 Control Head Configuration (optional)

A. Configuring Control Head Identifier	79
--	----

7.6 Control Processor Configuration (optional)

7.6.1 Actuator Options	.82
7.6.2 Throttle on Top of Troll Options	.83
7.6.3 Troll Delay Options	.84
7.6.4 Throttle Delay Options	.85
7.6.5 Gear Delay Options	.86
7.6.6 Hi-Idle Step Size (part 1)	.87
7.6.7 Hi-Idle Step Size (part 2)	.88
7.6.8 System Startup Options	.89
7.6.9 Station Transfer Options	.90
7.6.10 Return Settings to Default Option	.91
7.6.11 Sync Gain Options	.92
7.6.12 Mechanical Backup Options	.93

7.7 Smart Actuator Configuration (optional)

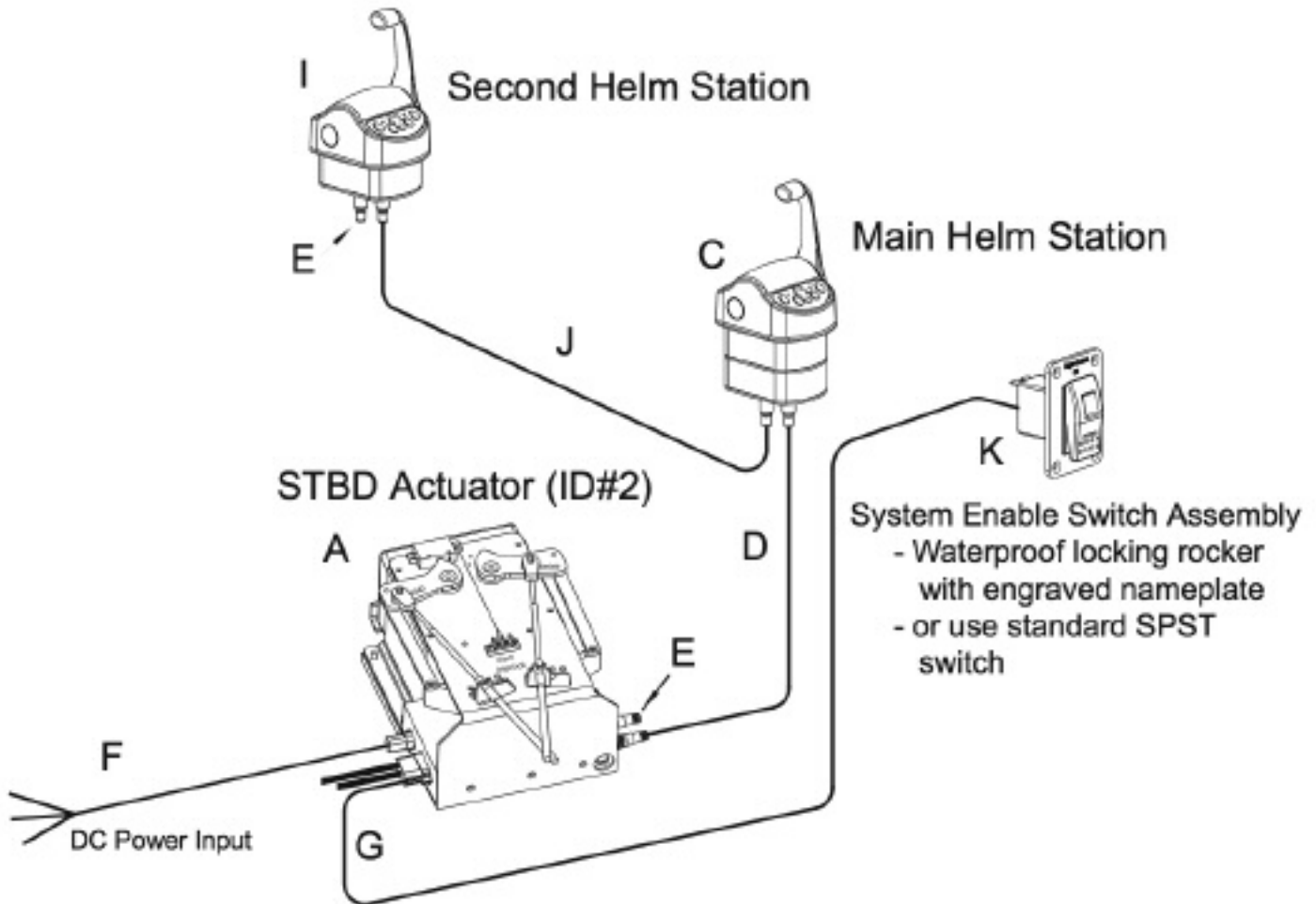
7.7.1 Setting the Actuator Default Option	.95
7.7.2 Setting the Actuator Identifier	.96
7.7.3 Setting the Tachometer Pulses / Revolution (PPR)	.97
7.7.4 Setting the Cable Travel Direction ONLY	.98

7.8 Triple Engine Applications (optional)

A. Description	.101
B. Operation	.101
TRIPLE Engine Wiring Diagram	.102
TRIPLE Engine Harnesses	.103

SINGLE Engine Wiring Diagram

- Single Engine
- Mechanical Throttle
- Mechanical Gear
- Twin Helm Stations

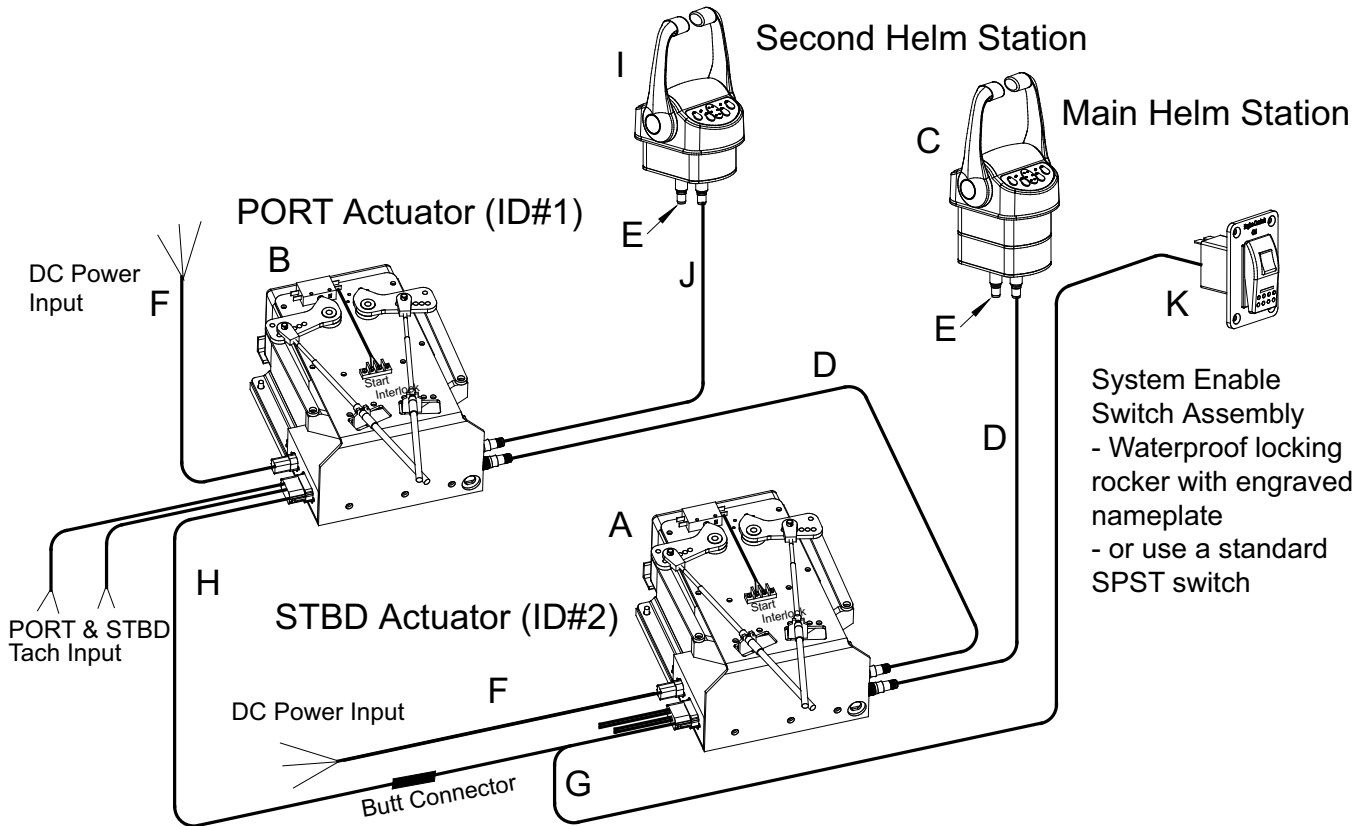


Typical Parts Required

Item	Qty	Part #	Description
A	(1)	11312-xx-TMG-S	Smart Actuator STBD (12 or 24v DC)
C	(1)	11413-CT-CP-SGL	CH2001 Control Head 4 button CP single
D	(1)	11600-02-XX	Station Cable (20 - 100' lengths)
E	(2)	11600-TRF	Terminating Resistors
F	(1)	11601-01	Harness - DC Power Input (30' length std.)
G	(1)	11603-02-SGL-xx	Harness - Enable Single (20 - 100' lengths)
Extra Control Station Requires			
I	(1)	11413-C15T-SGL	CH2001 Control Head 4 button Single
J	(1)	11600-02-xx	Station Cable (20 - 100' lengths)
Optional Enable Switch Assembly			
K	(1)	11490-x	Enable Switch Assembly (Black or White nameplate)

TWIN Engine Wiring Diagram

- Twin Engine
- Mechanical Throttle
- Mechanical Gear
- Twin Helm Stations

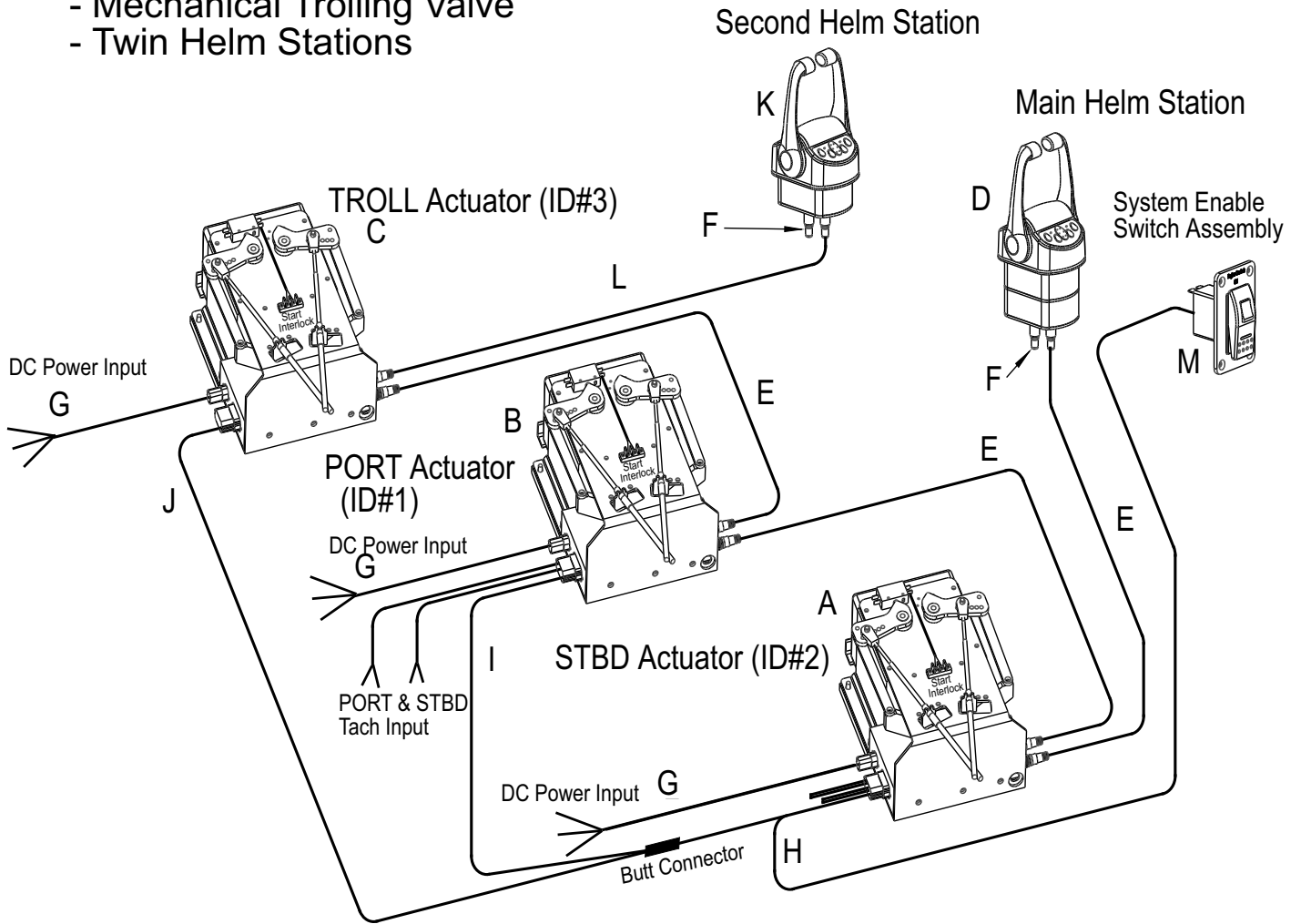


Typical Parts Required

Item	Qty	Part #	Description
A	(1)	11312-xx-TMG-S	Smart Actuator STBD (12 or 24v DC)
B	(1)	11312-xx-TMG-P	Smart Actuator PORT (12 or 24v DC)
C	(1)	11413-CT-CP	CH2001 Control Head 4 button CP
D	(2)	11600-02-xx	Station Cables (20 - 100' long)
E	(2)	11600-TRF	Terminating Resistors
F	(2)	11601-01	Harness - DC Power Input (30' long std.)
G	(1)	11603-02-S-xx	Harness - Enable STBD (20-100'long)
H	(1)	11603-02-P	Harness - Enable/Tach PORT (30' long std.)
Extra Control Station requires			
I	(1)	11413-C15T	CH2001 Control Head 4 button
J	(1)	11600-02-xx	Station Cable (20-100' long)
Optional Enable Switch Assembly			
K	(1)	11490-x	Enable Switch Assembly (Black or White nameplate)

TWIN Engine w/TROLL Wiring Diagram

- Twin Engine
- Mechanical Throttle
- Mechanical Gear
- Mechanical Trolling Valve
- Twin Helm Stations

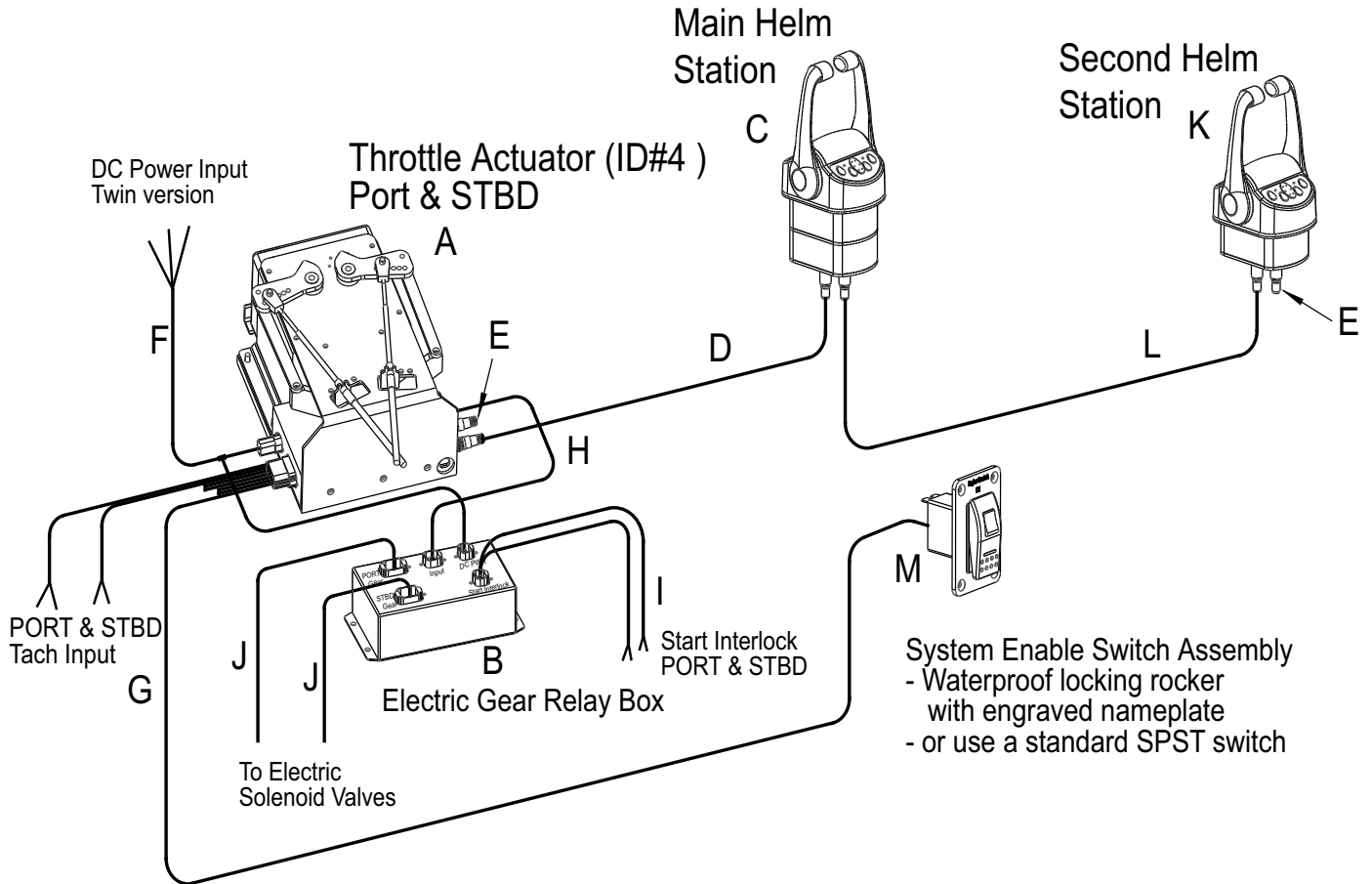


Typical Parts Required

Item	Qty	Part #	Description
A	(1)	11312-xx-TMG-S	Smart Actuator STBD (12 or 24v DC)
B	(1)	11312-xx-TMG-P	Smart Actuator PORT (12 or 24v DC)
C	(1)	11312-xx-TROLL	Smart Actuator TROLL (12 or 24v DC)
D	(1)	11413-CT-CP	CH2001 Control Head 4 button CP
E	(3)	11600-02-XX	Station Cable (20 - 100' lengths)
F	(2)	11600-TRF	Terminating Resistors
G	(3)	11601-01	Harness - DC Power Input (30' length std.)
H	(1)	11603-02-S-xx	Harness - Enable STBD (20 - 100' lengths)
I	(1)	11603-02-P	Harness - Enable/Tach PORT (30' length std)
J	(1)	11603-02-TROLL	Harness - Enable TROLL (30' length)
Extra Control Station Requires			
K	(1)	11413-C15T	CH2001 Control Head 4 button
L	(1)	11600-02-xx	Station Cable (20 - 100' lengths)
Optional Enable Switch Assembly			
M	(1)	11490-x	Enable Switch Assembly (Black or White nameplate)

TWIN Engine w/ELECTRIC Gear Wiring Diagram

- Twin Engine
- Mechanical Throttle
- Electric Gear
- Twin helm station



Typical Parts Required			
Item	Qty	Part #	Description
A	(1)	11312-xx-TEG	Smart Actuator Throttle/Electric Gear (12 or 24v DC)
B	(1)	11705-xx	Electric Gear Relay Output Box (12 or 24v DC)
C	(1)	11413-CT-CP-TEG	CH2001 Control Head 4 button CP
D	(1)	11600-02-xx	Station Cable (20 - 100' lengths)
E	(2)	11600-TRF	Terminating Resistors
F	(1)	11601-02	Harness - DC Power Input Twin (30' length std.)
G	(1)	11603-02-TEG-xx	Harness - Enable TEG (20 - 100' lengths)
H	(1)	11609-03-xx	Harness - Interconnect (12 or 24v DC)
I	(1)	11602-01	Harness - Start Interlock (30' length std.)
J	(1)	11604-L1-xx	Harness - Gear ZF IRM (10 - 30' lengths)
Extra Control Station Requires			
K	(1)	11413-C15T	CH2001 Control Head 4 button
L	(1)	11600-02-xx	Station Cable (20 - 100' lengths)
Optional Enable Switch Assembly			
M	(1)	11490-x	Enable Switch Assembly (Black or White nameplate)

Complete Control - Smart Actuator Harnesses

Station Cable
Part # 11600-02-xx' (available 20' - 100' in 20' increments)

NOTE: Connector Nut must turn 6 turns to ensure a complete connection

Connector is the same on both ends

Terminating Resistor
Part # 11600-TRF

Two required per system

DC Power Harness
Part # 11601-01 (30' long std.)

NOTE: Power wires are 30' long standard (custom lengths available)

Control Process End
Duetsch 4 pos. Black
(Noise Supression devices)

Battery Positive #1 (Red wire)
Battery Positive #2 (Red wire)
Battery Negative (yellow wire)

DC Power Harness - Twin Output Part # 11601-02 (30' long std.)

2 ft. 30 ft.

Note: Rear of connector shown

Smart Actuator - Single Engine Harness
Part # 11603-02-SGL-xx

SINGLE Enable Switch End
- see GMP Enable Switch Kit #11490-x
- or a SPST installer provided switch

(10' - 100' lengths avail. in 10' increments)
xx' in part number represents length of harness

White
Black

NOTE: DO NOT provide power to this end, only close the circuit using a N.O. switch

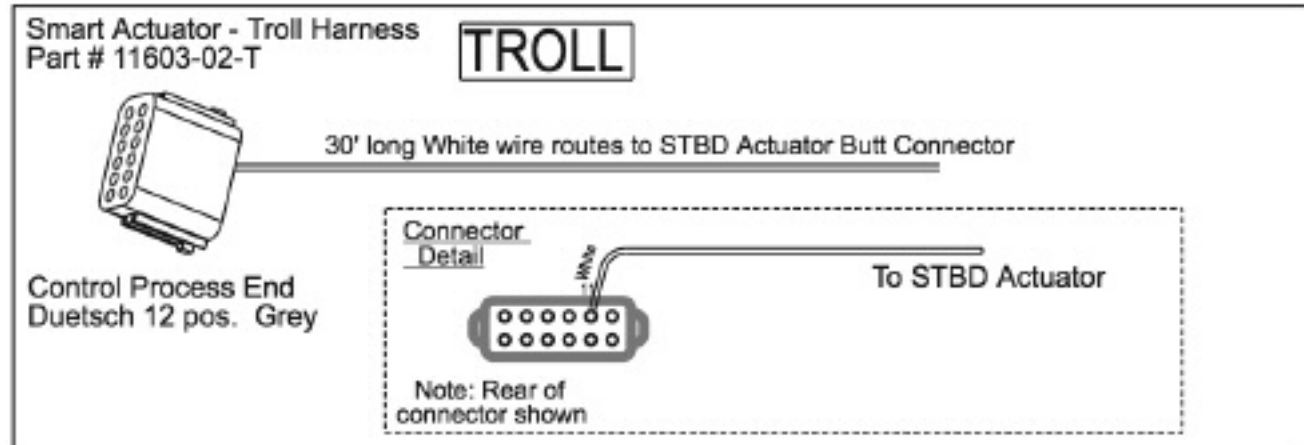
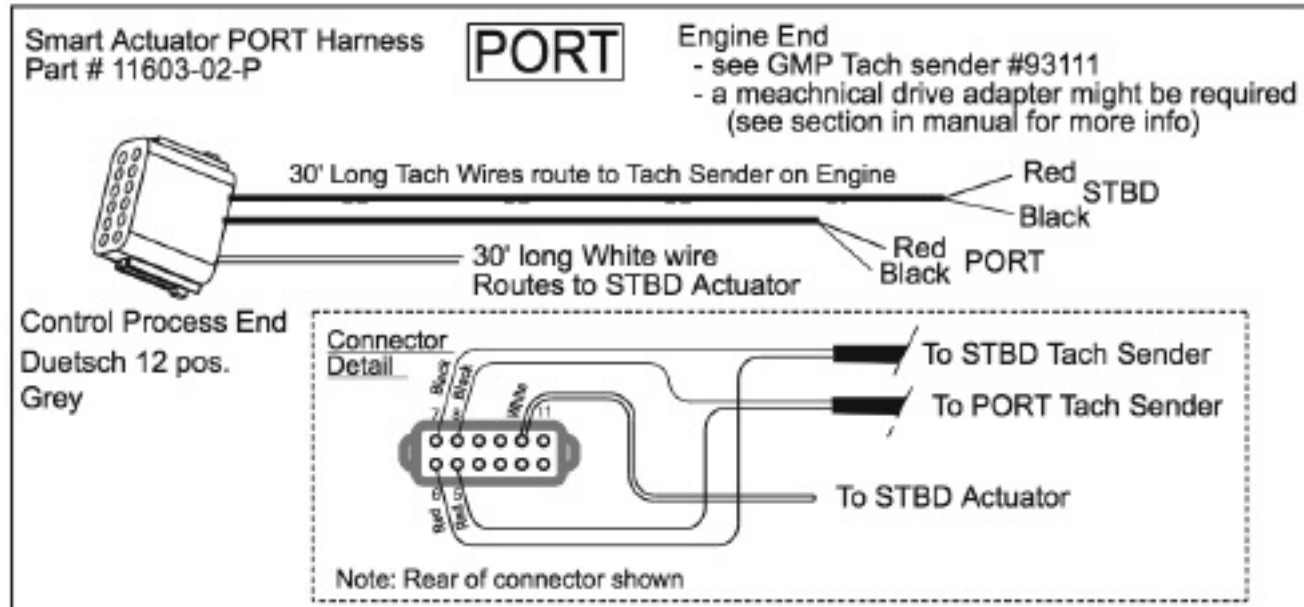
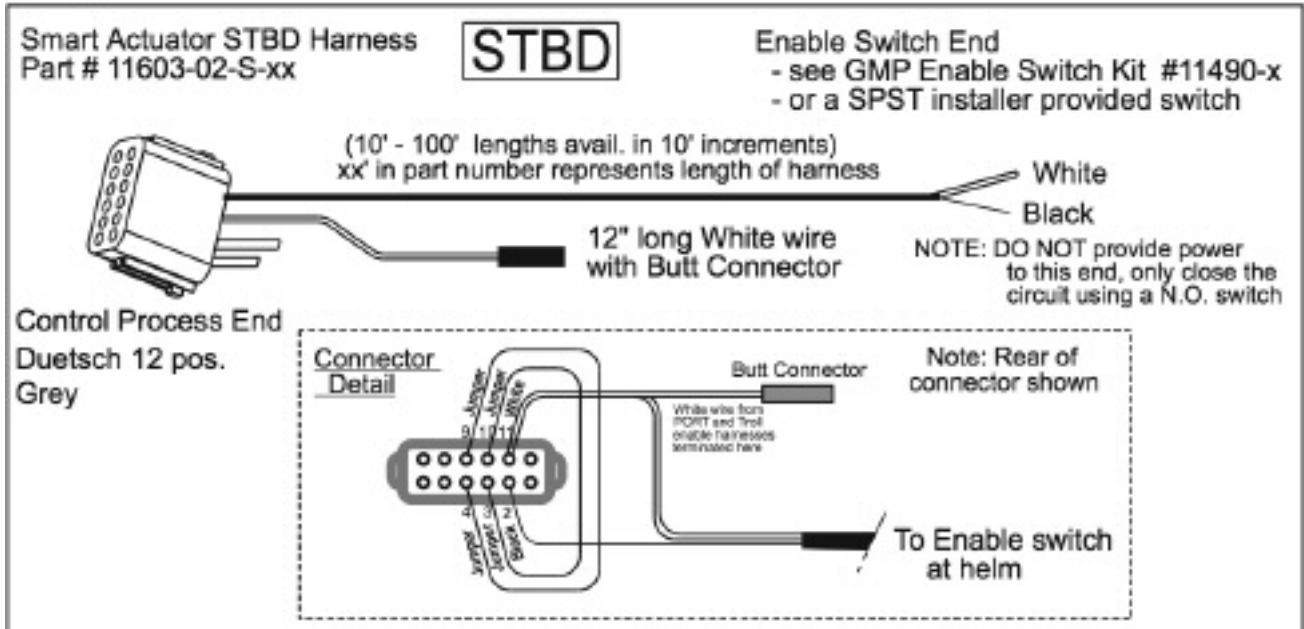
Control Process End
Duetsch 12 pos.
Grey

Connector Detail

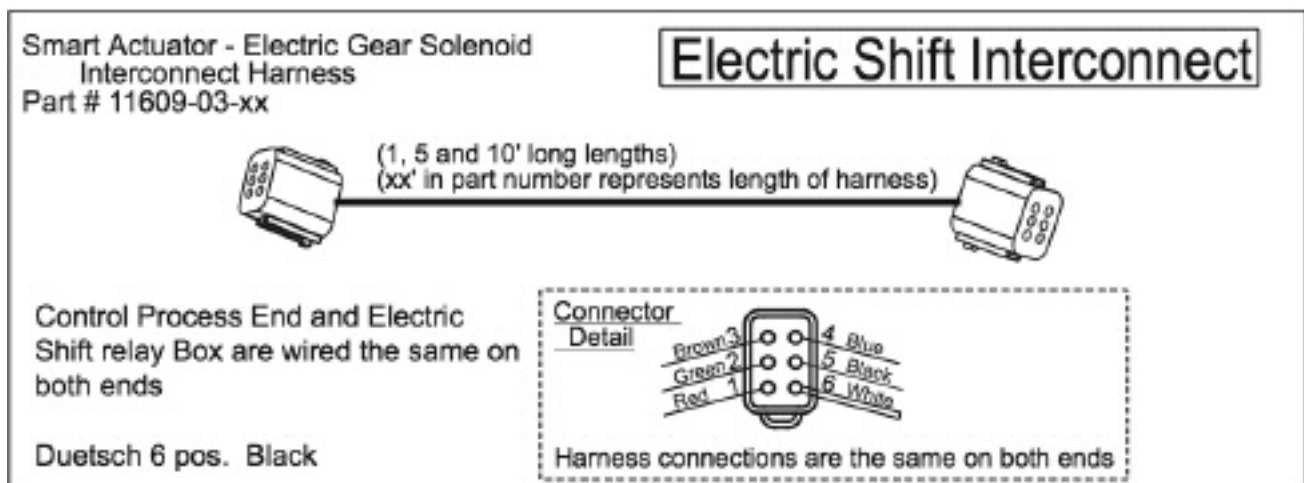
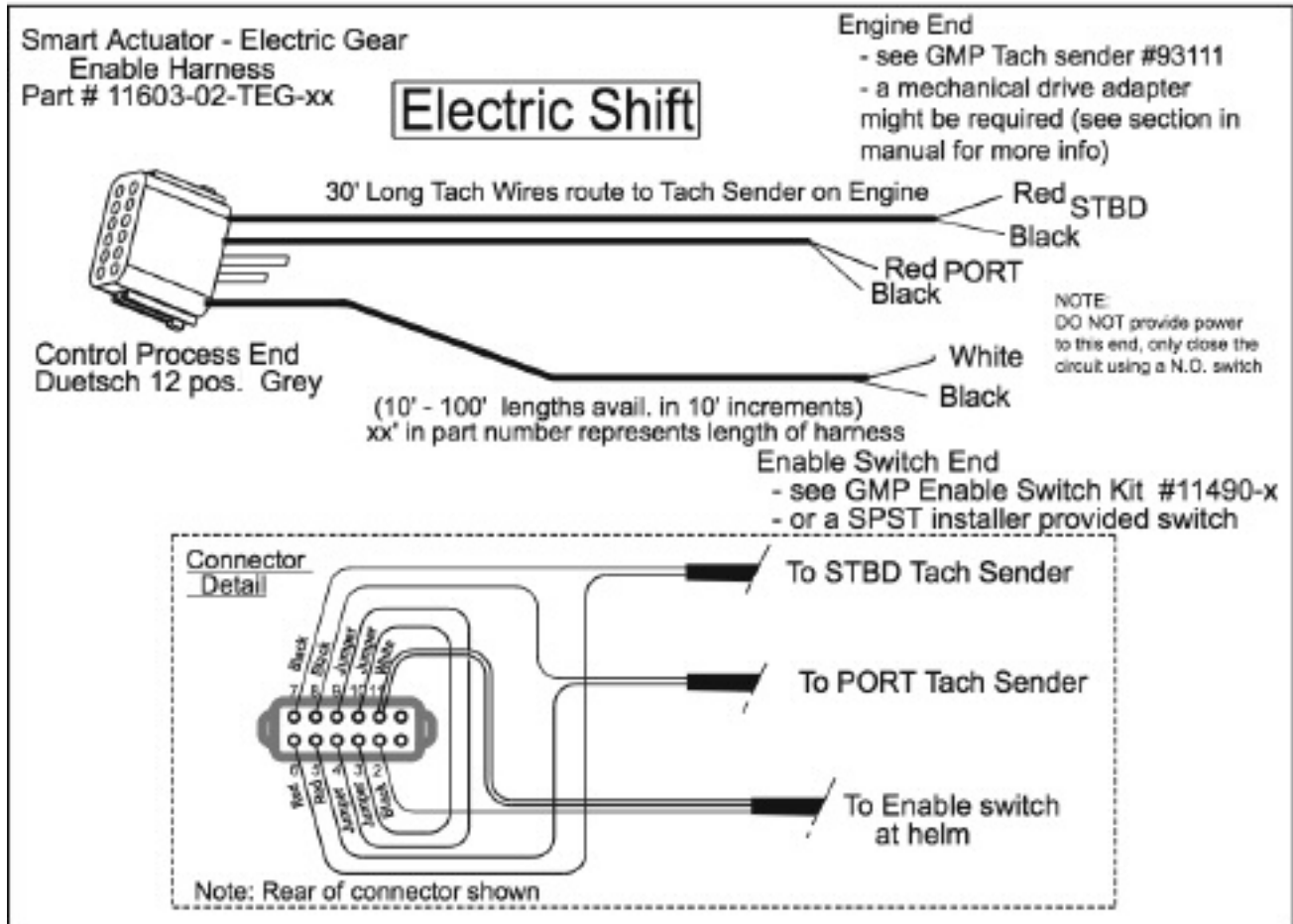
Note: Rear of connector shown

To Enable switch at helm

Complete Control - Smart Actuator Harnesses



Complete Control - Smart Actuator Harnesses



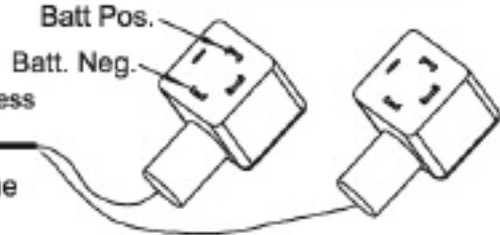
Complete Control - Smart Actuator Harnesses

Smart Actuator - Transmission Harness to Solenoid valves
Part # 11604-L1-xx

ZF Solenoid Valve Connectors
- with LED indicators



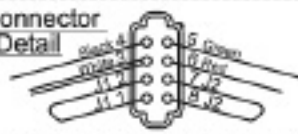
(5'- 30' lengths avail. in 5' increments)
xx' in part number represents length of harness



NOTE: Voltage output will be the same
as input to Relay Box

Control Processor End
Duetsch 8 pos. Grey

Connector
Detail



Note: Rear of connector shown

Connector
Detail

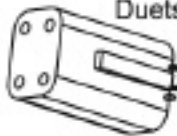


Start Interlock Harness
Part # 11602-01 (30' long std.)

NOTE: N.C. circuit between wires for PORT and STBD
Circuit OPENS when system is ON and
is NOT in Neutral position
8 amp max current

Control Process End
Duetsch 4 pos. Black

NOTE: Each start interlock wire is 30' long standard
(custom lengths available)

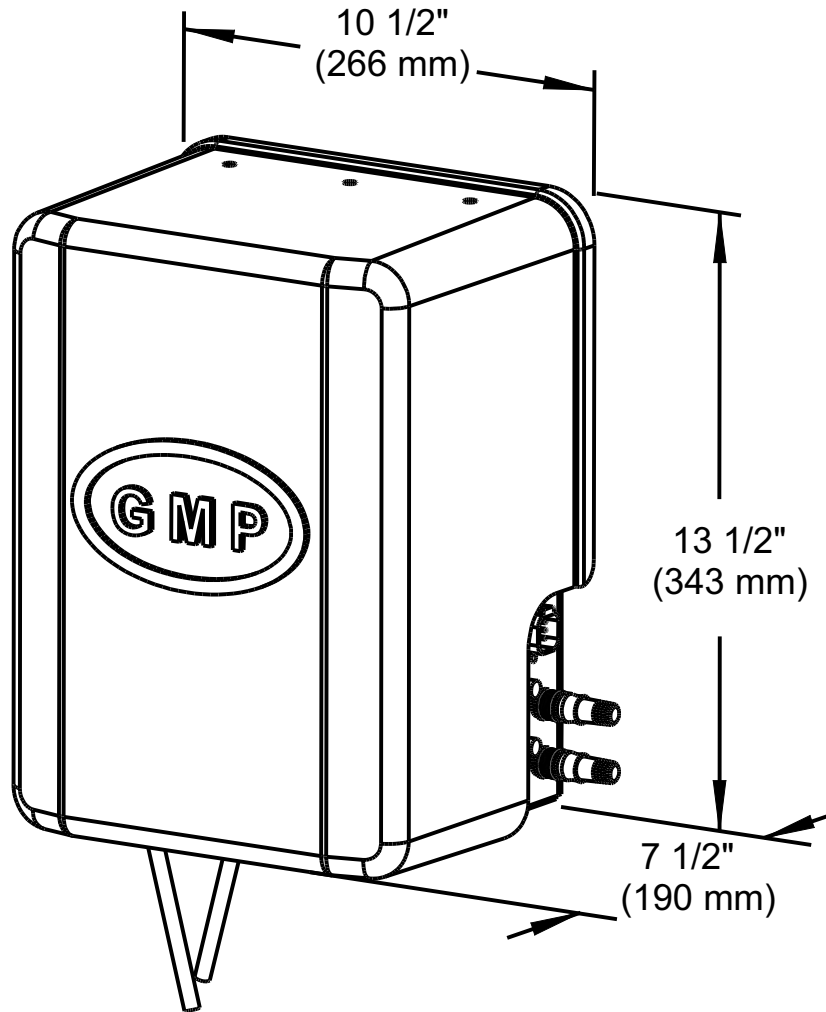


PORT
STBD
NOTE : All wires are yellow
with red stripe

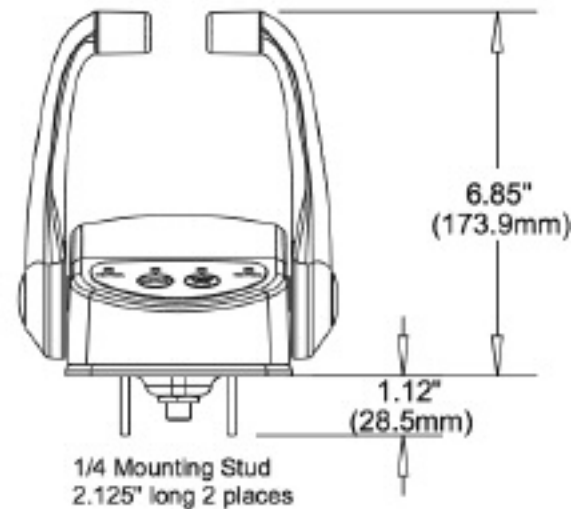
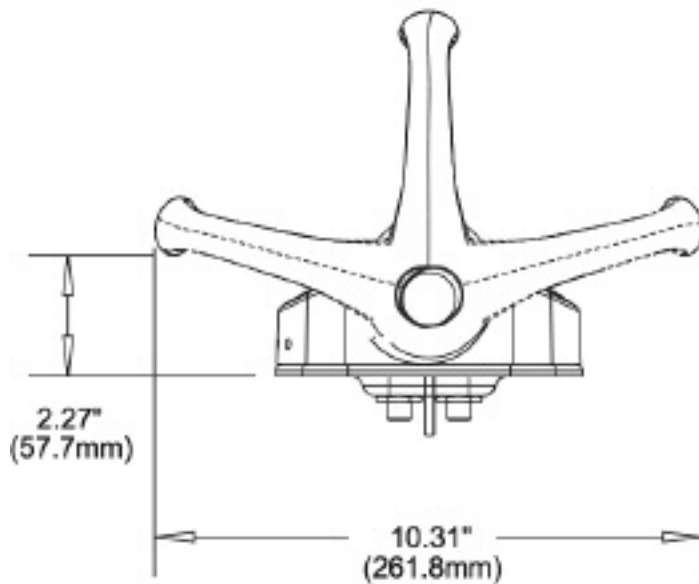
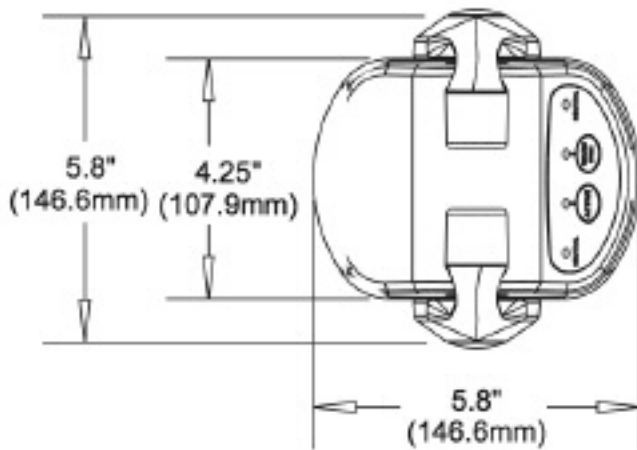
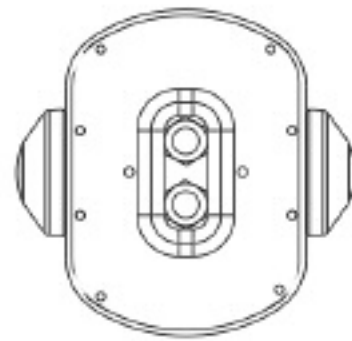


Note: Rear of connector shown

Actuator Dimensions

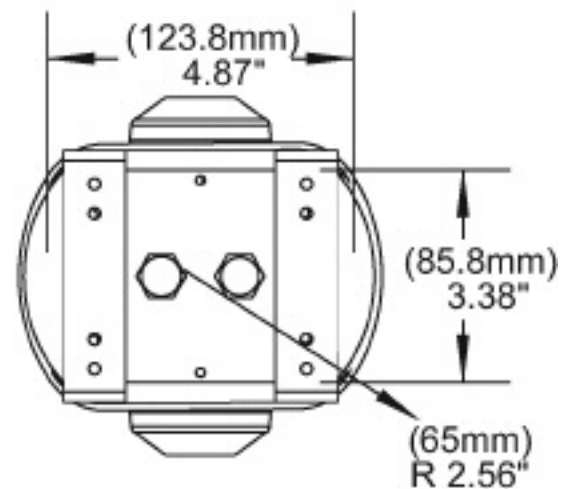
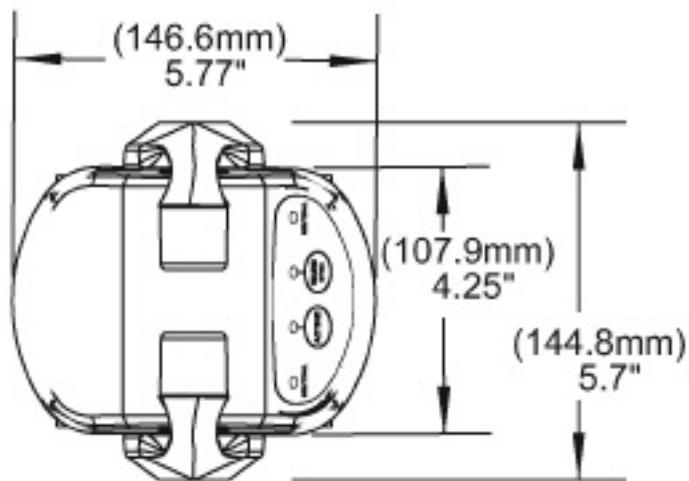
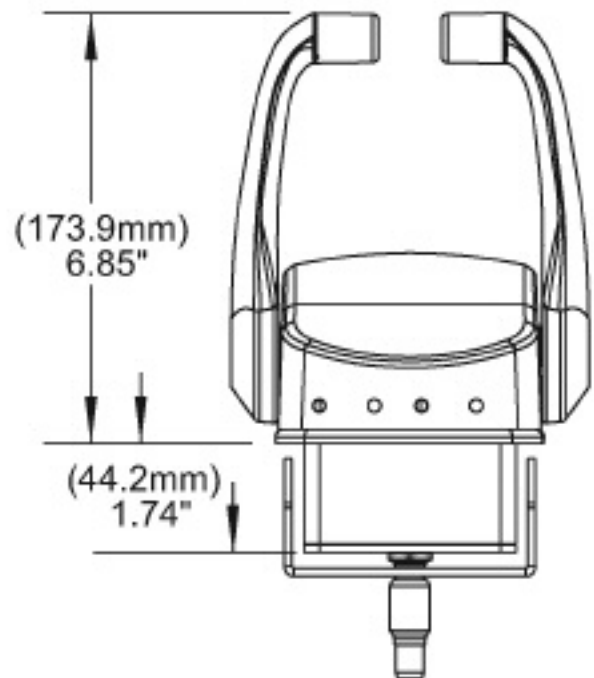
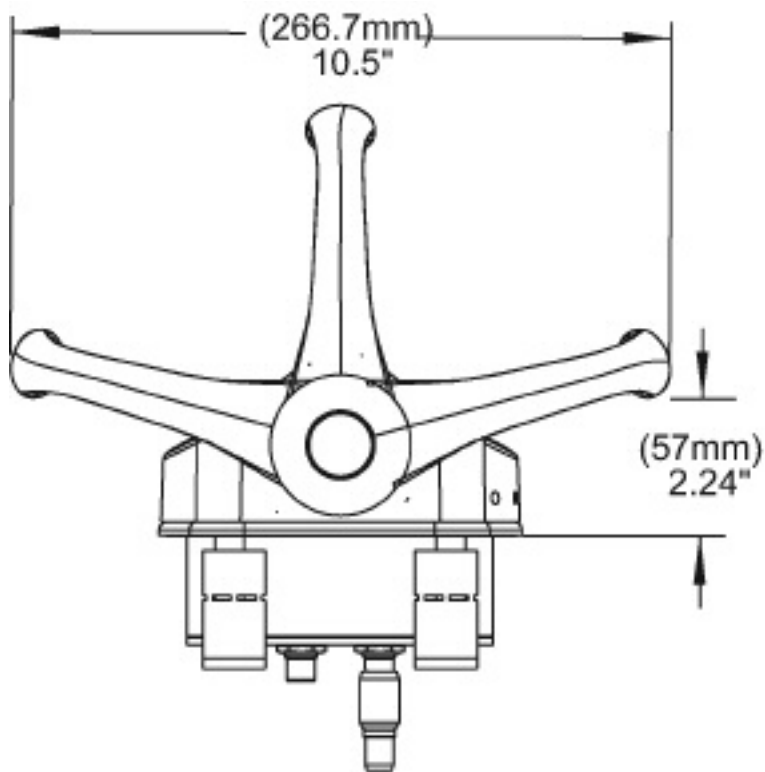


2-button Control Head (Remote) Dimensions

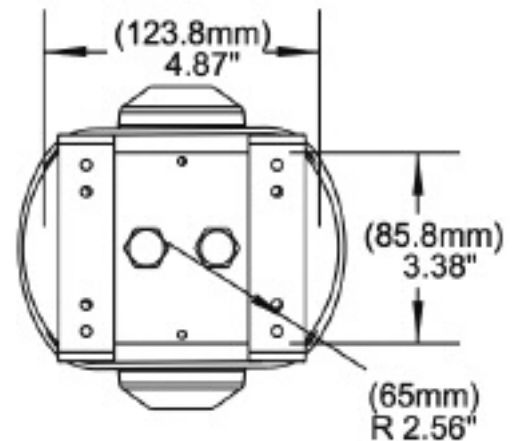
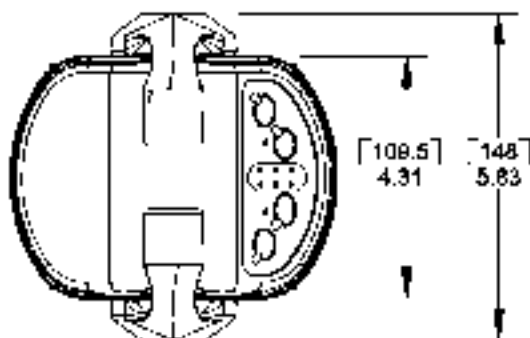
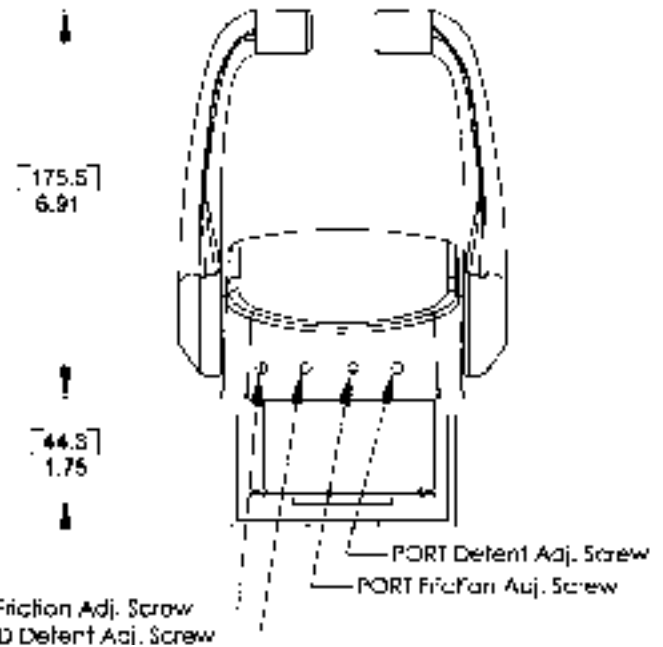
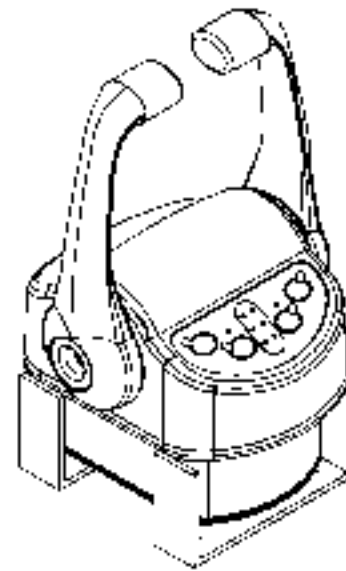
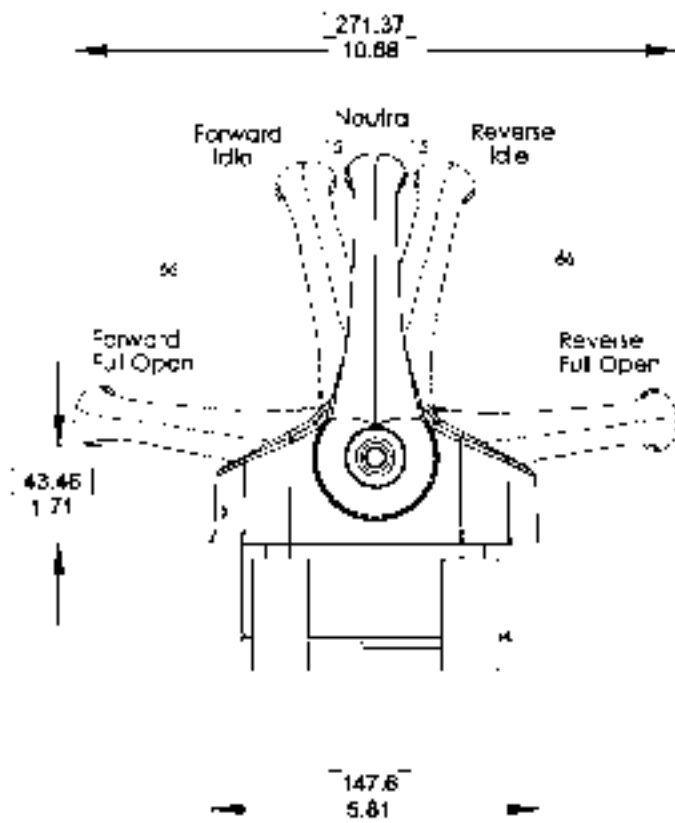


NOTE: 2.0" [51mm] required below connector for cable connector

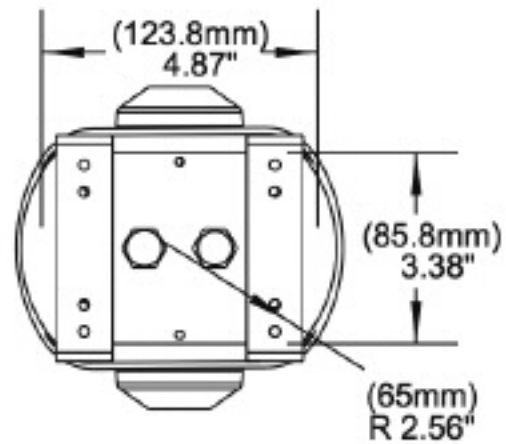
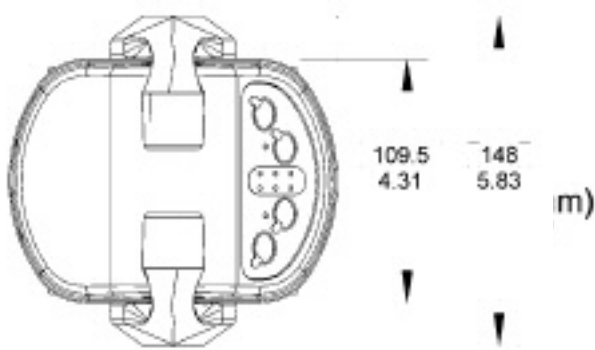
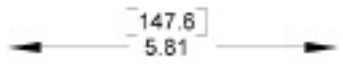
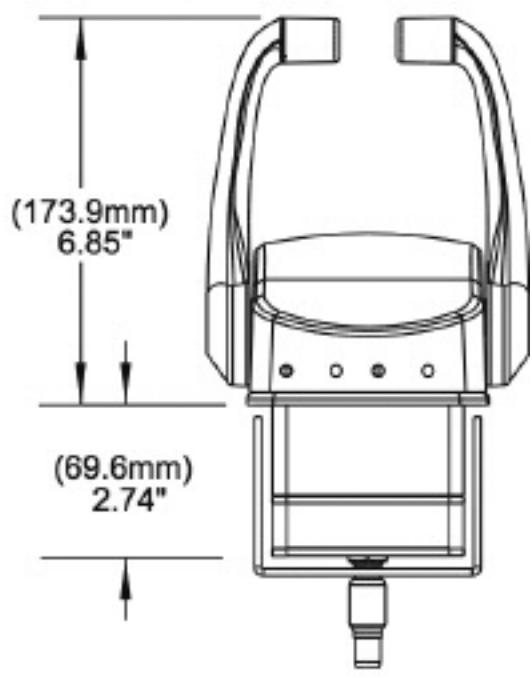
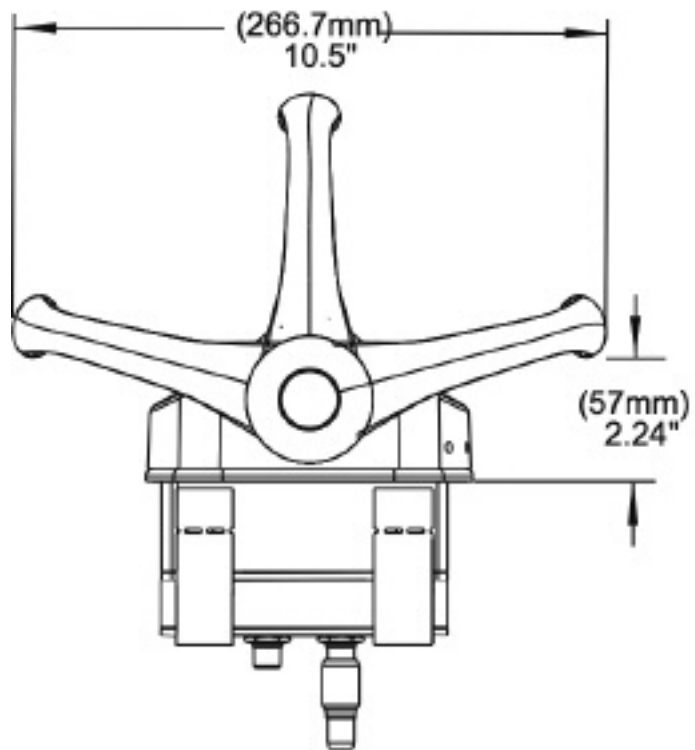
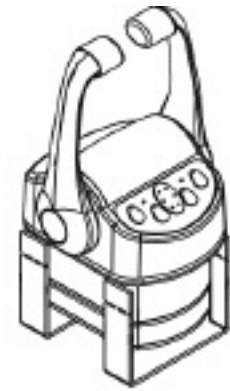
2-button Control Head CP Dimensions



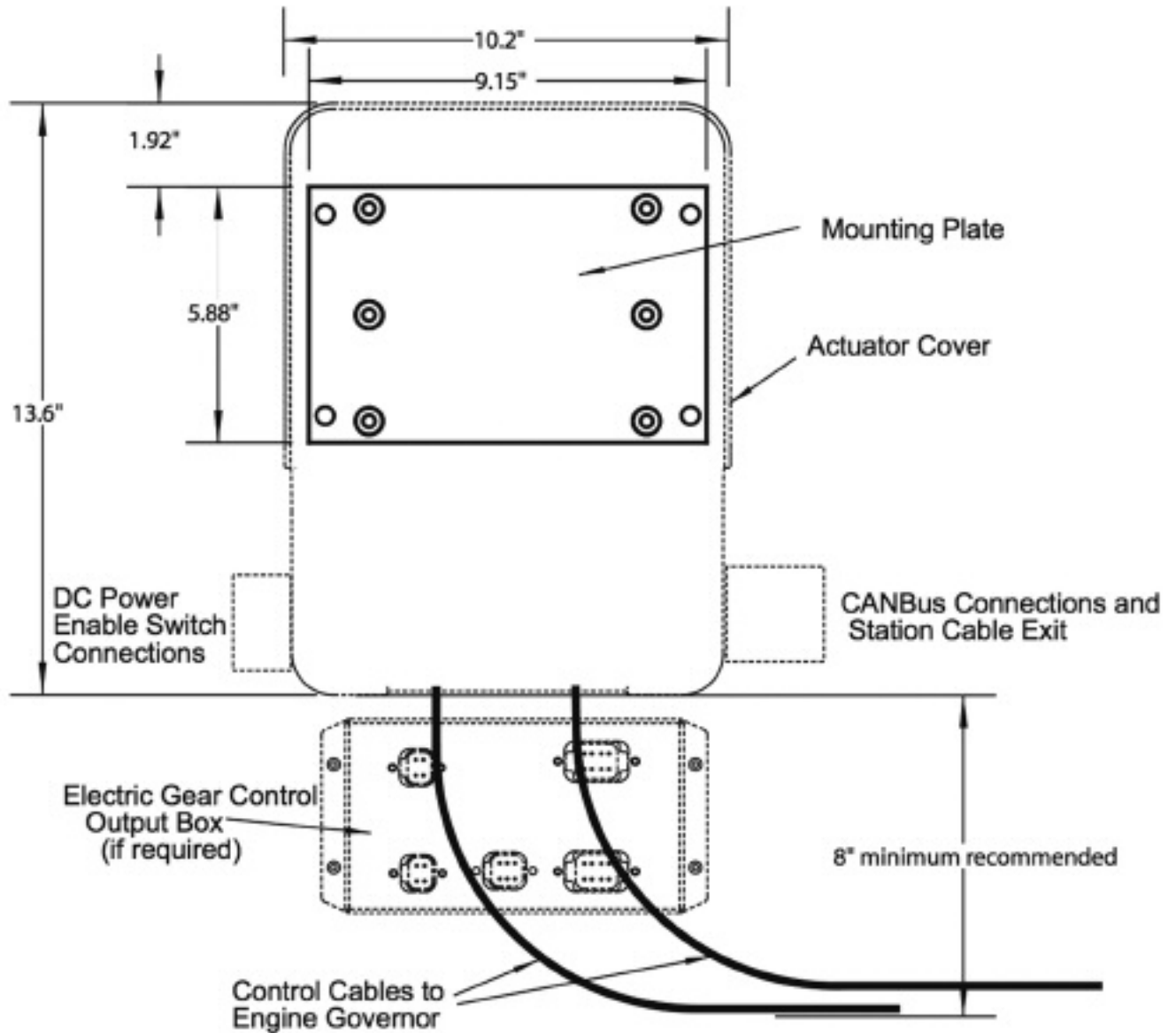
4-button Control Head (Remote) Dimensions



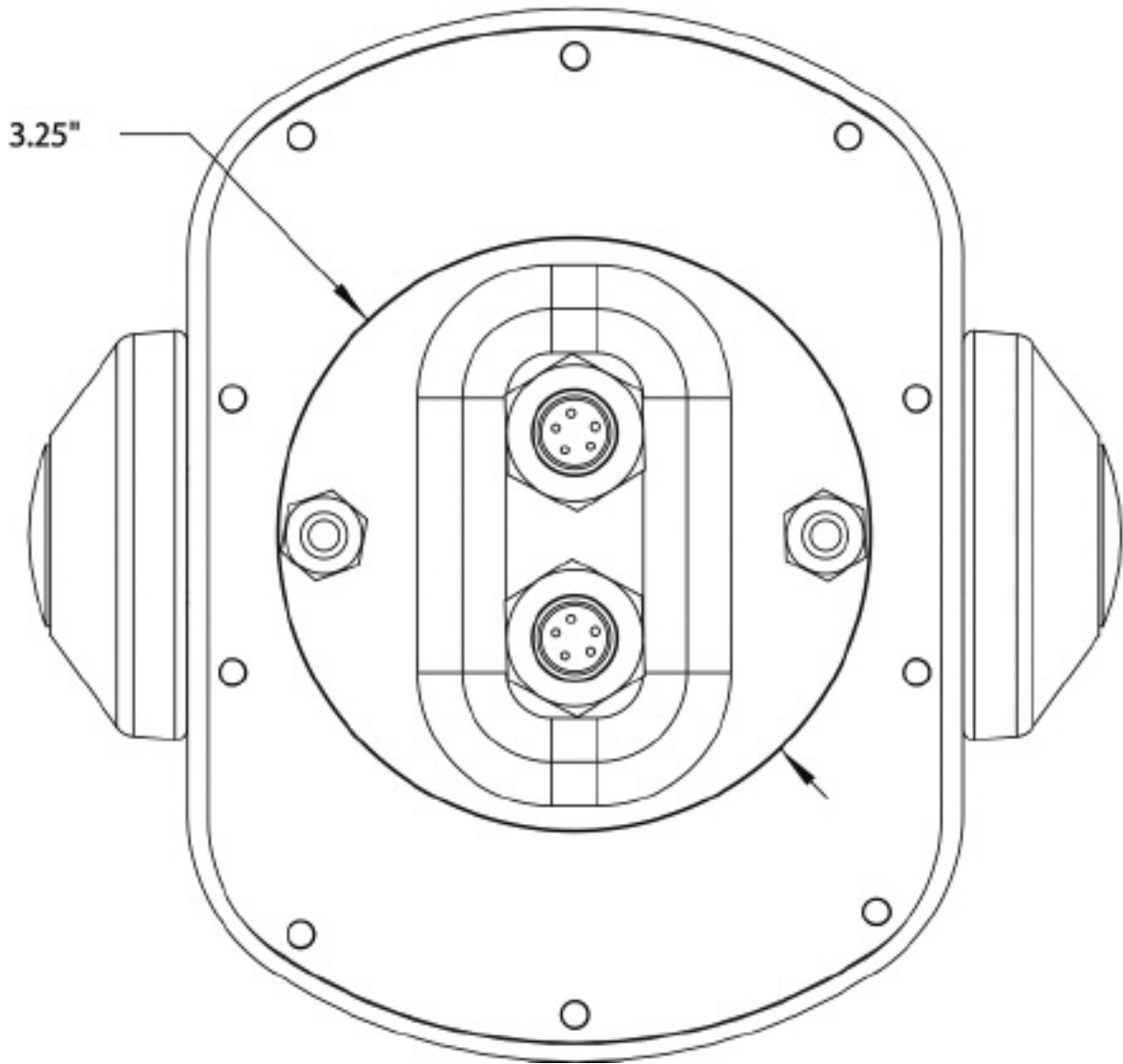
4-button Control Head CP Single Dimensions



Smart Actuator Mounting Dimensions

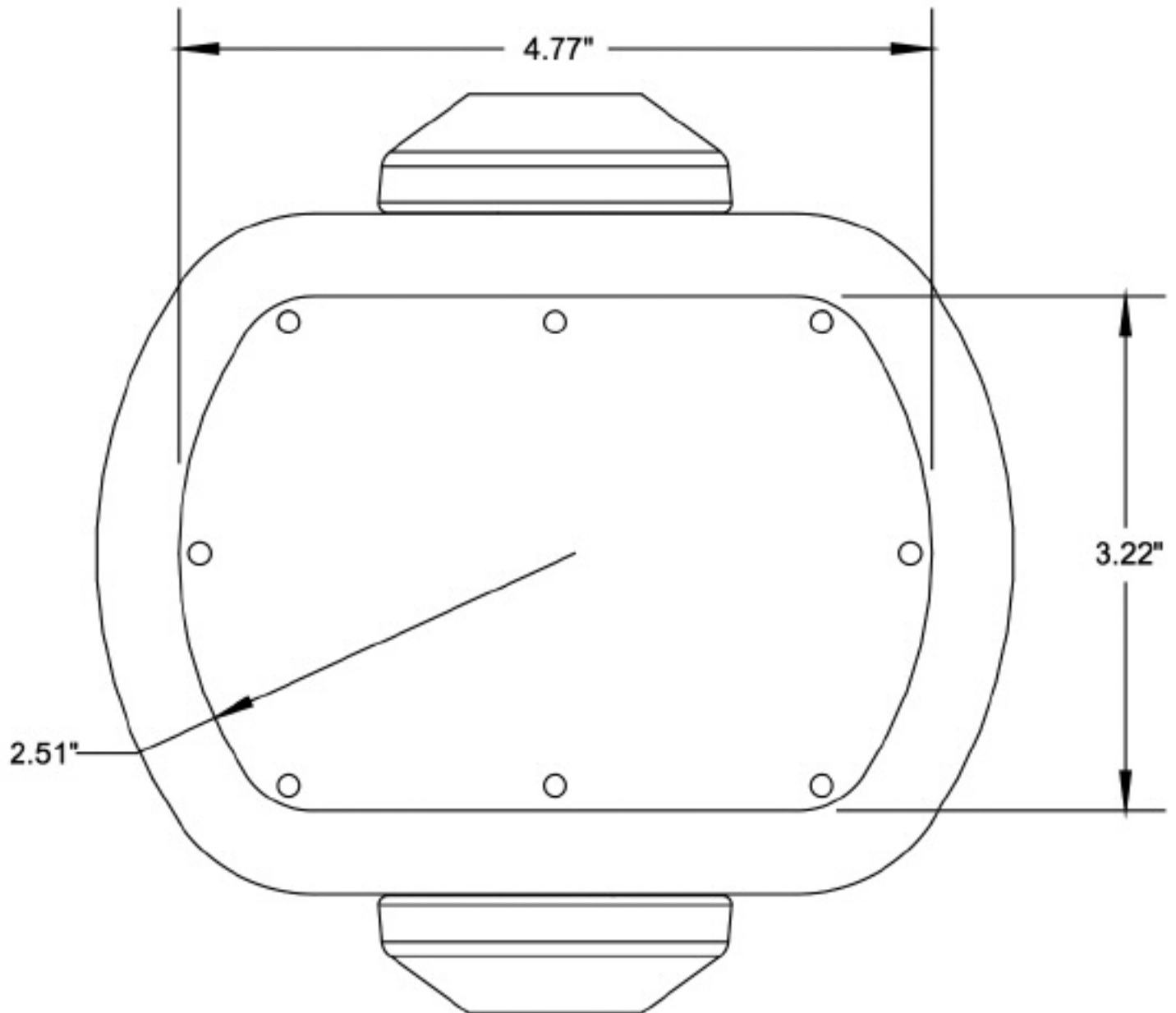


2-button Control Head (Remote) Cutout Template



Control Head Cutout Template for:

- 2-button Control Head CP
- 4-button Control Head (Remote)
- 4-button Control Head CP



7.3 Mechanical Backup Control (optional)

REFER TO SECTION 7.6.12 TO ENABLE MECHANICAL BACKUP FEATURE AFTER INSTALLING MECHANICAL BACKUP ACTUATOR.

A. Description

One of the key features of the Glendinning Smart Actuator Control system is the integrated mechanical backup option. In essence, the control system is a mechanical control that permits control of the gear and throttle from one designated “backup helm station.” While the system is in mechanical backup operation, the engine’s throttle and gear are controlled by a custom designed coupler mechanism on the top of the actuator, located in the engine room.

The Mechanical Backup Control option consists of the following components:

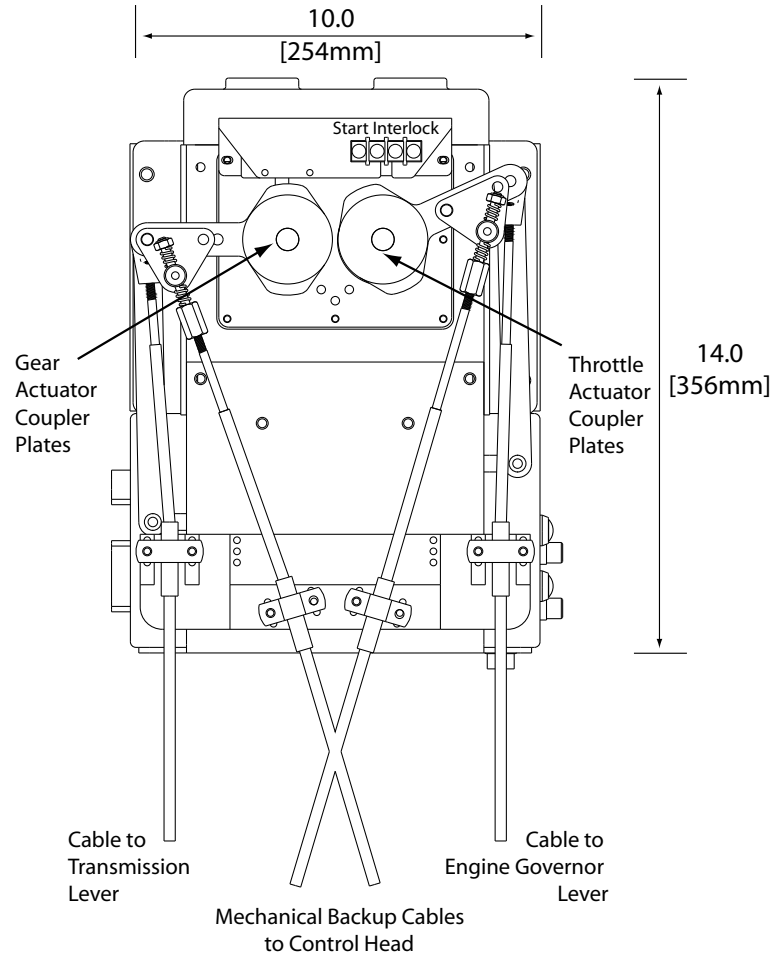
Dedicated Backup Control Head — any mechanical control head may be purchased for use with the Smart Actuator Mechanical Backup system. **This control head will be dedicated for use solely when the Smart Actuator system is in mechanical backup mode. When the system is in normal operating mode, this control head will NOT be in control of the boat’s propulsion system.**

Smart Actuator outfitted for backup control — this Actuator differs from the normal (non-backup) Smart Actuator and has been equipped with additional coupler plates, pins, and solenoid for mechanical operation of the engine’s gear and throttle.

Control Cables — to ensure good operation of the Smart Actuator Mechanical Backup Control, it is important that good quality control cables be used. Although the components are designed to accommodate any standard Type 33C control cable, (there are many grades and qualities of control cables available on the market) the quality of the control cables will have a direct impact on the function of the mechanical backup after installation is completed. We recommend using *NW Controls by Glendinning* — we consistently strive for control cables that achieve the highest efficiency, smoothest operation, and greatest flexibility of any control cables. On aftermarket installations, it is generally NOT recommended to reuse the existing control cables for mechanical backup operation.

B. Operation

Under normal operations, the gear and throttle are controlled by the Smart Actuator. Once there is a failure of the control system (indicated by all 4 LEDs on the Control Head blinking) the system will immediately go to neutral idle and the coupler pins on the Actuator will “pop” into place locking the coupler plates into mechanical operation. Operation of the Mechanical Backup Control is now possible only from the dedicated “backup helm station”. Once control has switched to mechanical operation, the backup helm station control handles need to be placed in the Neutral position (unless handles are already in Neutral). Once done, the backup helm station is in total mechanical control of both throttle and gear.



C. Installation

It cannot be emphasized strongly enough: the location of the Smart Actuators is the most important factor in satisfactory operation of the integrated mechanical backup option. The location of the Actuators has a direct impact on the routing of the control cables. In general, and almost without exception, there is a direct connection between good routing of the control cables and the operation of the mechanical backup system — good control cable routing will result in good mechanical backup operation, bad control cable routing will result in bad mechanical backup operation. Some factors which contribute to good Actuator location are the following:

- **Straight cable runs with the minimum number of bends** — The most efficient cable configuration is a straight cable run with no bends. Although this will yield maximum cable efficiency, it is not practical in a typical installation. Therefore to maximize cable efficiency, the Actuator locations should be chosen which will reduce or eliminate the total number of bends in the control cables (this includes the control cables which connect the Actuator to the engine/gear as well as the mechanical backup cables).
- **Cable bends should have a large radius** — The claims of the control cable manufacturers notwithstanding, control cables are far more efficient with larger diameter bends rather than smaller diameter. Where possible, large, sweeping turns should be used rather than smaller, tighter turns.

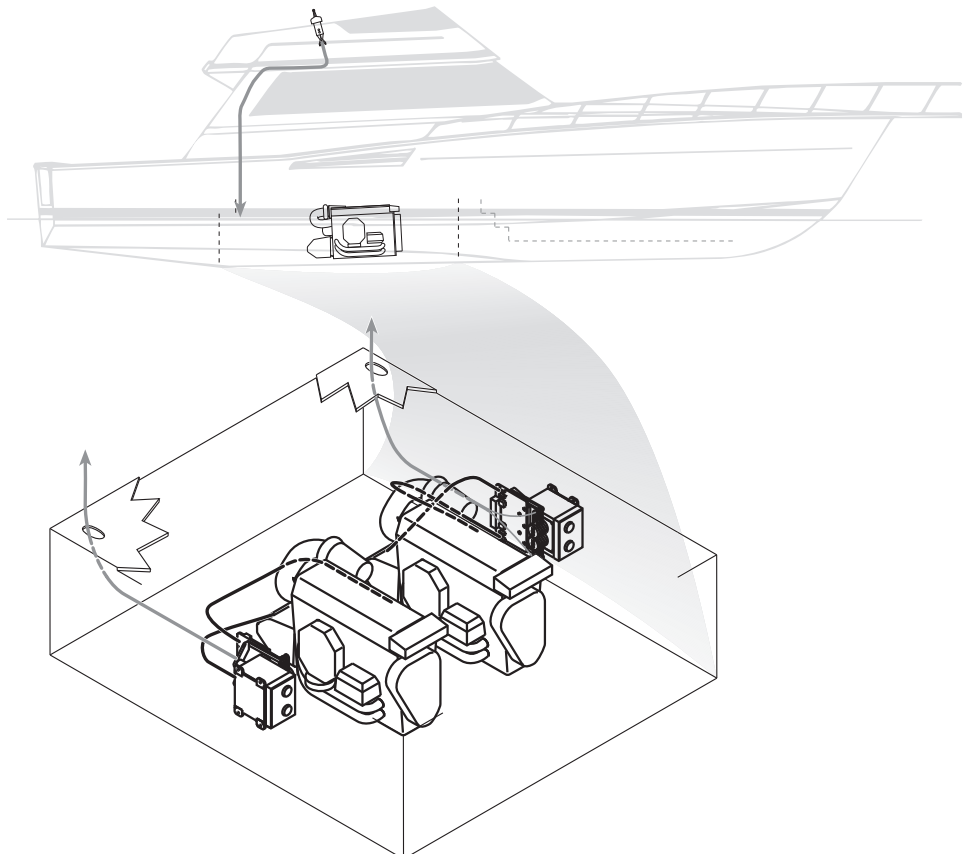
As an aid in determining the best location for the Smart Actuator system, several drawings have been prepared which depict some typical installations. Please review these drawings to see if any of these layouts would be applicable to your specific installation:

Aft-Starboard and Port Entry Ports

This drawing illustrates a typical location for the Actuators where the mechanical backup cables enter the engine compartment at the aft rear corners.

The Actuators are mounted on the outboard hull, with the Actuator control cable mounting plate oriented toward the aft end of the boat.

The control cables to the engine and gear make a “rear entry” and are connected to the Actuators through a single 180 degree bend.

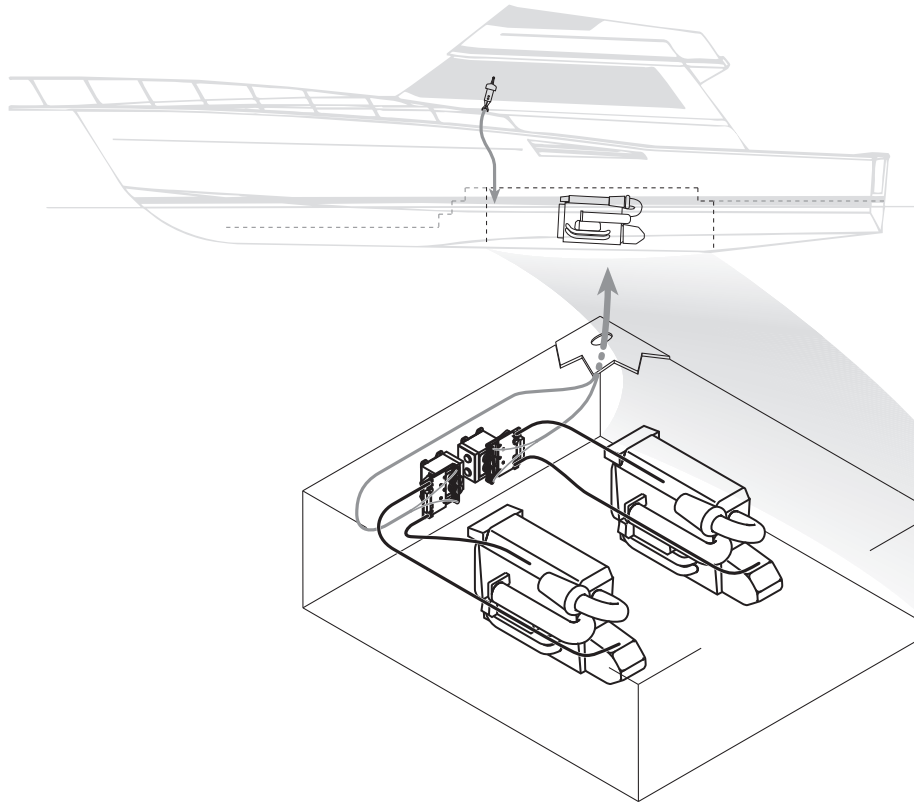


Forward-Starboard Entry Ports

This drawing illustrates a typical location for the Actuators where the mechanical backup cables enter the engine compartment at one of the forward corners.

The Actuators are mounted on the forward bulkhead, with the Actuator control cable mounting plate oriented toward the side of the engine compartment where the cables enter.

The control cables to the engine and gear make a “front entry” to the engine governor and are connected to the Actuators through a one or two 90 degree bends.

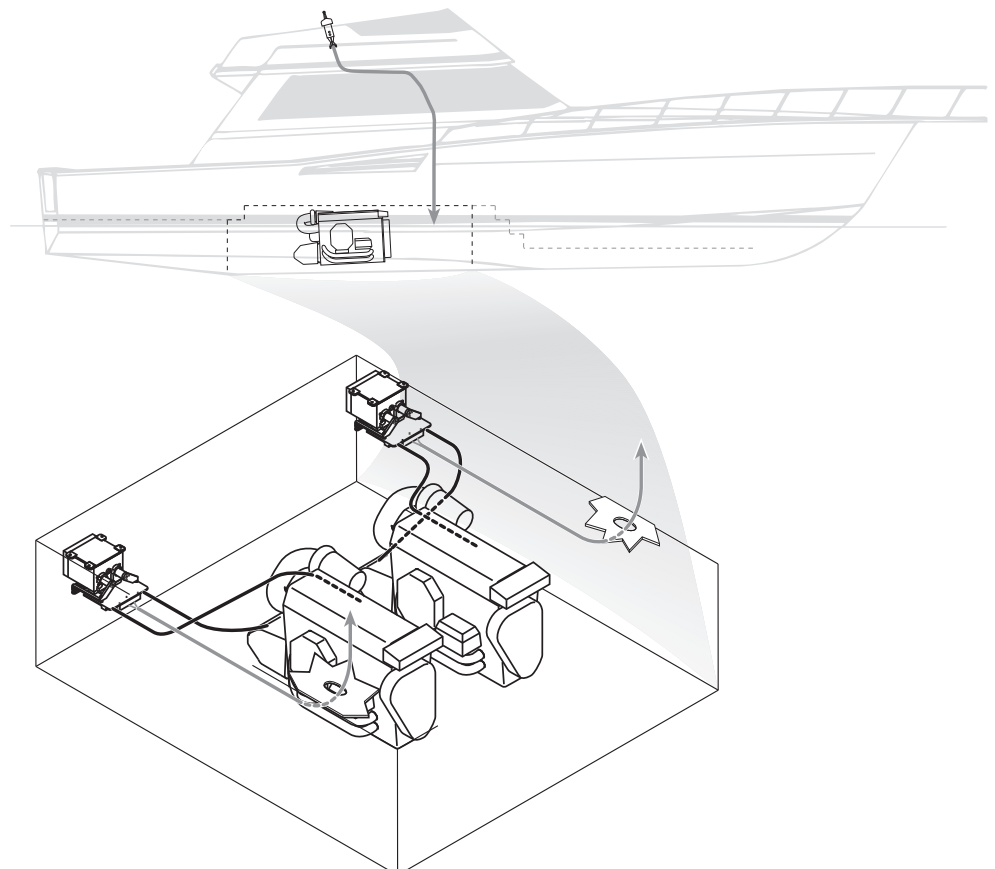


Mid-Starboard and Port Entry Ports

This drawing illustrates a typical location for the Actuators where the mechanical backup cables enter the engine compartment at the forward corners.

The Actuators are mounted on the overhead of the engine compartment at each rear corner, with the Actuator control cable mounting plate oriented toward the forward end of the engine compartment where the cables enter.

The control cables to the engine and gear make a “rear entry” to the engine governor and are connected to the Actuators through a one or two 90 degree bends.





As part of its service to its customers, Glendinning Marine Products, Inc. offers, at no charge to the customer, a plan review service for EEC system installations. In order to take advantage of this free service, fax or mail a sketch of the proposed installation to our EEC Application Manager. Although this sketch can be very simple, it should show the general arrangement of the engine and gearbox, points of attachment for the control cables, location for mechanical backup cable entry into the engine room, and proposed location of EEC system components.

The **primary factor in choosing a location for the actuators** is finding a location that results in the shortest, most direct path for the push-pull cable that connects each actuator to the transmission and engine governor. In general, for engines where the control cable travels aft from the engine governor / throttle lever, the throttle actuator will be mounted in the aft section of the engine room. Conversely, for engines where the control cable heads forward from the engine governor lever, the actuator will be mounted toward the forward end of the engine room. In general, the length of the control cable from each actuator to the transmission and engine governor should not be greater than 10 feet and 180 total degrees of bend. (Longer lengths may be used after review and approval of the physical layout of the product installation by Glendinning Marine Products).

One reason why a short cable to the engine governor is critical has to do with engine synchronization. In order to accurately synchronize one engine to the other, it is necessary to position the governor with an accuracy of less than five thousandths (0.005") of an inch. Any unnecessary bend in the control cable to the governor lever, or using a cable that is longer than necessary, will result in lost motion between the actuator and engine, causing a reduction in synchronization accuracy. This greater length will also increase the difficulty in controlling the engine governor using the mechanical backup system.

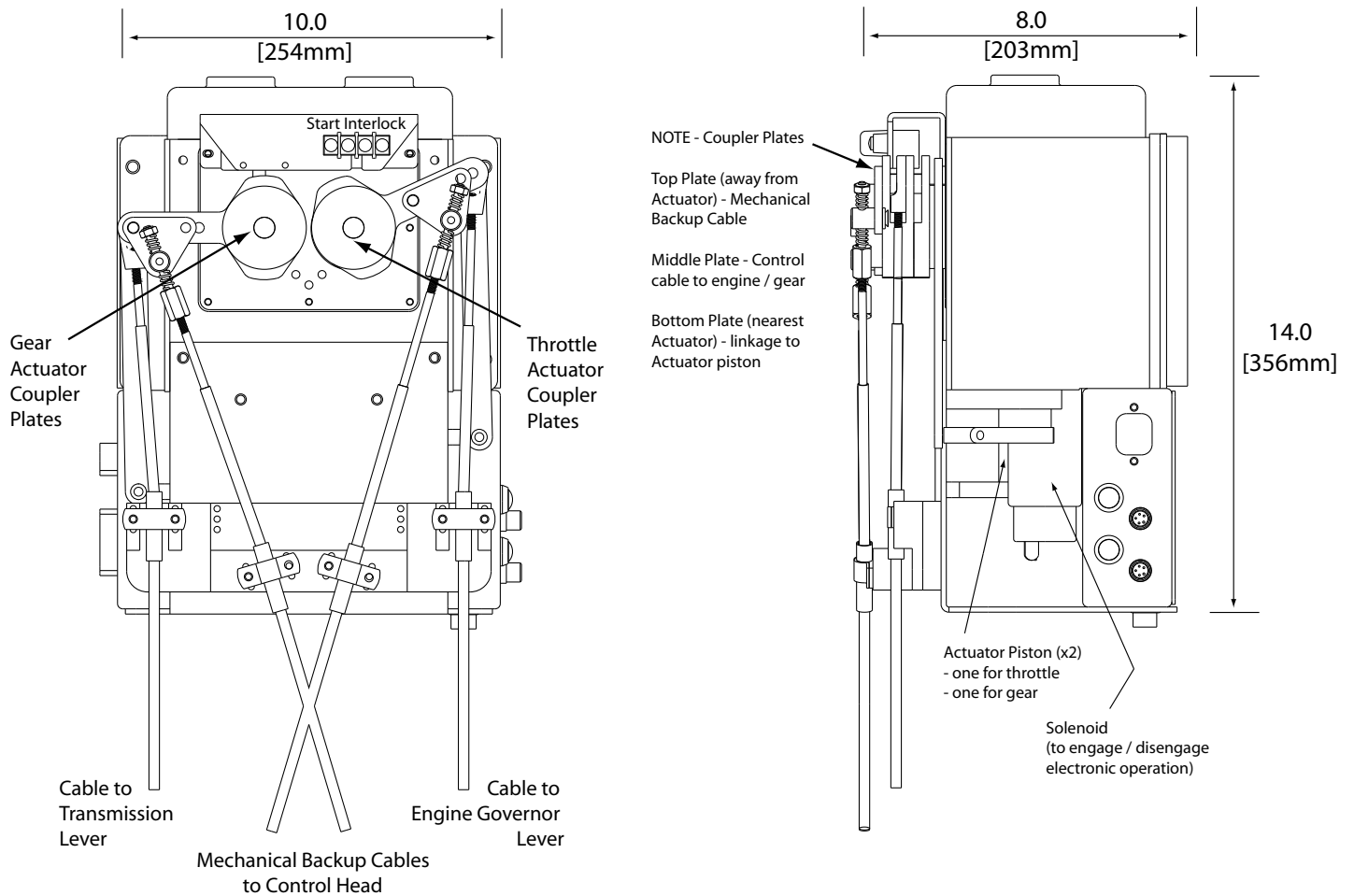
A second important factor which should be considered in correctly positioning the actuators is the routing of the mechanical backup cables. The shortest and most direct routing of the mechanical backup cables is important for smooth and easy operation of the mechanical backup system.

Other factors which should be considered are:

- **The actuators can be mounted in any orientation** — on the bulkhead, overhead, or deck. The actuators should NOT be mounted on the engine.
- **Control cable length** — The push-pull cables between Actuator and Engine Throttle or Gear control lever should be no longer than 10 feet (unless installation layout is approved by Glendinning Marine Products).
- **The actuators should be protected from direct exposure to water or excessive heat.** The Glendinning EEC actuator has been carefully designed to withstand exposure to saltwater normally encountered in an engine room and resist the effects of marine corrosion. However, installing the actuator in a location that subjects it to excessive saltwater exposure will cause premature wear and increase the possibility of system failure. Care should be taken to not locate the actuator near engine room vents, stern tube packing glands or other sources of saltwater spray. Shielding the actuator from sources of excessive heat, such as the engine exhaust manifolds, should also be taken into account.
- **Maintainability** — The actuator should be located in a position that is accessible for control cable adjustments.

— Actuator Installation

The actuators should be securely attached to the boat structure. See Section 3.2, Engine Compartment — Mount the Smart Actuator for installation instructions.



— Control Cable Installation



A WORD REGARDING CONTROL CABLES. . .

To ensure good operation of the Engine Control mechanical backup system it is important that good quality control cables be used. Although the EEC system components - Actuators and Mechanical backup control head - are designed to accommodate any standard Type 33 control cable, there are many grades and qualities of control cables available on the market. Like the position of the Actuators described above, the quality of the control cables will have a direct impact on the function of the mechanical backup after the installation is completed. In general, the use of standard quality "Morse Red Jacket" cables (or Teleflex equivalent) is not recommended. Some installers have had acceptable result using "Morse Supreme" cables (or Teleflex equivalent). Our recommendation, based on decades of experience with control cables, is to use Type 95 control cables manufactured by Glendinning Marine Products, Inc. Our testing has found these cables to have consistently the highest efficiency, smoothest operation, and greatest flexibility of any control cable on the market. NW Control cables by Glendinning are available from Glendinning Marine Products, Lewis Marine Supply, or other marine distributors. On aftermarket installations, it is generally not recommended to reuse the existing control cables for the mechanical backup system.



This section describes the installation and connection of the control cables to the engine governor and gear control lever. This connection must be properly made before control cables are connected to the Smart Actuators.



DO NOT CONNECT MECHANICAL BACKUP CABLES to the Actuator Coupler Plates at this time, however, you may attach mechanical backup cables to their appropriate mounting locations. The best time to connect the mechanical backup cables to the Actuator Coupler Plates is at the completion of Actuator calibration — Section 4.0

1) Using standard Type 33C cable clamps and shims, mount the throttle / gear / troll lever control cables in their respective locations on the engine and transmission. Mount cables using cable clamps only — **DO NOT CONNECT THE CABLE ENDS TO THE CONTROL LEVERS AT THIS TIME.**

2) Install terminal eyes on the end of each control cable, ensuring that the tip of the cable protrudes from the threaded portion of the metal terminal eye or that you have at least 1/2" (13 mm) of thread engagement. Do not tighten the terminal eye locknuts yet.

3) Compare the travel of each control cable to its associated lever at the transmission and engine. Ensure that each control cable has "over-travel" or that the cable is able to travel farther than the lever that it will be attached to. Check this for both ends of travel. If the control cable will not "over-travel" in both directions, adjustments will have to be made:

- If 1/4" or less adjustment is required, the terminal eye on the end of the cable may be screwed on or off the cable end. **Terminal eye thread engagement on the control cable end must never be less than 1/4".**
- If more than 1/4" inch adjustment is necessary to achieve correct over-travel, the cable clamp position on the engine or transmission will have to be moved.



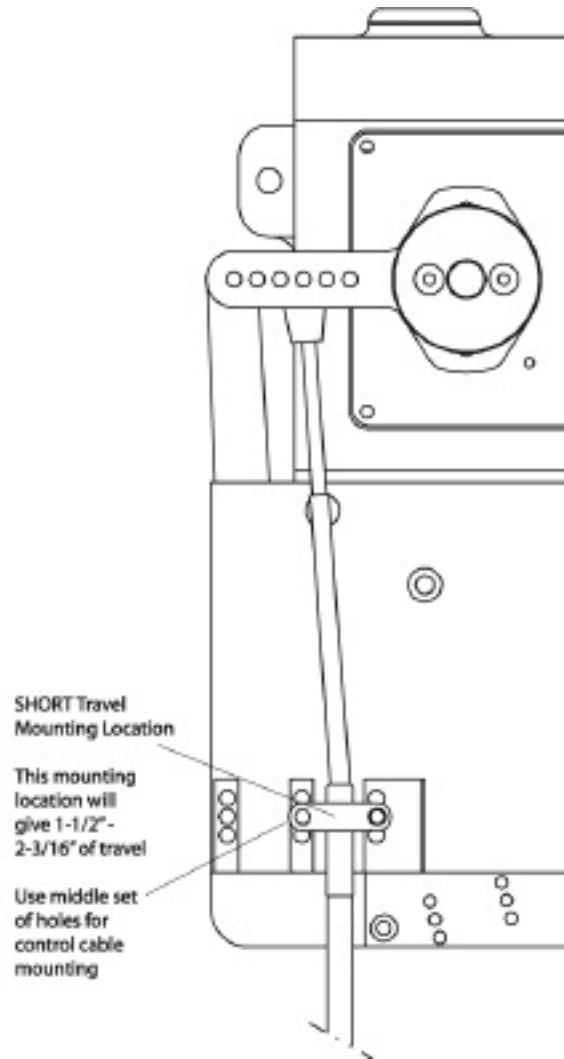
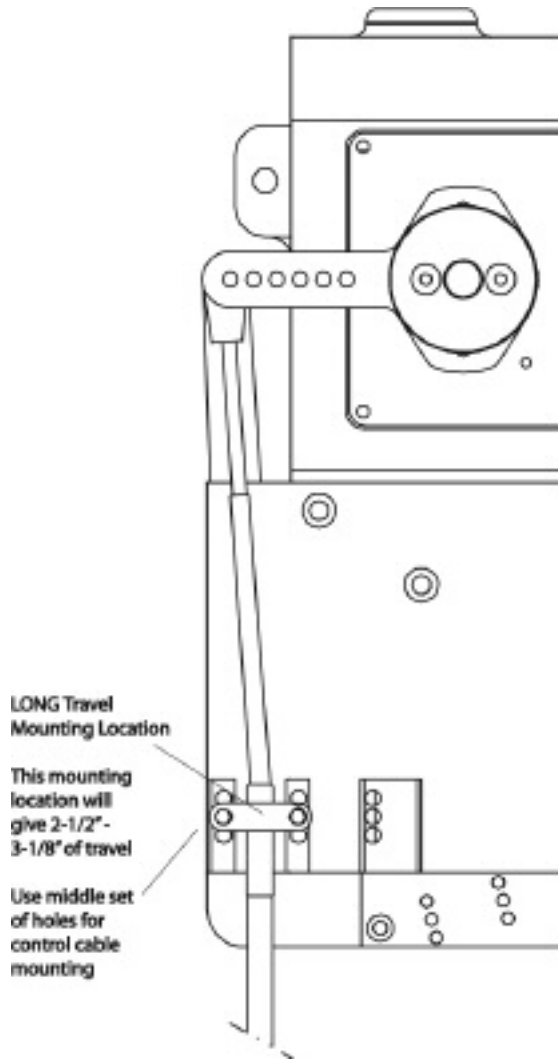
In some cases, sufficient over-travel will not be able to be obtained even with adjustment of the cable clamp holder. This is caused by the connection point on the engine or transmission lever (normally called the pivot pin) being too far away from the shaft that the lever is connected to. In these cases, the pivot pin will have to be moved closer to the shaft (the "fulcrum point") in order to shorten the pivot pin travel. This will give you the correct over-travel required. The recommended length of travel of the control lever pivot pin should be approximately 2 1/2" to 2-3/4".

Once correct control cable over-travel is verified, connect the cable end fitting of each control cable to the engine governor / throttle and transmission lever. **Tighten the control cable terminal eye jam nuts.**

4) After the control cable end fittings are attached to the control levers on the engine governor and transmission, measure the amount of travel for each control cable. Do this measurement at the actuator end of the control cable. (This is the distance that the cable will travel when the engine or transmission control lever is moved from one mechanical stop to the other. Record the information below - this information is needed in order to determine the correct cable connection on the Actuator coupler plates.

PORT ENGINE		STARBOARD ENGINE	
CONTROL CABLE	LENGTH OF TRAVEL	CONTROL CABLE	LENGTH OF TRAVEL
Throttle		Throttle	
Gear		Gear	
Troll Valve		Troll Valve	

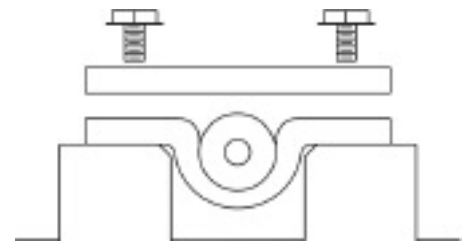
5)



Mount the engine / transmission control cables to the proper control cable mounting location on the actuator. There are two possible mounting locations on the actuator for the control cables depending on the length of control cable travel - the distance measured in Step 4. above. For control cable travel between 1-1/2" and 2-3/16", mount the control cable in the SHORT Travel Mounting location. For control cable travel between 2-1/4" and 3-1/8", mount the control cable in the LONG Travel Mounting location. (See the above drawing for clarification). Use the middle set of holes in each mounting location slot to mount the cable.

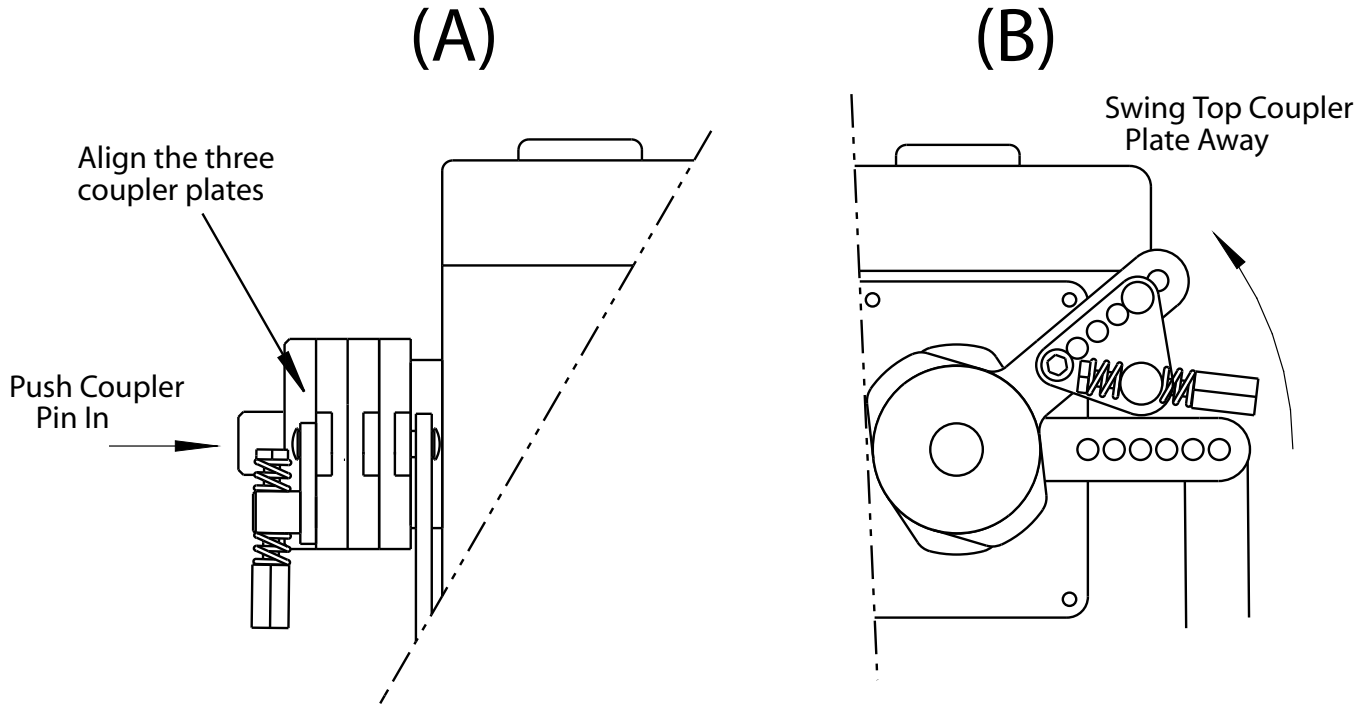


Mount the cables using the cable clamp, cable shim and screws provided. **The cable clamp must be mounted underneath the control cable and then the flat shim is placed on top.** The cable clamps (33c or 43c) will fit in the slots on the actuator.



6) Swing top coupler plate out of way to expose middle coupler plate.

For the engine / transmission control cables, use the middle set of plates on the actuator coupler assembly. To gain access to the middle plates, line up all three (3) plates (drawing A on next page) and then push in on the round coupler pin in the middle of the coupler assembly. This will release the top plate, which can then be swung out of the way (drawing B on the next page). (This top coupler plate is for the mechanical backup cables, which will be used later on in the installation).



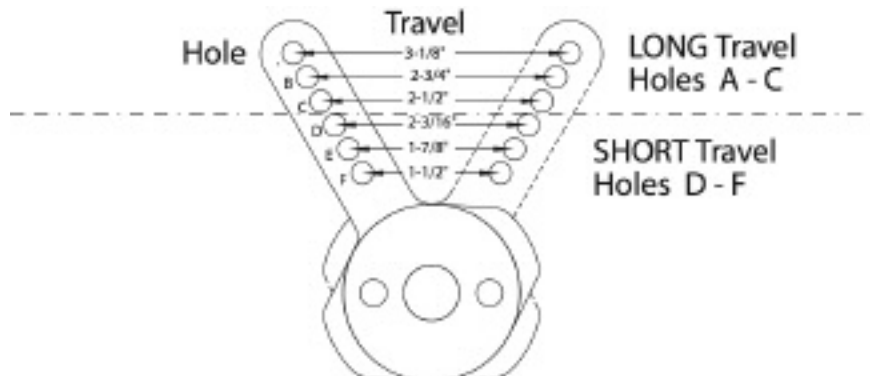
7) Select correct mounting hole for control cable terminal eye.

For each mounting position (long travel or short travel) there are three different terminal eye mounting holes that can be used. The diagram below shows each hole (marked A - F) and the corresponding control cable travel that it will give you. (The control cable travel is the distance that the engine / transmission control cable will move after it is connected to the engine / transmission control lever; this distance was measured in step 4 above). Use the mounting hole that will give you slightly more than the amount of travel recorded in step 4.



Do not connect the control cable to the Actuator coupler plate in this step - see Step 1 for instructions regarding terminal eye adjustment first. This paragraph describes how to determine the correct mounting hole for the control cable mounting hole.

Example: You measured the travel of the control cable at the actuator end and found it to be **2 5/8"**. The cable must be mounted in the **Long Travel Mounting Location** and the cable terminal eye would be **attached to Hole B**. Control cable mounting location must correspond with selected coupler plate travel hole.



TRANSMISSION CONTROL LEVER - CONTROL CABLE TERMINAL EYE ADJUSTMENTS:

The following definitions are commonly used in the marine industry to define control cable movement. Control cable movement is defined by observing the control cable connection at the engine or transmission and determining what is done to the engine or transmission control lever, as follows:

Pull to Open - Control cable “pulls” on the engine governor / throttle to increase RPM.

Push to Open - Control cable “pushes” on the engine governor / throttle to increase RPM.

Pull to Ahead- Control cable “pulls” on the transmission control lever to place transmission in Ahead position.

Push to Ahead - Control cable “pushes” on the transmission control lever to place transmission in Ahead position.

Pull to “Lockup” - Control cable “pulls” on the transmission troll valve control lever to close troll valve (“Full Lockup” - no slip - position).

Push to “Lockup” - Control cable “pushes” on the transmission troll valve control lever to close troll valve (“Full Lockup” - no slip - position).

A) After the control cable is clamped in its proper mounting location on the Actuator (step 5) and the proper coupler plate hole position is determined (step 7), move the transmission control cable so that the transmission control lever is in the neutral position.

B) Adjust the terminal eye so that when the cable travel is in the middle of its backlash, the hole in the terminal eye lines up with the proper hole location on the coupler plate.

YOU ARE NOW READY TO ENTER SMART ACTUATOR CALIBRATION (see Section 4.0).

C) Once adjusted, use the special shoulder bolts provided to mount the cable to the actuator lever. (Use a little grease on the shoulder of the screw. This will help with the feel of the mechanical backup system.)



Terminal eye thread engagement on the cable must be at least $\frac{1}{4}$ ". If a large adjustment is necessary in the terminal eye position (more than $\frac{1}{4}$ "), move the control cable clamp to a different set of holes in its mounting location.

8) After completion of all the control cable mounting and connections, tighten all control cable jam nuts, mounting screws, and shoulder screws. Also, split all cotter pins on engine and transmission control levers.

9) After calibration is complete (see Section 4.0) you may now connect the mechanical backup cables to the Actuator Coupler Plates by following the instructions below:

A) Screw the cable end spring mechanism onto the end of the control cable, obtaining at least $\frac{1}{4}$ " of thread engagement (7 turns).

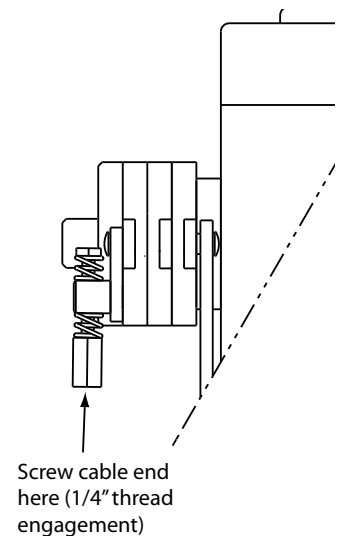
B) Adjust the gear control backup cable as follows:

1 — Verify the following:

- transmission control lever is in the Neutral detent.
- mechanical backup control head is in the Neutral detent.

2 — Compare the relative position of the top coupler plate with the position of the middle and bottom plate. They should all line up at neutral. If not adjust the hex nut.

3 — If hex nut does not have at least $\frac{1}{4}$ " thread engagement then remount the cable in the other set of mounting holes.



C) Attach the throttle control backup cable as follows:

1 — Verify the following:

- governor or throttle is at idle for pull to open and at full open for push to open.
- mechanical backup control head is in the Neutral detent.

2 — Compare the relative position of the top coupler plate with the position of the middle and bottom plate. They should all line up at idle. If not adjust the hex nut.

3 — If hex nut does not have at least 1/4" thread engagement then remount the cable in the other set of mounting holes.

After installation of the mechanical backup cables is completed, verify the following on both engines:

- With the Control Head at Neutral detent, the transmission control lever is at the Neutral detent position.
- Move the Control Head to the Ahead idle detent, the transmission control lever should move in the appropriate direction (toward ahead). The engine governor should be at the idle (mechanical stop) position.

—Mechanical Backup Control Head Installation

It is possible to use another manufacturers mechanical control head with the optional mechanical backup feature of the Smart Actuator system. **PLEASE FOLLOW THE MANUFACTURERS INSTRUCTIONS FOR INSTALLATION OF THE MECHANICAL BACKUP CONTROL HEAD THAT YOU PURCHASED.**

When connecting the mechanical backup control cables to the mechanical backup control head it is **IMPORTANT** to remember:

- Because of the parallel connection of cables at the actuators the operation of the cable at the Control Head will appear to be opposite of the calibrated cable direction (see Section 4.0). For example: If the movement of the throttle lever is Pull-to-Open at it's engine connection — it will appear to be Push-to-Open at the Control Head connection.

When connection of the mechanical backup control cables at the Control Head is complete, tighten all control cable jam nuts, mounting screws, and shoulder screws and verify that you have split all cotter pins on engine and transmission control levers.

D. Installation Checkouts

Once the system has been installed it must be checked for proper operation. the basic checks are as follows:

1) Installation Verification

2) Mechanical Backup Operation

Follow the instructions for each section on the following pages:

1) INSTALLATION VERIFICATION

1.1	Verify that Mechanical Backup Actuator is securely fastened to boat structure.
1.2	Verify that control cable to engine throttle and gear control lever are correctly located in the appropriate mounting location based on cable travel.
1.3	<p>Verify tightness of all mechanical cable attachments:</p> <ul style="list-style-type: none"> —Terminal eye shoulder bolts (attach control cable terminal eyes to control levers) —Control cable jam nuts (located below terminal eyes). —Cable clamps (these hold body of control cable to mounting block). —Verify that terminal eyes have less than 1/2" of threads visible below jam nut. <p>NOTE: It is recommended that the mechanical backup cables not be connected to the actuator at this point. They will be completed after the system is calibrated.</p>
1.4	<p>Mechanical backup control head only — verify tightness of all mechanical cable attachments:</p> <ul style="list-style-type: none"> —Control levers (connected to mechanical backup control head) —Terminal eye shoulder bolts (attach control cable terminal eyes to control levers) —Control cable jam nuts (located below cable end terminal eyes) —Cable clamps (these hold body of control cable to mounting block) —Verify that terminal eyes have less than 1/2" of threads visible below jam nut.
1.5	Mechanical backup control head only — ensure that all mechanical backup cables are free to move through complete range of cable movement (from full throttle ahead to full throttle astern).

2) MECHANICAL BACKUP OPERATION

2.1	With engine OFF, test operate engine control system in Mechanical Backup Mode. Ensure that, while in mechanical control, engine control handle can be moved from Neutral to Ahead gear / full throttle to Astern gear / full throttle to Neutral.
2.2	<p>Test transfer of control from electronic to manual using the following procedure:</p> <ol style="list-style-type: none"> a) Turn ON EEC system and operate electronically. b) Take control at the station equipped for mechanical backup, and advance control handle to the Ahead gear / full throttle position. c) Turn OFF the EEC system. Verify that mechanical operation is regained. d) Repeat steps (a) through (c), for the Reverse gear / full throttle position. e) If the boat is equipped with a second electronic control station (remote station), turn ON the EEC system and take control at the remote station and advance the engine control to the Ahead gear / full throttle position. f) Turn OFF the EEC system. At the station equipped with mechanical backup, move the control handles to the ahead gear / full throttle position. Verify that mechanical operation is regained at the mechanical backup control station. g) Repeat steps (e) through (f), for the Reverse gear / full throttle position.

7.4 Sidemount Controls Installation (optional)

A. Sidemount Handle Control Assembly

Before installing the Sidemount Control Head Assembly consider:

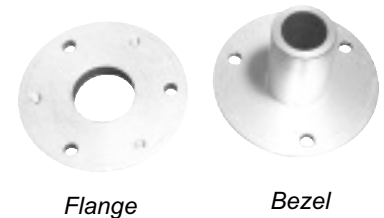
There are 3 types of mounting options for the installation of Sidemount Controls. The major differences between these types of mounting options are the outside appearance of the console, and the difficulty of installation.



Mounting Option	Ease of Installation	Description
Bezel on the Outside of Console	Simple	A bezel and the sidemount control handle are visible on the exterior of the console
Bezel on the Inside of the Console	Hard	Bezel installed on the inside of the console, offers the most professional appearance with the control handle only being seen on the exterior of the console
No Bezel	Difficult	Control Head shaft and handle are visible on the exterior of the console

● Outside Console Bezel Mounting

STEP 1: Determine location of bezel hole in console by placing bezel on outside of console where desired and mark the 1-1/4" hole and the 1/4" clearance holes, (see figure 8) (NOTE: Clearance for control head needs to be determined on inside of console before cutting holes; Make sure to use the correct control head mechanism PORT or STBD when planning the hole locator. Notice location of friction control adjustment screws in respect to console placement!).



Flange

Bezel

STEP 2: Use 1-1/4" hole saw to cut center hole and drill 17/64" holes for outside flange mounting (see figure 9).

STEP 3: Place outside flange in 1-1/4" hole and place inside flange over small diameter of outside flange on inside of console. Tighten flanges together with 1/4" x 20 flat head screws (see figure 10) (NOTE: Depending on console thickness, a small diameter of outside flange and 1/4" x 20 flat head screws may need to be shortened).

STEP 4: Once Outside Flange and Inside Flange are mounted, install (3) #10 flat head wood screws through Inside Flange. This will hold the Inside Flange in place in case of removal in the future (see figure 11) (NOTE: Wood screws should not be longer than the thickness of the console).

STEP 5: Install the Control Head mechanism in flange (see figure 12) (NOTE: The control heads are marked Port and Stb.; Adjustment screws should face forward).

STEP 6: Establish the desired control head angle according to the clearance in the console (see figure 13).

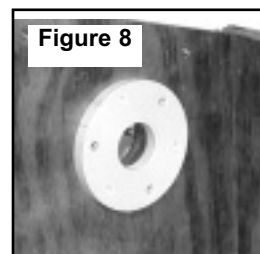


Figure 8

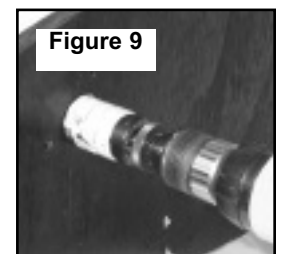


Figure 9

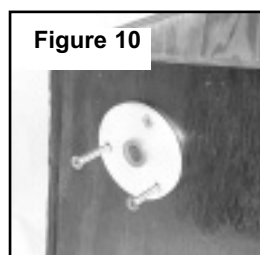


Figure 10

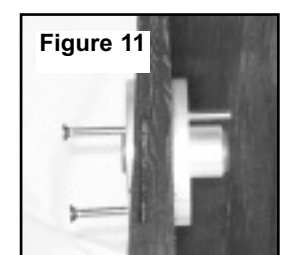


Figure 11

STEP 7: Threaded rod with ball joints are to be attached to head and console at this point (see figure 13) (NOTE: Angle of 90 degrees is best for most support).

STEP 8: Install control handle and key (where applicable) and tighten set screw down to mark shaft. Fine alignment of handles may be adjusted by shortening or lengthening threaded rod (see figure 14) (NOTE: Shaft end play between handle and console should be less than 1/8" [see figure 15]).

STEP 9: Remove set screw and handle and divot shaft using same size drill as the set screw.

STEP 10: Reinstall control handle and use two set screws, on top of each other.

● Inside Console Bezel Mounting

STEP 1: To determine location of inside bezel mount, caution should be exercised to ensure proper placement of bezel prior to cutting hole in the console (NOTE: This is determined by the clearance of the control head on the inside of the console).

STEP 2: Using the "inner bezel" as a template, trace the 1-1/4" center hole onto the inside wall of the console (see figure 16).

STEP 3: Cut out the 1-1/4" center hole and drill (3) #10 starter holes being careful NOT to drill through the wall of the console.

STEP 4: Place inner bezel onto the outer bezel shaft and insert assembly into the 1-1/4" cutout hole. Tighten (3) #10 wood screws into flange where indicated (see figure 17) (NOTE: make sure to use screw lengths that DO NOT exceed the thickness of the console).

STEP 5: Bezel outside of console can now be marked flush so the excess can be removed. This allows no bezel to be seen on outside of console. Remove bezel from console. Remove red bushing from inside of bezel and trim bezel.

STEP 6: Reinstall red bushing in bezel and insert bezel into hole in console. Tighten (3) #10 wood screws into flange where indicated (see figure 18) (NOTE: make sure to use screw lengths that DO NOT exceed the thickness of the console).

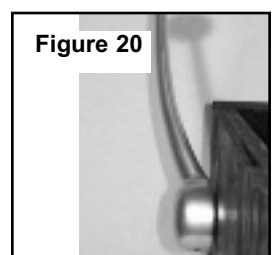
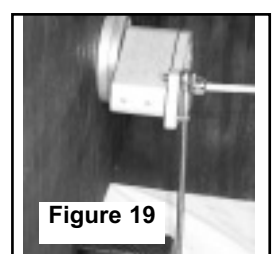
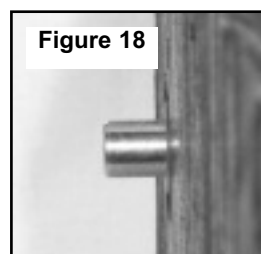
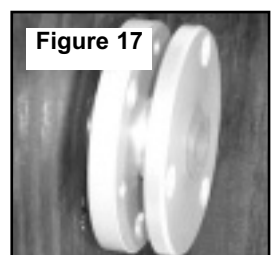
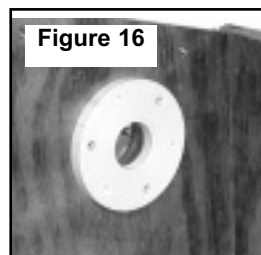
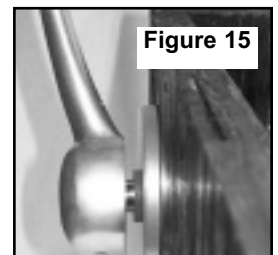
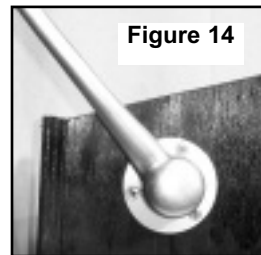
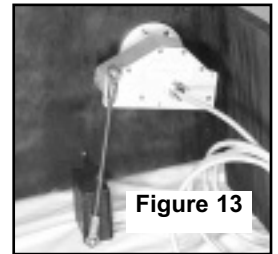
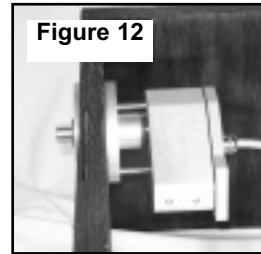
STEP 7: Install the control head shaft into the flange assembly.

STEP 8: Establish the desired control head angle according to the clearance in the console.

STEP 9: Threaded rod with ball joints are to be attached to head and console at this point (NOTE: Angle of 90 degrees is best for most support) (see figure 19).

STEP 10: Install control handle and key (where applicable) and tighten set screw down to mark shaft. Fine alignment of handles may be adjusted by shortening or lengthening threaded rod (NOTE: Shaft end play between handle and console should be less than 1/8") (see figure 20).

STEP 11: Remove set screw and handle and divot shaft using same size drill as the set screw.



STEP 12: Reinstall control handle and use two set screws, on top of each other.

To mount control handles without Bezel mounting kit:

STEP 1: The control head has one face opposite handle shaft with 1/4 threaded holes to mount to inside face of console.

STEP 2: The 1/4 threaded holes can also be used to mount the control head to a bracket of your design, to attach head to some other locations in console.

STEP 3: When method of mounting is determined, keep a these things in mind—The length of shaft outside of console and the free movement of the shaft.

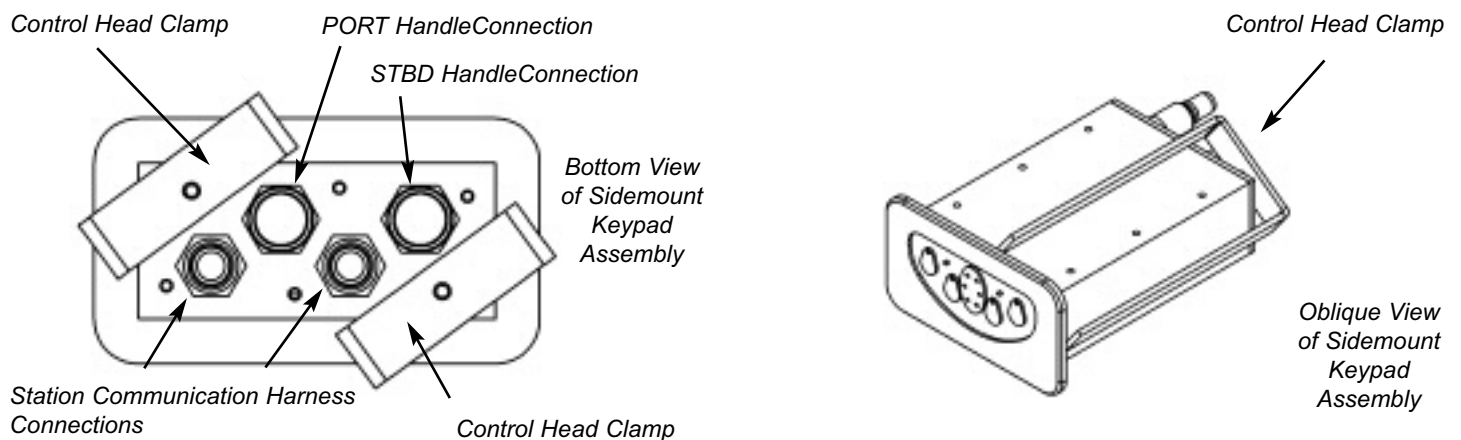
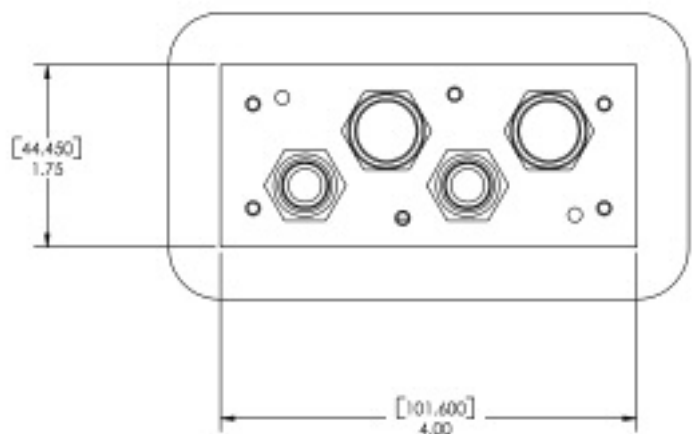
B. Sidemount Keypad Assembly

Before mounting the Sidemount Keypad Assembly, inspect the surface that the Keypad is to be mounted to. It should be flat and reasonably strong enough to support the Keypad securely.

STEP 1: Mark the location for the Keypad Assembly using the full size template (see page 59). Cut the 1-3/4" x 4" keypad assembly cutout.

STEP 2: Insert the connection cable from the Sidemount Control Handle pod and the Station Cable (that leads to the Control Processor) through the console cutout and attach to the keypad assembly. The control head pods are marked PORT and STBD and must be installed in the proper connector.

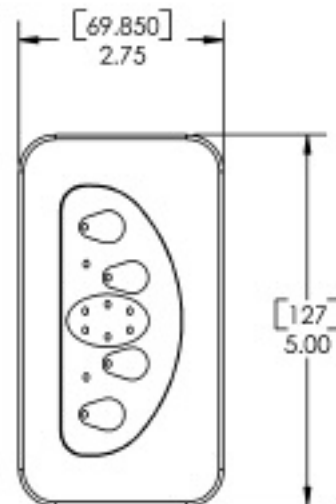
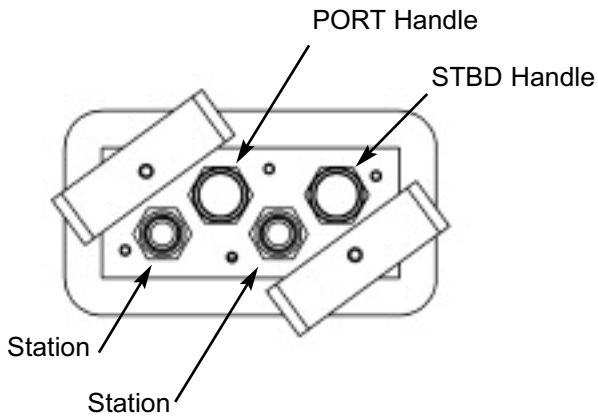
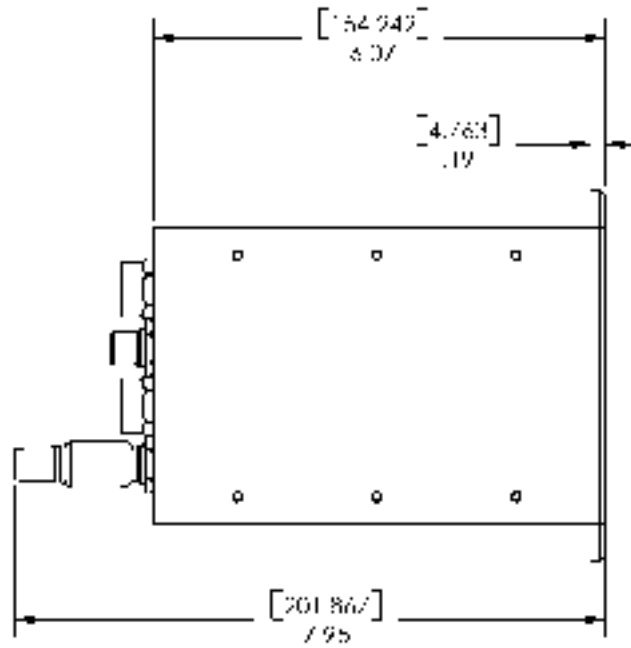
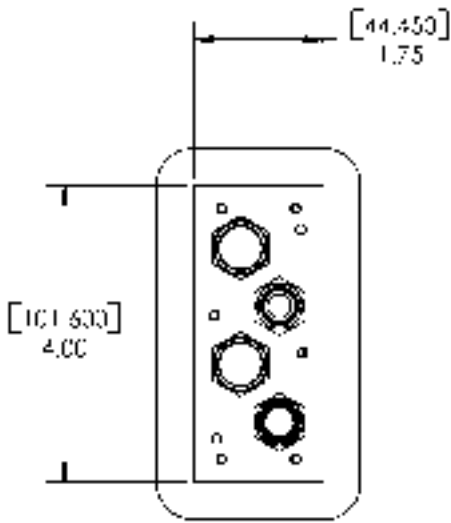
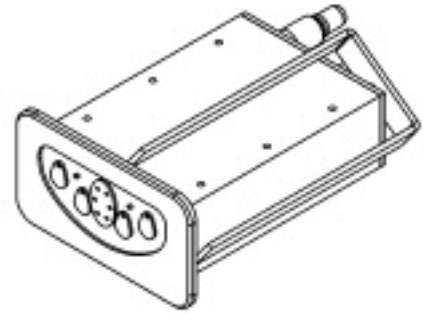
STEP 3: Install Control Head clamps and tighten wing nuts provided. Make sure Keypad Assembly is firmly mounted to console.



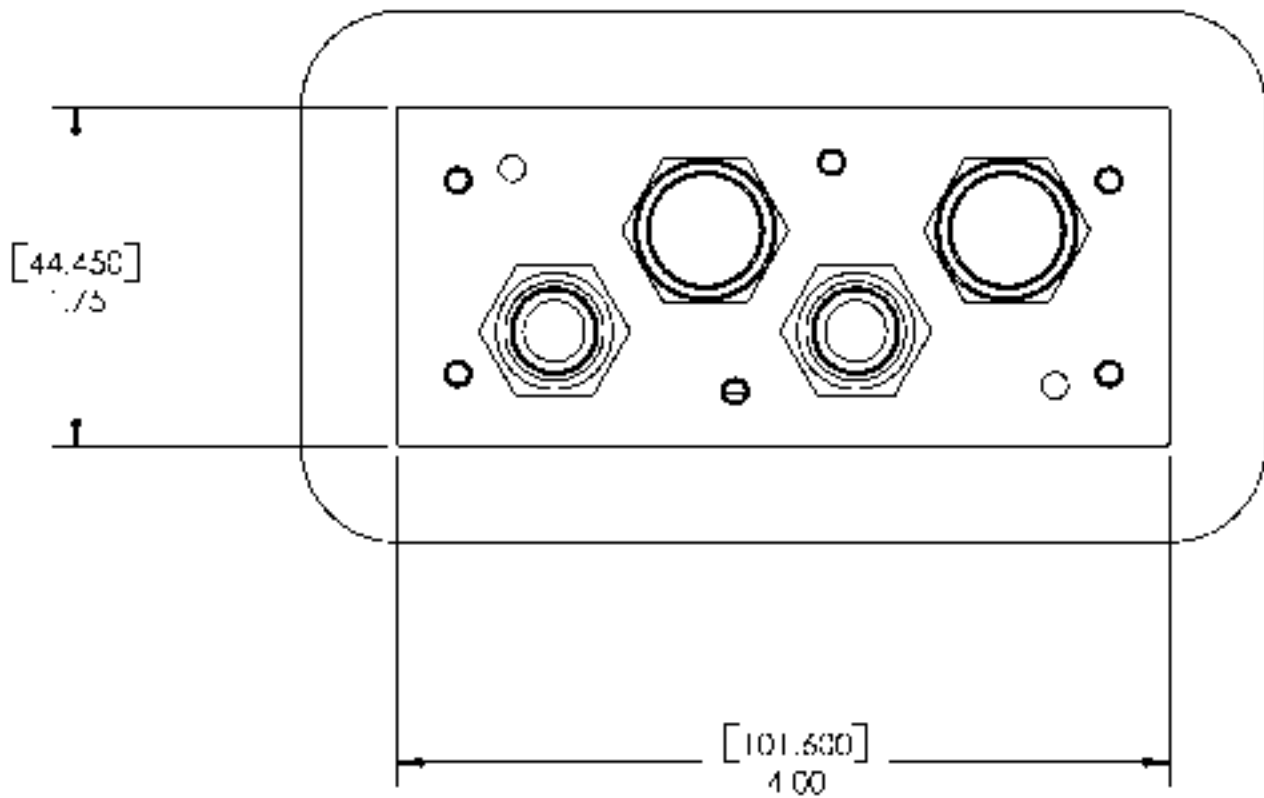
STEP 4: Connect the Sidemount Control Head Assembly (PORT and STBD) to the Sidemount Keypad Assembly at the PORT Handle and STBD Handle Connections (see diagram above). Connect the Station Communication Harness from the Control Processor to the Station Communication Connections on the Keypad Assembly (see diagram above). Depending on your network's configuration a Station Communication Harness or a Terminating Resistor must be installed at both Station Communication Connections on the Keypad Assembly.

Sidemount Keypad Assembly Dimensions

EEC3 SIDEMOUNT KEYPAD ASSEMBLY



Cutout Template for Sidemount Keypad Assembly



7.5 Control Head Configuration (Setting Control Handle ID's)

In order for each Control Head to communicate with the Control Processor, each Control Head must have a unique Handle Identifier. If you purchased a complete system, configuration and handle identification was performed by the factory.

If you purchased a control head **separately**, you will **NEED** to set the handle identifier for that control station. Follow the 8 steps below:

To Change Handle Identifier, Follow These 8 Steps:

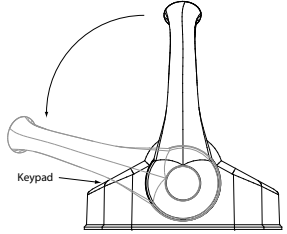
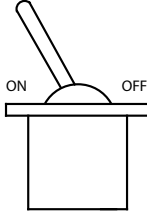

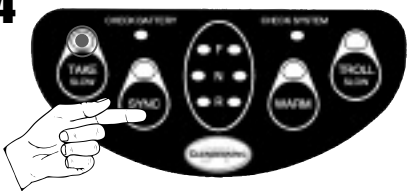
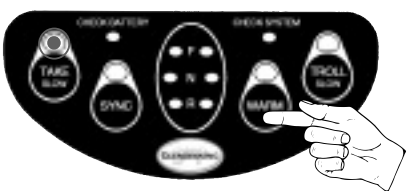
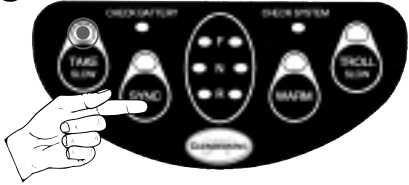
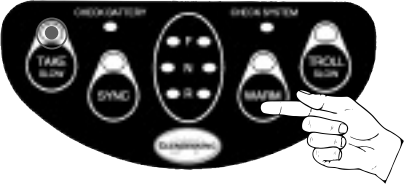
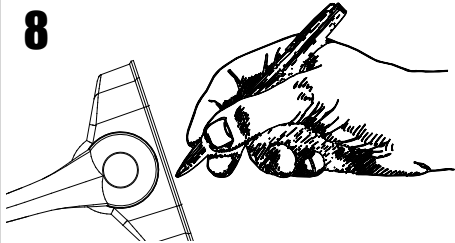
1	ACTION	RESULT
	<p>Move control station handles to FULL ASTERN positions</p>	<p>No result</p>
	<p>Turn power ON to the system</p>	<p>TAKE LED will begin to flash</p>
	<p>Press & HOLD the 2 center buttons (SYNC & WARM) for approximately 2 seconds until all 4 LEDs begin to flash-RELEASE buttons</p>	<p>All 4 LEDs begin to flash</p>
	<p>Press & Release the SYNC button one time to select Handle Identifier Mode</p>	<p>TAKE LED will begin to flash</p>
	<p>Press & Release the WARM button one time to enter Handle ID Configuration</p>	<p>TAKE LED will be illuminated</p>

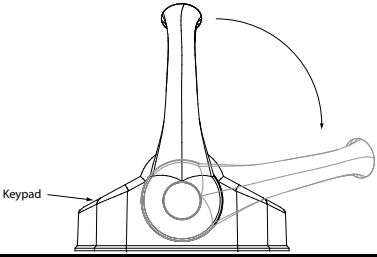
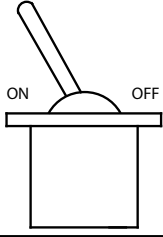


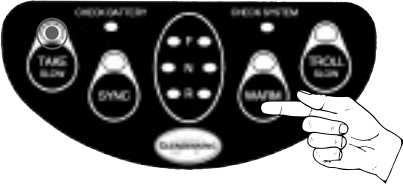
Chart is continued on next page . . .

<p>6</p> 	<p>ACTION</p> <p><i>Press & Release SYNC button until desired handle ID is achieved — see chart at right for ID# and corresponding LED that is illuminated</i></p>	RESULT	
		ID#	LEDs ON
		1	TAKE
		2	SYNC
		3	TAKE & SYNC
		4	WARM
		5	TAKE & WARM
6	SYNC & WARM		
<p>7</p> 	<p><i>Press & Release the WARM button one time</i></p>	<p><i>This action stores your handle ID in memory. All 4 LEDs begin to flash after ID is stored in memory</i></p>	
<p>8</p> 	<p><i>RECORD the Handle ID# on the tag located on the bottom of the Control Head</i></p>	<p>N/A</p>	
<p><i>To Exit Control Handle Configuration Mode — turn system OFF and return control handles to NEUTRAL position.</i></p>			

7.6 Control Processor Configuration

Configuration of the Smart Actuator™ system was performed at GMP from the information the ship operator gave at the time the order was placed. Changes to the Control Processor configuration, although not frequently done, can be made to suit operator preference and is entered from the **control head keypad**. Follow the instructions for each option when making changes.

To Enter System Configuration Mode, follow these steps:

	ACTION	RESULT
	<p>Move control station handles to FULL THROTTLE positions</p>	<p>No result</p>
	<p>Turn power ON to the system</p>	<p>TAKE LED will begin to flash</p>
	<p>Press & Release the WARM button 3 times</p>	<p>All 4 LEDs begin to flash</p>
	<p>Press & Release the SYNC button the number of times as outlined on pages 22-32 for particular System Configuration Option you wish to change</p>	<p>Appropriate LED will be illuminated (see pages 82-93 for LED illumination)</p> <ul style="list-style-type: none"> Actuator Optionspg. 82 Throttle on Top of Troll Optionspg. 83 Troll Delay Optionspg. 84 Throttle Delay Optionspg. 85 Gear Delay Optionspg. 86 High-Idle Step Size Options, PT 1pg. 87 High-Idle Step Size Options, PT 2pg. 88 SystemStartup Mode Optionspg. 89 Station Transfer Optionspg. 90 Set Configuration Settings to Defaultpg. 91 Sync Gain Optionspg.92 Mechanical Backup Optionspg.93
	<p>Press & Release the WARM button one time to save your configuration changes in memory</p>	<p>Appropriate LED will be illuminated depending on which System Configuration Option you selected in Step 4 above.</p>

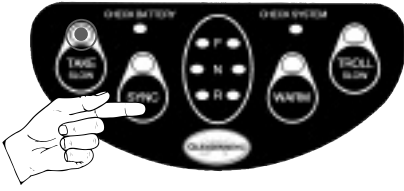

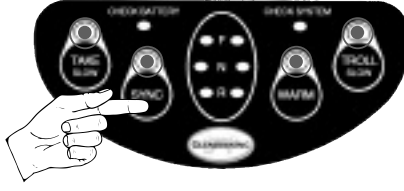

7.6.1 Actuator Options

The Actuator Option allows you to select which actuator configuration your boat is equipped with:

<p>For boats equipped with Mechanical Throttle & Mechanical Gear use Option 1 below (default)</p>	<p>For boats equipped with Mechanical Throttle Mechanical Gear & Mechanical Troll use Option 2 below</p>	<p>For boats equipped with Mechanical Throttle & Electronic Gear use Option 3 below</p>	<p>For boats equipped with Mechanical Throttle Electronic Gear & Mechanical Troll use Option 4 below</p>
--	---	--	---

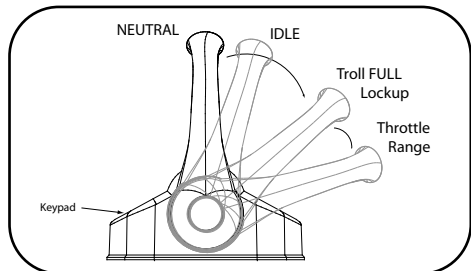
Actuator Option default is set for Mechanical Throttle & Mechanical Gear unless you specified troll option at time of placing order with GMP— if your boat is equipped with trolling vavles and you forgot to inform us, you will need to change this configuration option

To Change Actuator Option Setting Follow These Steps:

Enter Configuration Mode as described in section 5.0 (pg. 85)																							
	ACTION	RESULT																					
	<p>Press & Release SYNC button 1 time for Actuator Options</p>	<p>TAKE LED will begin to flash</p>																					
	<p>Press & Release WARM button 1 time to activate selection</p>	<p>NO LEDs will be illuminated</p> <table border="1" style="width: 100%; border-collapse: collapse;"> <thead> <tr> <th style="width: 5%;"></th> <th style="width: 35%;">LEDs ON</th> <th style="width: 60%;">ACTUATOR OPTION</th> </tr> </thead> <tbody> <tr> <td style="text-align: center;">1</td> <td style="text-align: center;">TAKE</td> <td>Mechanical Throttle Mechanical Gear (default)</td> </tr> <tr> <td style="text-align: center;">2</td> <td style="text-align: center;">SYNC</td> <td>Mechanical Throttle Mechanical Gear Mechanical Troll</td> </tr> <tr> <td style="text-align: center;">3</td> <td style="text-align: center;">TAKE & SYNC</td> <td>Mechanical Throttle Electronic Gear</td> </tr> <tr> <td style="text-align: center;">4</td> <td style="text-align: center;">WARM</td> <td>Mechanical Throttle Electronic Gear Mechanical Troll</td> </tr> <tr> <td style="text-align: center;">5</td> <td style="text-align: center;">TAKE & WARM</td> <td>3-ENGINE Mechanical Throttle & Gear Center follows STBD</td> </tr> <tr> <td style="text-align: center;">6</td> <td style="text-align: center;">SYNC & WARM</td> <td>3-ENGINE Mechanical Throttle & Gear Center follows PORT</td> </tr> </tbody> </table>		LEDs ON	ACTUATOR OPTION	1	TAKE	Mechanical Throttle Mechanical Gear (default)	2	SYNC	Mechanical Throttle Mechanical Gear Mechanical Troll	3	TAKE & SYNC	Mechanical Throttle Electronic Gear	4	WARM	Mechanical Throttle Electronic Gear Mechanical Troll	5	TAKE & WARM	3-ENGINE Mechanical Throttle & Gear Center follows STBD	6	SYNC & WARM	3-ENGINE Mechanical Throttle & Gear Center follows PORT
	LEDs ON	ACTUATOR OPTION																					
1	TAKE	Mechanical Throttle Mechanical Gear (default)																					
2	SYNC	Mechanical Throttle Mechanical Gear Mechanical Troll																					
3	TAKE & SYNC	Mechanical Throttle Electronic Gear																					
4	WARM	Mechanical Throttle Electronic Gear Mechanical Troll																					
5	TAKE & WARM	3-ENGINE Mechanical Throttle & Gear Center follows STBD																					
6	SYNC & WARM	3-ENGINE Mechanical Throttle & Gear Center follows PORT																					
	<p>Press & Release SYNC button repeatedly to cycle through Actuator Options, LED will illuminate according to selection chosen (see chart at right)</p>	<p>(This row is covered by the table in the previous row)</p>																					
	<p>Press & Release WARM button 1 time to save option selection in memory</p>	<p>Once selection has been saved by pressing & releasing the WARM button, you may:</p> <ol style="list-style-type: none"> 1) continue to change other configuration options on the following pages OR . . . 2) you may EXIT CONFIGURATION MODE by turning system OFF, moving control handles back to NEUTRAL, and then turn system ON again. 																					

7.6.2 Throttle on Top of Troll Options

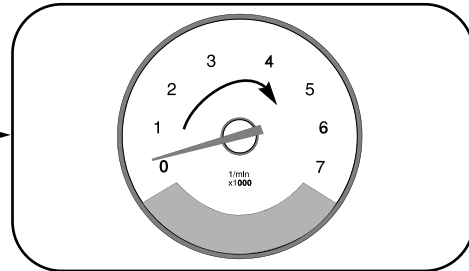
The Throttle on Top of Troll Option allows you to configure the Smart Actuator™ system to give approximately 1/3 of throttle range after reaching troll full lock-up.



Moving handles past trolling valve full-lockup ...

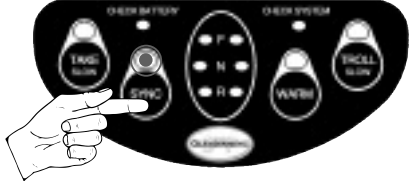
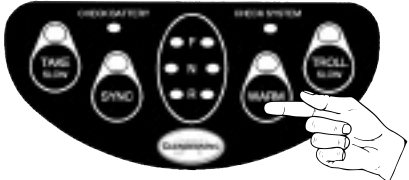
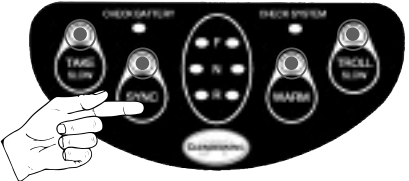
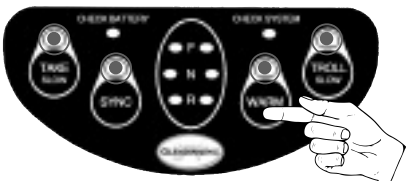
When throttle on top of troll is enabled

(Default = NO throttle on top of troll)



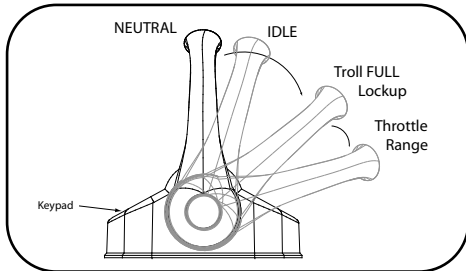
engine RPMs are increased up to 1/3 of normal throttle range

To Change Throttle on Top of Troll Option Setting Follow These Steps:

Enter Configuration Mode as described in section 5.0 (pg. 85)				
ACTION		RESULT		
	Press & Release SYNC button 2 time for Throttle on Top of Troll	SYNC LED will begin to flash		
	Press & Release WARM button 1 time to activate selection	NO LEDs will be illuminated		
	Press & Release SYNC button repeatedly to cycle through Throttle on Top of Troll Options, LED will illuminate according to selection chosen (see chart at right)	1	None	THROTTLE ON TOP OF TROLL OPTION No Throttle on Top of Troll (default)
		2	TAKE	Throttle on Top of FULL Lockup
	Press & Release WARM button 1 time to save option selection in memory	Once selection has been saved by pressing & releasing the WARM button, you may: 1) continue to change other configuration options on the following pages OR . . . 2) you may EXIT CONFIGURATION MODE by turning system OFF, moving control handles back to NEUTRAL, and then turn system ON again.		

7.6.3 Troll Delay Options

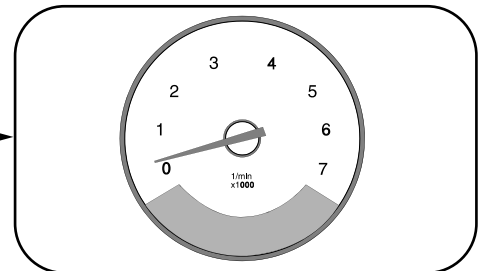
The Troll Delay option allows you to configure the Smart Actuator™ system to delay troll modulation as the system goes from gear shift to troll modulation.



When in Troll Mode, moving handles in or out of the throttle on top of troll range ...

**Configurable
0-2.5 second
Delay**

system will pause ...
(Default = NO delay)



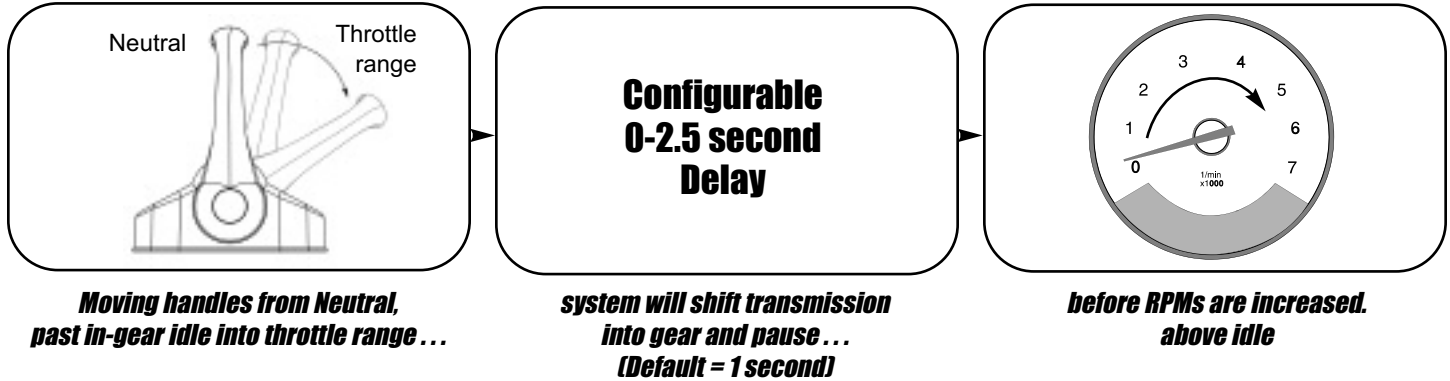
before engaging or disengaging
trolling valves

To Change Troll Delay Option Settings Follow These Steps:

<i>Enter Configuration Mode as described in section 5.0 (pg. 85)</i>				
	ACTION	RESULT		
	Press & Release SYNC button 3 time for Troll Delay Options	TAKE & SYNC LEDs will begin to flash		
	Press & Release WARM button 1 time to activate selection	NO LEDs will be illuminated		
	Press & Release SYNC button repeatedly to cycle through Troll Delay Options, LED will illuminate according to selection chosen (see chart at right)	1	None	No Troll Delay (default)
		2	TAKE	0.5 second delay
		3	SYNC	1.0 second delay
		4	TAKE & SYNC	1.5 second delay
		5	WARM	2.0 second delay
		6	TAKE & WARM	2.5 second delay
	Press & Release WARM button 1 time to save option selection in memory	Once selection has been saved by pressing & releasing the WARM button, you may: 1) continue to change other configuration options on the following pages OR . . . 2) you may EXIT CONFIGURATION MODE by turning system OFF, moving control handles back to NEUTRAL, and then turn system ON again.		

7.6.4 Throttle Delay Options

The Throttle Delay Option allows you to configure the Smart Actuator™ system to delay throttle output as you shift from Neutral, past in-gear idle, and into the throttle range.

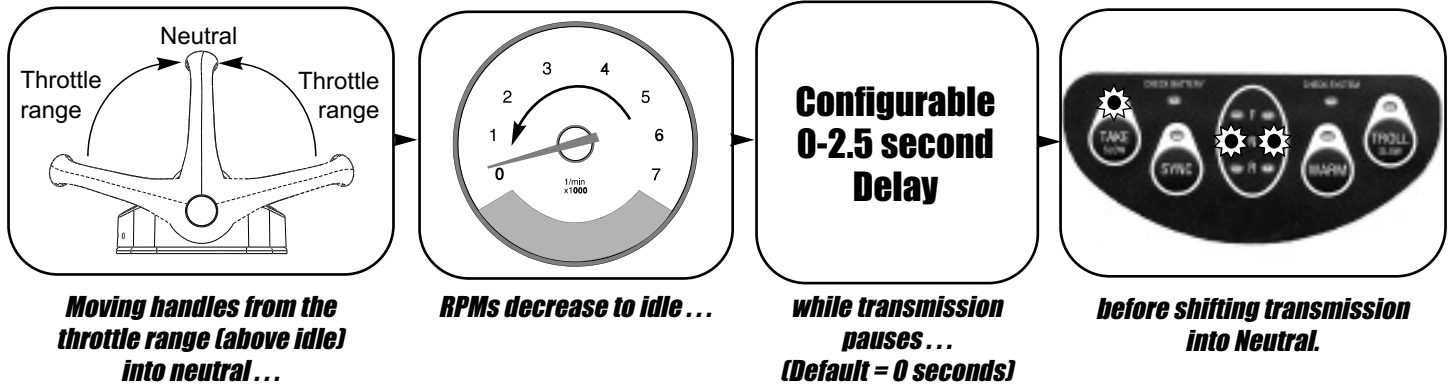


To Change Throttle Delay Setting Follow These Steps:

Enter Configuration Mode as described in section 5.0 (pg. 85)				
ACTION		RESULT		
	Press & Release SYNC button 4 times for Throttle Delay Option	WARM LED will begin to flash		
	Press & Release WARM button 1 time to activate selection	NO LEDs will be illuminated		
	Press & Release SYNC button repeatedly to cycle through Throttle Delay Options, LED will illuminate according to selection chosen (see chart at right)	1	None	None
		2	TAKE	0.5 second
		3	SYNC	1.0 second (Default)
		4	TAKE & SYNC	1.5 second
		5	WARM	2.0 second
		6	TAKE & WARM	2.5 second
	Press & Release WARM button 1 time to save option selection in memory	Once selection has been saved by pressing & releasing the WARM button, you may: 1) continue to change other configuration options on the following pages OR ... 2) you may EXIT CONFIGURATION MODE by turning system OFF, moving control handles back to NEUTRAL, and then turn system ON again.		

7.6.5 Gear Delay Options

The Gear Delay Option allows you to configure the Smart Actuator™ system to remain in gear when the system goes from the throttle range to neutral, to allow throttle to reach idle before shifting transmission.

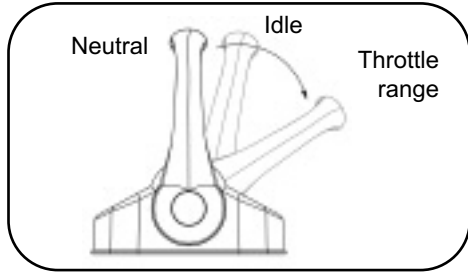


To Change Gear Delay Setting Follow These Steps:

Enter Configuration Mode as described in section 5.0 (pg. 85)				
ACTION		RESULT		
	Press & Release SYNC button 5 times for Gear Delay Option	TAKE & WARM LEDs will begin to flash		
	Press & Release WARM button 1 time to activate selection	NO LEDs will be illuminated		
	Press & Release SYNC button repeatedly to cycle through Gear Delay Options, LED will illuminate according to selection chosen (see chart at right)	1	None	None (Default)
		2	TAKE	0.5 second
		3	SYNC	1.0 second
		4	TAKE & SYNC	1.5 second
		5	WARM	2.0 second
		6	TAKE & WARM	2.5 second
	Press & Release WARM button 1 time to save option selection in memory	Once selection has been saved by pressing & releasing the WARM button, you may: 1) continue to change other configuration options on the following pages OR . . . 2) you may EXIT CONFIGURATION MODE by turning system OFF, moving control handles back to NEUTRAL, and then turn system ON again.		

7.6.6 High-Idle Step Size (Pt. 1) Options

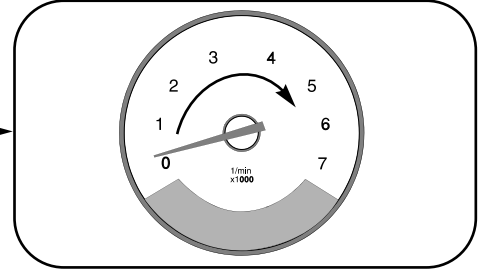
The High-Idle Step Size (Pt. 1) Option allows you to configure the Smart Actuator™ system to increase engine idle speed from .5% to 30% of total throttle output.



While in Neutral or Idle Detent Control Head handle positions ...

Configurable Engine Idle Setting
(see chart below)

(Default = 4% of total throttle output)



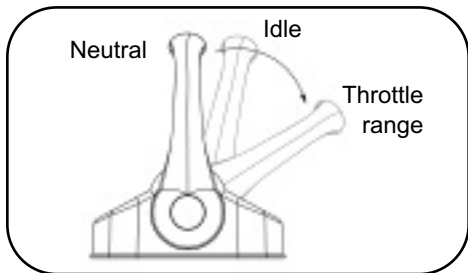
engine idle speed can be increased according to desired setting

To Change High-Idle Step Size Setting Follow These Steps:

Enter Configuration Mode as described in section 5.0 (pg. 85)			
ACTION	RESULT		
<p>Press & Release SYNC button 6 times for High-Idle Step Size, 1</p>	SYNC & WARM LEDs will begin to flash		
<p>Press & Release WARM button 1 time to activate selection</p>	NO LEDs will be illuminated		
<p>Press & Release SYNC button repeatedly to cycle through High Idle Options, LED will illuminate according to selection chosen (see chart at right)</p>			
	1	None	0.5% of Throttle Range
	2	TAKE	1% of Throttle Range
	3	SYNC	2% of Throttle Range
	4	TAKE & SYNC	3% of Throttle Range
	5	WARM	4% of Throttle Range (default)
	6	TAKE & WARM	5% of Throttle Range
	7	SYNC & WARM	10% of Throttle Range
	8	TAKE, SYNC & WARM	20% of Throttle Range
9	TROLL	30% of Throttle Range	
<p>Press & Release WARM button 1 time to save option selection in memory</p>	<p>Once selection has been saved by pressing & releasing the WARM button, you may:</p> <ol style="list-style-type: none"> continue to change other configuration options on the following pages OR . . . you may EXIT CONFIGURATION MODE by turning system OFF, moving control handles back to NEUTRAL, and then turn system ON again. 		

7.6.7 High-Idle Step Size (Pt. 2) Options

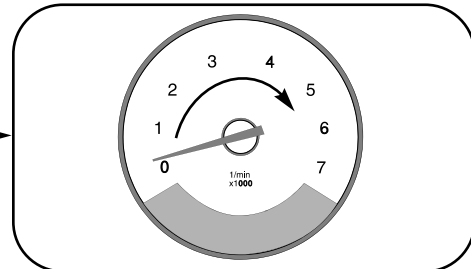
The High-Idle Step Size (Pt. 2) Option allows you to configure the Smart Actuator™ system to change idle speed beyond the High-Idle Step (Pt. 1) Option range (from .5% to 5%).



While in Neutral or Idle Detent Control Head handle positions...

Configurable Engine Idle Setting
(see chart below)

(Default = 2% of total throttle output)



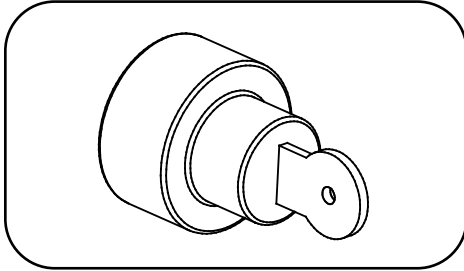
engine idle speed can be increased according to desired setting

To Change High-Idle Step Size Setting Follow These Steps:

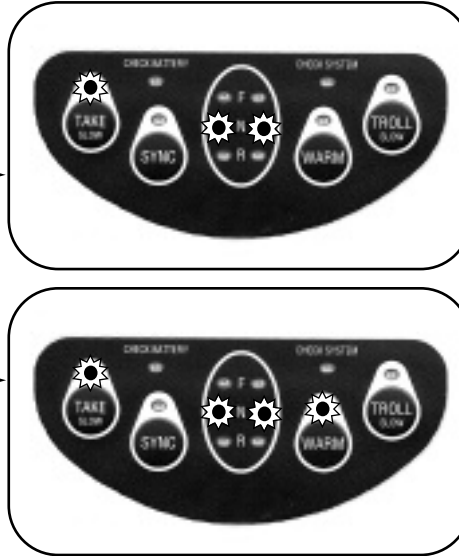
Enter Configuration Mode as described in section 5.0 (pg. 85)				
ACTION		RESULT		
	Press & Release SYNC button 7 times for High-Idle Step Size, 2	TAKE, SYNC & WARM LEDs will begin to flash		
	Press & Release WARM button 1 time to activate selection	NO LEDs will be illuminated		
	Press & Release SYNC button repeatedly to cycle through High Idle Options, LED will illuminate according to selection chosen (see chart at right)	1	None	0.5% of Throttle Range
		2	TAKE	1% of Throttle Range
		3	SYNC	2% of Throttle Range (default)
		4	TAKE & SYNC	3% of Throttle Range
		5	WARM	4% of Throttle Range
		6	TAKE & WARM	5% of Throttle Range
	Press & Release WARM button 1 time to save option selection in memory	Once selection has been saved by pressing & releasing the WARM button, you may: 1) continue to change other configuration options on the following pages OR ... 2) you may EXIT CONFIGURATION MODE by turning system OFF, moving control handles back to NEUTRAL, and then turn system ON again.		

7.6.8 System Startup Options

The System Startup Option allows you to configure the Smart Actuator™ system to enter WARM Mode or Normal RUN Mode at startup (power ON).



When turning system ON...



the transmission will immediately respond to the any movement of the control head handles - normal operation

(Default)

OR

the transmission will be locked in WARM Mode (Neutral position) - RPMs will be increased only

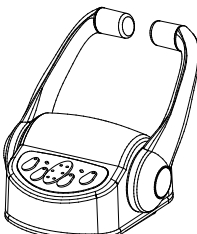
To Change System Startup Setting Follow These Steps:

<i>Enter Configuration Mode as described in section 5.0 (pg. 85)</i>												
		ACTION	RESULT									
		Press & Release SYNC button 8 times for System Startup Option	TROLL LED will begin to flash									
		Press & Release WARM button 1 time to activate selection	NO LEDs will be illuminated									
		Press & Release SYNC button repeatedly to cycle through System Startup Options, LED will illuminate according to selection chosen (see chart at right)	<table border="1" style="width: 100%; border-collapse: collapse;"> <thead> <tr> <th style="width: 10%;"></th> <th style="width: 40%;">LEDs ON</th> <th style="width: 50%;">OPTION</th> </tr> </thead> <tbody> <tr> <td style="text-align: center;">1</td> <td style="text-align: center;">None</td> <td style="text-align: center;">WARM Mode (locked in Neutral)</td> </tr> <tr> <td style="text-align: center;">2</td> <td style="text-align: center;">TAKE</td> <td style="text-align: center;">Normal RUN Mode (Default)</td> </tr> </tbody> </table>		LEDs ON	OPTION	1	None	WARM Mode (locked in Neutral)	2	TAKE	Normal RUN Mode (Default)
	LEDs ON	OPTION										
1	None	WARM Mode (locked in Neutral)										
2	TAKE	Normal RUN Mode (Default)										
		Press & Release WARM button 1 time to save option selection in memory	<p style="text-align: center;">Once selection has been saved by pressing & releasing the WARM button, you may:</p> <p>1) continue to change other configuration options on the following pages OR . . .</p> <p>2) you may EXIT CONFIGURATION MODE by turning system OFF, moving control handles back to NEUTRAL, and then turn system ON again.</p>									

7.6.9 Station Transfer Options

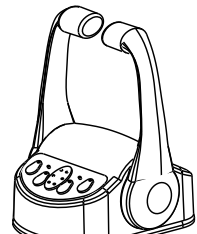
The Station Transfer Option allows you to configure the Smart Actuator™ system to transfer station control underway above idle or with handles at the Neutral position only.

NOTE: Active Station can be at any handle position during station transfer



Inactive Station “taking control” must have control handles at Neutral or in the same gear at same or lower speed as Active Station

OR

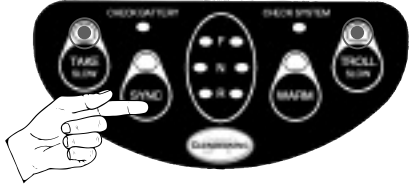
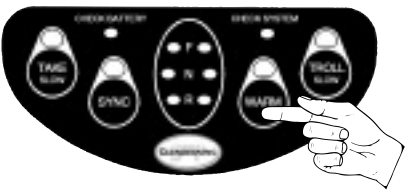
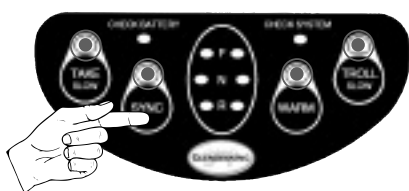
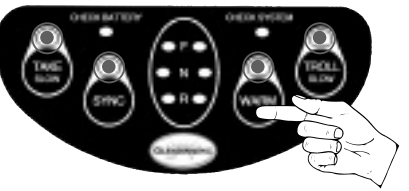


Inactive Station “taking control” must be at Neutral position in order to transfer control from Active Station

Choose “underway transfer” when you want to transfer control when handles are in appropriate position—not limited to Neutral gear only (Default)

Choose “Neutral transfer” when you want to transfer control when handles are in Neutral only

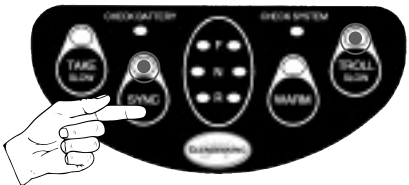

To Change Station Transfer Setting Follow These Steps:

Enter Configuration Mode as described in section 5.0 (pg. 85)								
		ACTION	RESULT					
		Press & Release SYNC button 9 times for Station Transfer Option	TAKE & TROLL LEDs will begin to flash					
		Press & Release WARM button 1 time to activate selection	NO LEDs will be illuminated					
		Press & Release SYNC button to cycle through Station Transfer Options, LEDs will illuminate (see chart at right)	1	<table border="1" style="width: 100%;"> <thead> <tr> <th style="text-align: center;">LEDs ON</th> <th style="text-align: center;">OPTION</th> </tr> </thead> <tbody> <tr> <td style="text-align: center;">None</td> <td style="text-align: center;">Underway Transfer (Default)</td> </tr> </tbody> </table>	LEDs ON	OPTION	None	Underway Transfer (Default)
LEDs ON	OPTION							
None	Underway Transfer (Default)							
		2	<table border="1" style="width: 100%;"> <tbody> <tr> <td style="text-align: center;">TAKE</td> <td style="text-align: center;">Transfer At Neutral Position only</td> </tr> </tbody> </table>	TAKE	Transfer At Neutral Position only			
TAKE	Transfer At Neutral Position only							
		Press & Release WARM button 1 time to save option selection in memory	Once selection has been saved by pressing & releasing the WARM button, you may: <ol style="list-style-type: none"> 1) continue to change other configuration options on the following pages OR . . . 2) you may EXIT CONFIGURATION MODE by turning system OFF, moving control handles back to NEUTRAL, and then turn system ON again. 					

7.6.10 Return System Settings to Default Option

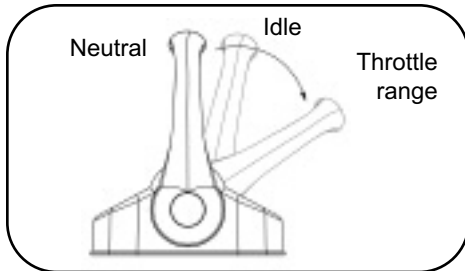
The Return System Settings to Default Option allows you to return the Smart Actuator™ system to it's factory default settings.

To Change System Settings to the Default values, Follow These Steps:

<i>Enter Configuration Mode as described in section 5.0 (pg. 85)</i>		
	ACTION	RESULT
	<i>Press & Release SYNC button 10 times for Return to Default Option</i>	<i>SYNC & TROLL LEDs will begin to flash</i>
	<i>Press & Release WARM button 1 time to save option selection in memory</i>	<i>Once selection has been saved by pressing & releasing the WARM button, you may:</i> 1) <i>continue to change other configuration options on the following pages OR . . .</i> 2) <i>you may EXIT CONFIGURATION MODE by turning system OFF, moving control handles back to NEUTRAL, and then turn system ON again.</i>

7.6.11 Sync Gain Options

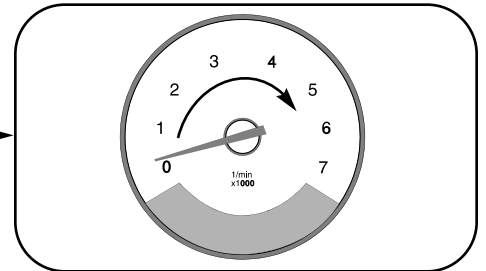
The Sync Gain Option allows you to configure the Smart Actuator™ system to allow the Slave engine to respond quicker when you are in SYNC Mode. The higher the Sync Gain number the quicker the response.



While in SYNC Mode moving the control head handles...

Configurable Sync Gain Setting
(see chart below)

(Default = Sync Gain setting #8)



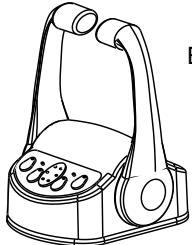
causes the SLAVE engine (normally PORT) to respond quicker to the movement of the control head handles

To Change Sync Gain Setting Follow These Steps:

Enter Configuration Mode as described in section 5.0 (pg. 85)		
	ACTION	RESULT
	Press & Release SYNC button 11 times for Sync Gain Options	TAKE, SYNC & TROLL LEDs will begin to flash
	Press & Release WARM button 1 time to activate selection	NO LEDs will be illuminated
	Press & Release SYNC button repeatedly to cycle through Sync Gain Options, LED will illuminate according to selection chosen (see chart at right)	<p>Sync Gain #1 TAKE LED ON</p> <p>Sync Gain #2 SYNC LED ON</p> <p>Sync Gain #3 TAKE & SYNC LED ON</p> <p>Sync Gain #4 WARM LED ON</p> <p>Sync Gain #5 TAKE & WARM LED ON</p> <p>Sync Gain #6 SYNC & WARM LED ON</p> <p>Sync Gain #7 TAKE, SYNC, & WARM LED ON</p> <p>Sync Gain #8(Default) TROLL LED ON</p> <p>Sync Gain #9 TAKE & TROLL LED ON</p> <p>Sync Gain #10 SYNC & TROLL LED ON</p> <p>Sync Gain #11 TAKE, SYNC, & TROLL LED ON</p> <p>Sync Gain #12 WARM & TROLL LED ON</p> <p>Sync Gain #13 TAKE, WARM, & TROLL LED ON</p> <p>Sync Gain #14 SYNC, WARM, & TROLL LED ON</p> <p>Sync Gain #15 ALL 4 LEDS ON</p>
	Press & Release WARM button 1 time to save option selection in memory	<p>Once selection has been saved by pressing & releasing the WARM button, you may:</p> <p>1) continue to change other configuration options on the following pages OR . . .</p> <p>2) you may EXIT CONFIGURATION MODE by turning system OFF, moving control handles back to NEUTRAL, and then turn system ON again.</p>

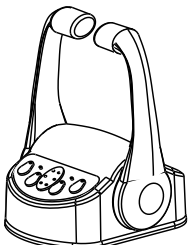
7.6.12 Mechanical Backup Options

The Mechanical Backup Option allows you to configure the Smart Actuator™ system for Mechanical Backup operation if an alarm occurs and renders the normal system inoperable.



Choose “Mechanical Backup ENABLED” if your boat is equipped with the Smart Actuator™ Mechanical Backup option. Mechanical Backup operation is only available from designated control head.

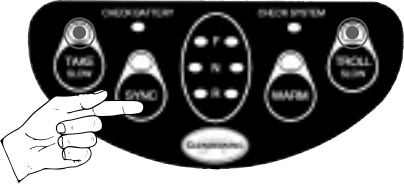
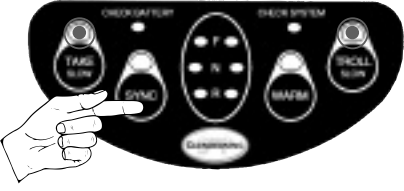



OR



Choose “Mechanical Backup DISABLED” if your boat is NOT equipped for the Smart Actuator™ Mechanical Backup option.

NOTE: If Mechanical Backup Option is enabled, control must be taken at control station designated for mechanical backup operation.

To Change Mechanical Backup Setting Follow These Steps:

		Enter Configuration Mode as described in section 5.0 (pg. 85)			
		ACTION	RESULT		
		Press & Release SYNC button 12 times for Backup Options	WARM & TROLL LEDs will begin to flash		
		Press & Release WARM button 1 time to activate selection	NO LEDs will be illuminated		
		Press & Release SYNC button to cycle through Backup Options, LEDs will illuminate (see chart at right)	1	LEDs ON	BACKUP OPTION
				None	Mechanical Backup DISABLED (Default)
			2	TAKE	Mechanical Backup ENABLED
		Press & Release WARM button 1 time to save option selection in memory	Once selection has been saved by pressing & releasing the WARM button, you may: 1) continue to change other configuration options on the following pages OR . . . 2) you may EXIT CONFIGURATION MODE by turning system OFF, moving control handles back to NEUTRAL, and then turn system ON again.		

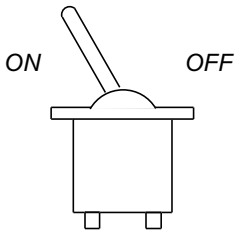
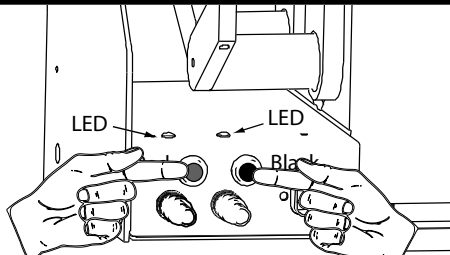
7.7 Smart Actuator Configuration

IF YOU PURCHASED A COMPLETE SYSTEM, ACTUATOR CONFIGURATION WAS PERFORMED AT THE FACTORY. ALL THAT IS NEEDED BY THE INSTALLER IS TO CALIBRATE THE ACTUATOR ENDPOINTS AND CABLE DIRECTION — SEE SECTION 4.0.

If you purchased an Actuator separately, you may need to configure the Smart Actuator by following the procedures below to achieve the desired configuration for your system. The configuration of the Smart Actuator is divided into five sections. Two of the sections, setting actuator cable direction for actuators 1 and 2 have been discussed in detail in Section 4.0. In this section we will discuss the remaining 3, which are:

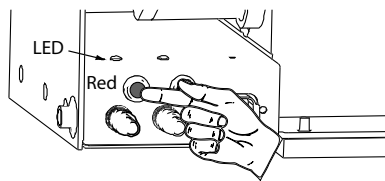
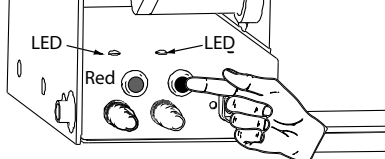
- Setting the Actuator Default Configuration
- Setting the Actuator Identifier
- Setting the Tachometer Pulses / Revolution (PPR)

In order to enter the configuration mode you must follow the steps below:

	<p>ACTION</p> <p>Turn power to Smart Actuators ON</p>	<p>RESULT</p> <p>N/A</p>
	<p>Press & Release in sequence the RED then the BLACK then the RED buttons on the Smart Actuator (you have 5 seconds to complete process)</p>	<p>Both LEDs above the RED and BLACK buttons will flash to indicate that you have entered Smart Actuator Configuration Menu (if the System does NOT enter configuration mode, wait at least 5 seconds and repeat the process)</p>

Once BOTH LEDs are flashing you are ready to proceed by selecting which configuration menu you would like to change. After changing each selection it will be necessary to store that selection in memory (detailed in each section). After storing the selections you have made the system will return to this state — BOTH LEDs flashing — to allow other menus to be selected. This will enable you to make configuration changes without having to leave the configuration mode each time a change is made to a menu.

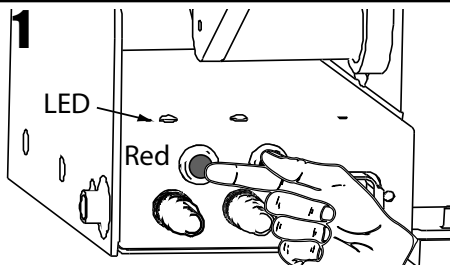
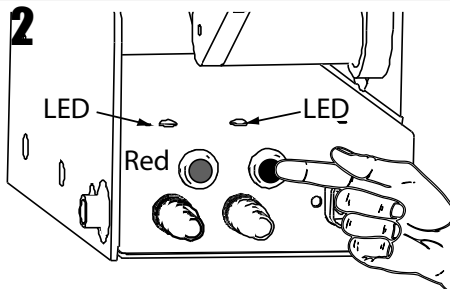
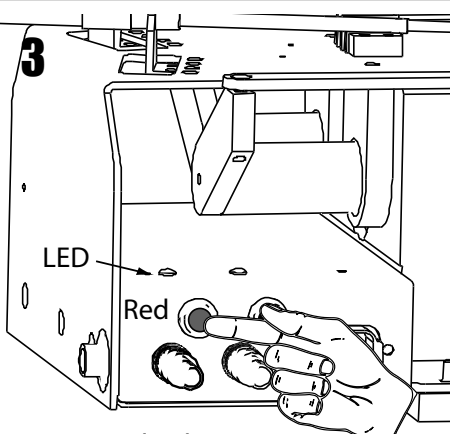
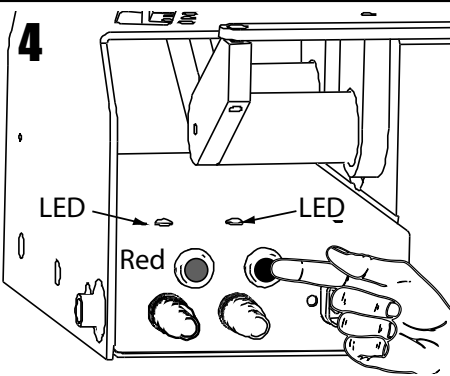
7.7.1 — Setting the Actuator Default Configuration:

<p>1</p> 	<p>ACTION</p> <p>Press & Release the RED button on the Smart Actuator 3 times to select Actuator Default Configuration Menu</p>	<p>RESULT</p> <p>The RED LED will begin to flash 3 times, pause and then repeat.</p>
<p>2</p> 	<p>Press & Release the BLACK button 1 time to store the Actuator Default Settings</p>	<p>This action will return you to the main configuration menu indicated by BOTH LEDs flashing. You may continue to the setting of Actuator Identifier Menu OR you may EXIT Configuration Mode by turning power OFF,</p>

7.7.2 — Setting the Actuator Identifier:

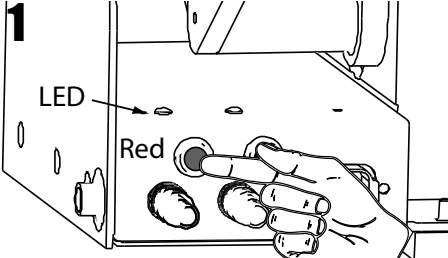
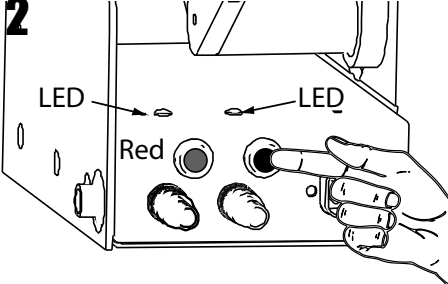
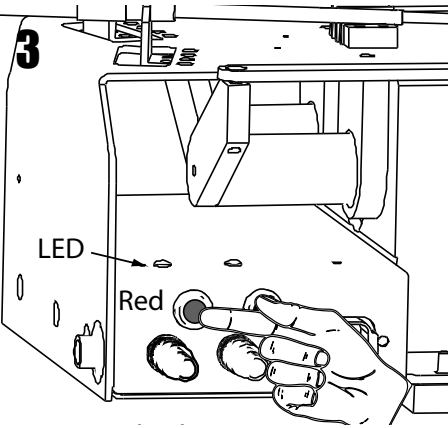
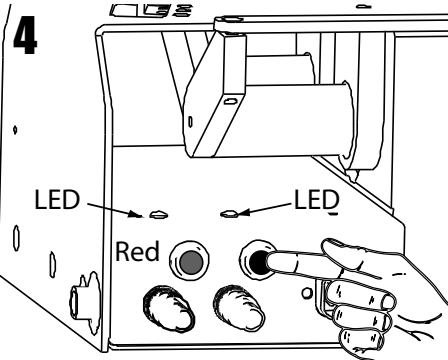
Setting the Actuator Identifier is necessary to enable the Smart Actuator to “talk” to the CANbus network.

IF YOU PURCHASED A COMPLETE SYSTEM, THE ACTUATOR IDENTIFIER WAS PERFORMED AT THE FACTORY. ALL THAT IS NEEDED BY THE INSTALLER IS TO CALIBRATE THE ACTUATOR ENDPOINTS AND CABLE DIRECTION. If you purchased an Actuator separately, you may need to set the Actuator identifier (see instructions below) for that Actuator as well as perform calibration for the endpoints and cable direction (see Section 4.0).

	<p>ACTION</p> <p>Press & Release the RED button on the Smart Actuator 4 times</p>	<p>RESULT</p> <p>The LED above the RED button will begin to flash 4 times, pause then repeat</p>																		
	<p>Press & Release the BLACK button to select Actuator Identifier Configuration</p>	<p>The RED LED will continue to flash to indicate which menu you are currently in The BLACK LED will indicate the available selections within this menu.</p>																		
	<p>ACTION</p> <p>Press & Release the RED button on the Smart Actuator until the desired Actuator Identifier is achieved (indicated by BLACK LED)</p>	<table border="1"> <thead> <tr> <th colspan="2" data-bbox="787 1096 1193 1150">RESULT</th> </tr> <tr> <th data-bbox="787 1150 876 1203">ID#</th> <th data-bbox="876 1150 1526 1203">ACTUATOR DESCRIPTION</th> </tr> </thead> <tbody> <tr> <td data-bbox="787 1203 876 1255">1</td> <td data-bbox="876 1203 1526 1255">PORT Throttle/Gear</td> </tr> <tr> <td data-bbox="787 1255 876 1308">2</td> <td data-bbox="876 1255 1526 1308">STBD Throttle/Gear</td> </tr> <tr> <td data-bbox="787 1308 876 1360">3</td> <td data-bbox="876 1308 1526 1360">PORT/STBD Troll</td> </tr> <tr> <td data-bbox="787 1360 876 1413">4</td> <td data-bbox="876 1360 1526 1413">PORT/STBD Throttle w/ solenoid shift</td> </tr> <tr> <td data-bbox="787 1413 876 1465">5</td> <td data-bbox="876 1413 1526 1465">PORT / STBD Gear</td> </tr> <tr> <td data-bbox="787 1465 876 1543">6</td> <td data-bbox="876 1465 1526 1543">CENTER Throttle / Gear</td> </tr> </tbody> </table>			RESULT		ID#	ACTUATOR DESCRIPTION	1	PORT Throttle/Gear	2	STBD Throttle/Gear	3	PORT/STBD Troll	4	PORT/STBD Throttle w/ solenoid shift	5	PORT / STBD Gear	6	CENTER Throttle / Gear
RESULT																				
ID#	ACTUATOR DESCRIPTION																			
1	PORT Throttle/Gear																			
2	STBD Throttle/Gear																			
3	PORT/STBD Troll																			
4	PORT/STBD Throttle w/ solenoid shift																			
5	PORT / STBD Gear																			
6	CENTER Throttle / Gear																			
	<p>Press & Release the BLACK button to store actuator identifier in memory</p>	<p>This action will return you to the main configuration menu indicated by BOTH LEDs flashing.</p> <p>Once identifier is stored in memory you may:</p> <ol style="list-style-type: none"> 1) continue to configure the setting of the Tachometer Pulses/Revolution (PPR) OR . . . 2) you may EXIT CONFIGURATION MODE by turning Power OFF. 																		

7.7.3 — Setting the Tachometer Pulses / Revolution (PPR):

Engine RPM tachometer sensors are used in mechanical throttle applications to give a better engine RPM matching control while using the sync feature. When in Sync mode, the Smart Actuator uses the rpm information feedback from the tachometer sending units to keep the slave engine rpm matched with the master engine rpm. In order for the sync function to work properly, the system has to know what type of tachometer sender it is attached to. A tachometer sending unit (external to the Smart Actuator) is a device that converts engine RPM to a voltage sine wave signal. The senders usually come in two types, 4 pulses per 1 engine RPM or 6 pulses per 1 engine RPM.

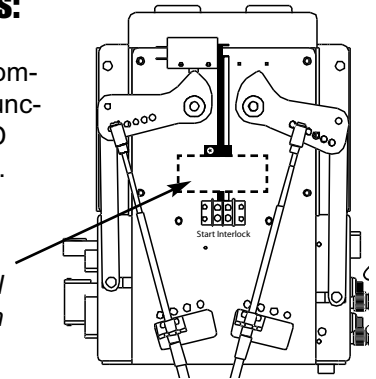
	<p>ACTION</p> <p><i>Press & Release the RED button on the Smart Actuator 5 times</i></p>	<p>RESULT</p> <p><i>The LED above the RED button will begin to flash 5 times, pause then repeat</i></p>											
	<p><i>Press & Release the BLACK button to select Tachometer Pulses / Revolution Configuration</i></p>	<p><i>The RED LED will continue to flash to indicate which menu you are currently in The BLACK LED will indicate the available selections within this menu.</i></p>											
	<p>ACTION</p> <p><i>Press & Release the RED button on the Smart Actuator until the desired Tachometer PPR is achieved (indicated by BLACK LED)</i></p>	<p>RESULT</p> <table border="1" data-bbox="795 1155 1528 1541"> <thead> <tr> <th>ID#</th> <th>LEDs ON</th> <th>SELECTION DESCRIPTION</th> </tr> </thead> <tbody> <tr> <td>1</td> <td>BLACK FLASHES 1 TIME</td> <td>4 PPR — generally used with Aetna Tachometer sender units using 1/2 engine speed drive adapters</td> </tr> <tr> <td>2</td> <td>BLACK FLASHES 2 TIMES</td> <td>6 PPR — generally used with outboards generating a 6 pulse per revolution tachmeter signal (Yamaha, Evinrude, etc.)</td> </tr> </tbody> </table>			ID#	LEDs ON	SELECTION DESCRIPTION	1	BLACK FLASHES 1 TIME	4 PPR — generally used with Aetna Tachometer sender units using 1/2 engine speed drive adapters	2	BLACK FLASHES 2 TIMES	6 PPR — generally used with outboards generating a 6 pulse per revolution tachmeter signal (Yamaha, Evinrude, etc.)
ID#	LEDs ON	SELECTION DESCRIPTION											
1	BLACK FLASHES 1 TIME	4 PPR — generally used with Aetna Tachometer sender units using 1/2 engine speed drive adapters											
2	BLACK FLASHES 2 TIMES	6 PPR — generally used with outboards generating a 6 pulse per revolution tachmeter signal (Yamaha, Evinrude, etc.)											
	<p><i>Press & Release the BLACK button to store Tachometer PPR in memory</i></p>	<p><i>This action will return you to the main configuration menu indicated by BOTH LEDs flashing.</i></p> <p><i>Once Tachometer PPR is stored in memory you may EXIT CONFIGURATION MODE by turning Power OFF.</i></p>											

7.7.4 To Set Cable Direction for Actuator's RIGHT side, follow these steps:

It may become necessary to change the cable travel direction after calibration has been completed. If so, verify that you are changing the cable direction for the appropriate Actuator function by locating the Serial Number label located on the front (or top) of the Actuator. The ID number signifies that the Actuator has been set up for a particular propulsion arrangement. Actuator's RIGHT SIDE function depends on the Actuator ID switch setting (see below):

- ACT ID#1 or #2 — Throttle lever on a throttle/gear Actuator
- ACT ID#3 — PORT Troll lever on a troll/troll Actuator
- ACT ID#4 — PORT Throttle lever on a throttle/throttle Actuator
- ACT ID#5 — PORT Gear lever on a gear/gear Actuator

To set the RIGHT SIDE of the **Actuator's** Cable Direction, follow the steps below:

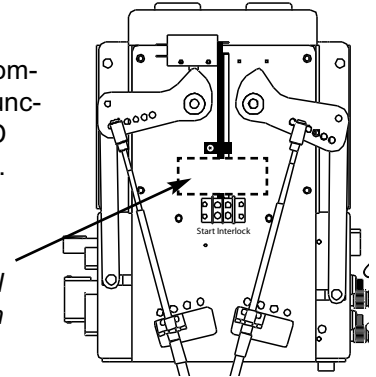


1		ACTION	RESULT	
		Turn power to Smart Actuators ON	N/A	
2		Press & Release in sequence the RED then the BLACK then the RED buttons on the Smart Actuator (you have 5 seconds to complete process)	Both LEDs above the RED and BLACK buttons will flash to indicate that you have entered Smart Actuator Configuration Mode	
3		Press & Release the RED button on the Smart Actuator 1 time to select RIGHT SIDE Cable Direction Menu	RED LED will flash one time, pause and then repeat	
4		Press & Release the BLACK button 1 time to select RIGHT SIDE cable direction configuration	The RED LED will continue to flash to show you what menu you are in. The BLACK LED will illuminate to indicate which selection you have chosen below.	
5		Press & Release the RED button until the desired Actuator cable direction is indicated by the LEDs (see chart at right)	LED 2 (BLACK)	TRAVEL DIRECTION
			FLASHED 1 TIME	PUSH direction
			FLASHES 2 TIMES	PULL direction
6		When the desired cable direction is displayed on the LEDs, Press & Release the BLACK button to store it in memory	This action will return you to the main configuration menu indicated by BOTH LEDs flashing quickly	
7		Turn OFF power to the Smart Actuators and RESTART	N/A	

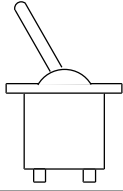
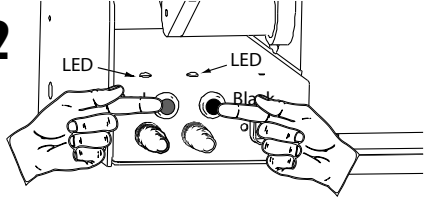
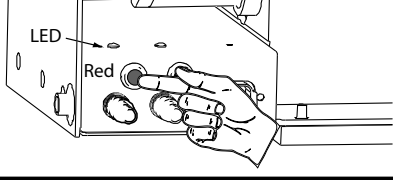
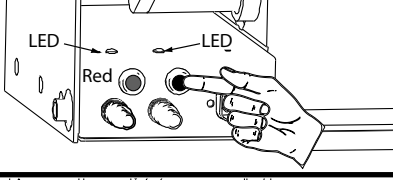
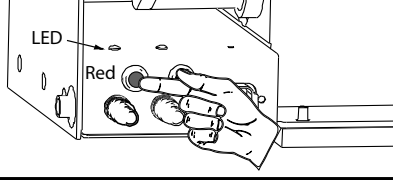
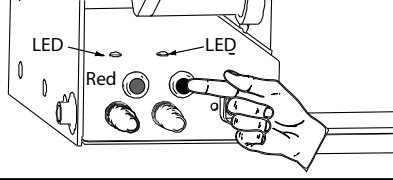
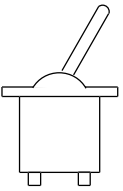
To Set Cable Direction for Actuator's LEFT side, follow these steps:

It may become necessary to change the cable travel direction after calibration has been completed. If so, verify that you are changing the cable direction for the appropriate Actuator function by locating the Serial Number label located on the front (or top) of the Actuator. The ID number signifies that the Actuator has been set up for a particular propulsion arrangement. Actuator's LEFT SIDE function depends on the Actuator ID switch setting (see below):

- ACT ID#1 or #2 — Gear lever on a throttle/gear Actuator
- ACT ID#3 — STBD Troll lever on a troll/troll Actuator
- ACT ID#4 — STBD Throttle lever on a throttle/throttle Actuator
- ACT ID#5 — STBD Gear lever on a gear/gear Actuator



To set the LEFT SIDE of the **Actuator's** Cable Direction, follow the steps below:

1 ON  OFF	ACTION	RESULT	
	Turn power to Smart Actuators ON	N/A	
2 	Press & Release in sequence the RED then the BLACK then the RED buttons on the Smart Actuator (you have 5 seconds to complete process)	Both LEDs above the RED and BLACK buttons will flash to indicate that you have entered Smart Actuator Configuration Mode	
3 	Press & Release the RED button on the Smart Actuator 2 times to select LEFT SIDE Cable Direction Menu	RED LED will flash two times, pause and then repeat	
4 	Press & Release the BLACK button 1 time to select LEFT SIDE cable direction configuration	The RED LED will continue to flash to show you what menu you are in. The BLACK LED will illuminate to indicate which selection you have chosen below.	
5 	Press & Release the RED button until the desired Actuator cable direction is indicated by the LEDs (see chart at right)	LED 2 BLACK	TRAVEL DIRECTION
		FLASHES 1 TIME	PUSH direction
		FLASHES 2 TIMES	PULL direction
6 	When the desired cable direction is displayed on the LEDs, Press & Release the BLACK button to store it in memory	This action will return you to the main configuration menu indicated by BOTH LEDs flashing quickly	
7 ON  OFF	Turn OFF power to the Smart Actuators and RESTART	N/A	

7.8 Triple Engine Applications (optional)

A. Description

The Smart Actuator System is able to control the throttles and transmissions for multiple engine applications. The control head handle is designed and programmed to control three engines from 2 handles. In order for the Smart Actuator System to control multiple engines, an additional Smart Actuator must also be installed (see layout drawing following this section).

B. Operation

When installed properly, the PORT engine control handle controls the port engine – functioning in the same way as a standard control. The STBD (starboard) engine control handle controls the starboard engine – functioning in the same way as a standard control.

For gear shift, the center engine is put into gear by moving BOTH the PORT and STBD engines into the same gear. If the PORT engine goes into gear, but the STBD engine is in neutral or in the opposite gear (during maneuvering), then the center engine stays in neutral.

If the STBD engine goes into gear, but the PORT engine is in neutral or in the opposite gear (during maneuvering), then the center engine stays in neutral. However, if both the port and starboard engine are placed into the same gear (either ahead or reverse), then the center engine will respond the same way.

For throttle control of the center engine, the engine speed will be the same as the lowest speed of either the PORT or STBD engine. Of course, during normal operation, the center engine will only throttle up if both the PORT and STBD engines are placed in the same gear.



While in WARM mode, the center engine will respond the same way as above. However, the gear on all the engines will not respond while in WARM mode – all engines will remain in neutral.

Triple Engine Activation Switches

The position of the switches on the control panel at the helm station will determine which of the engines will respond to the control head.

If all of the switches are in the ON position, then the engines will respond as described above. If any of the switches on the control panel are in the OFF position, then the engine associated with that switch will remain in the neutral / idle control position – the engine will not go into gear, it will not speed up.

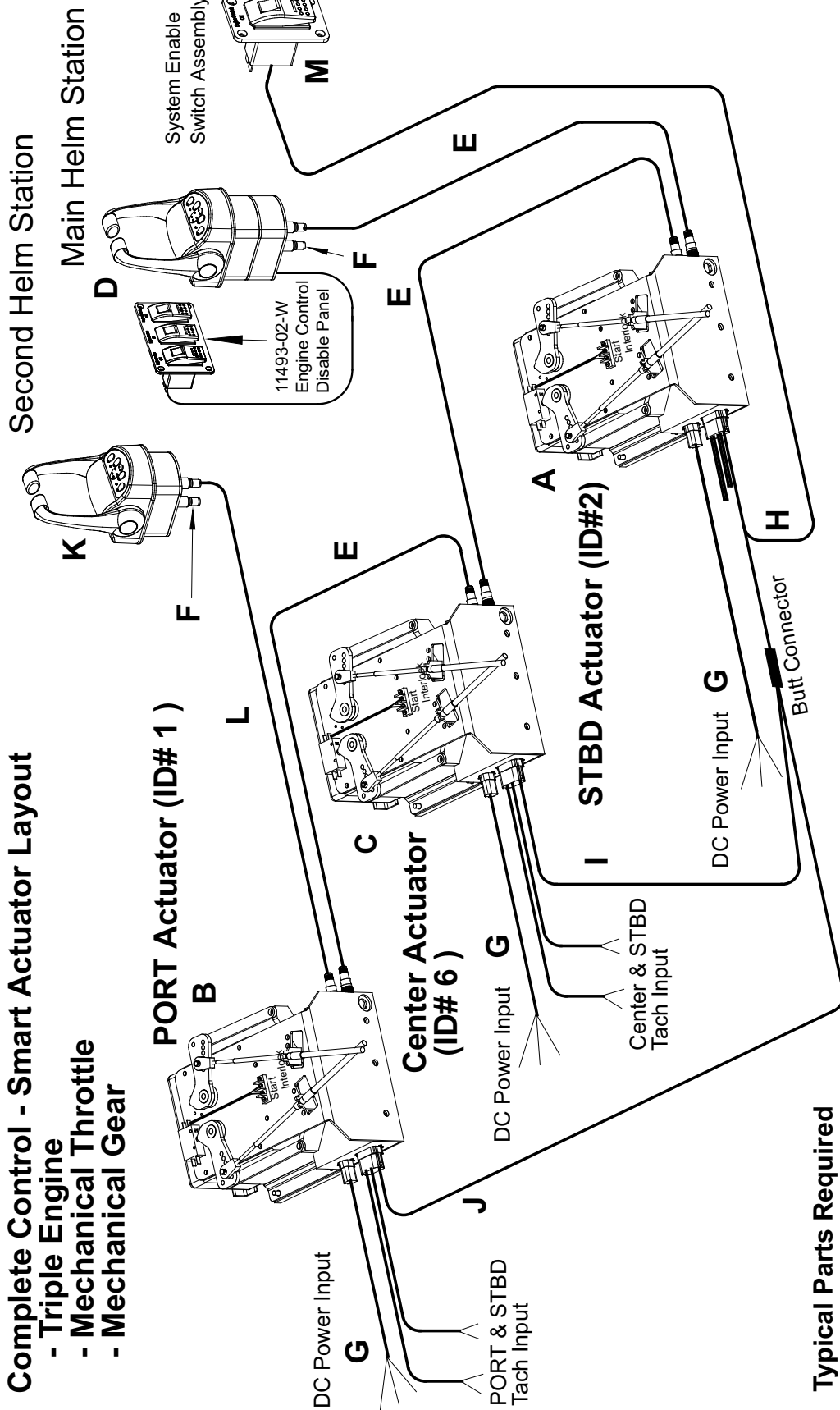
If the center engine is turned off, then it will remain in neutral, while the port and starboard engines respond normally. If either the port or starboard engine switch are turned off, then the center engine will be controlled by the PORT or STBD control handle (whichever button is turned off). If ONLY the center engine switch is on, then the center engine will be controlled by the starboard handle.



The control system will only respond to a change in the switch position when the control handles are in neutral. Manipulating the switches while the engines are in gear will have no effect, until after the control handles are returned to neutral.

Complete Control - Smart Actuator Layout

- Triple Engine
- Mechanical Throttle
- Mechanical Gear



Typical Parts Required

ITEM	QTY	PART#	DESCRIPTION
A	(1)	11312-XX-TMG-S	Smart Actuator STBD (12 or 24VDC)
B	(1)	11312-XX-TMG-P	Smart Actuator PORT (12 or 24VDC)
C	(1)	11312-XX-TMG-C	Smart Actuator CENTER (12 or 24VDC)
D	(1)	11413-CT-CP	CH2001 Control Head 4 button CP
E	(3)	11600-02-XX	Station Cables (20 - 100' long)
F	(2)	11600-TRF	Terminating Resistors
G	(3)	11601-01	Harness - DC Power Input (30' long std.)
H	(1)	11603-02-S-XX	Harness - Enable STBD (20 - 100' long)
I	(1)	11603-02-P	Harness - Enable/Tach PORT (30' long)
J	(1)	11603-02-C	Harness - Enable/Triple Center Engine (30' long)
EXTRA CONTROL STATION REQUIRES			
K	(1)	11413-C15T	CH2001 Control Head 4 button
L	(1)	11600-02-XX	Station Cable (20 - 100' long)
OPTIONAL ENABLE SWITCH ASSEMBLY			
M	(1)	11490-X	Enable Switch Assembly (Black or White Nameplate)

Complete Control - Smart Actuator Harnesses

