

Smart Actuator II™
Installation & Operation Manual v3.7a

Complete Controls *by Glendinning*



*WARNING: DISCONNECT SYSTEM'S GROUND AND BONDING
BEFORE ANY WELDING ACTIVITY ON BOARD VESSEL!*



Glendinning Marine Products, Inc.
740 Century Circle
Conway, SC 29526
(843) 399-6146
Fax: (843) 399-5005
www.glendinningprods.com

MANUAL REVISIONS

REVISION	PAGE #	DESCRIPTION	DATE of CHANGE
3.7a	N/A 73-90	Updated Software to version 3.7 Section 7.5 - added Fixed Gear and Dynamic Gear Delay options. Also updated Throttle and Neutral Delay options.	MAY 2008
3.6d	39 40 86-90	Sec. 6.0 - changed low battery alarm to 10v/19v Sec. 6.0 - added Actuator #5 alarm codes Sec. 7.5 - added new configuration options 7.5.13 thru 7.5.16	NOVEMBER 2007
3.6c	91	Sec. 7.8 - added Triple Engine Applications	JUNE 2007
3.6b	85-87	Sec. 7.7 - added Acutator configurations to section	MAY 2007
3.6a	41	Sec. 7.2 - changed layout drawings	APRIL 2007
3.6	--	Initial startup of document	APRIL 2007

Chapters at a Glance

1.0	System Description & Capabilities	1
1.1	System Components	1
1.2	System Layout	3
2.0	Operating the Smart Actuator II™	5
2.1	System Startup	5
2.2	Cruise Mode	6
2.3	Warm Up Mode	7
2.4	Slow Mode	8
2.5	Automatic Synchronization Mode	9
2.6	Troll Mode	9
2.7	Station Transfer Process	10
2.8	Warning Mode	11
2.9	Alarm Mode	12
3.0	Installing the Smart Actuator II™	13
3.1	Pre-Installation Planning	15
3.2	Engine Compartment - Mount the Smart Actuator II™	16
3.3	Engine Compartment - Control Cable Connections	16
3.4	Engine Compartment - Electrical Connections	18
3.5	Mounting the Control Head	23
3.6	Integrated Trim Control (optional)	25
4.0	Smart Actuator II™ Endpoint Calibration	27
4.1	Calibrating Actuator Endpoints & Cable Direction	28
4.2	Endpoint Calibration Verification	30
5.0	System Test & Checkout	31
5.1	Component Installation Checks	31
5.2	Operational Checks	31
6.0	Troubleshooting Mode	33
6.1	To Retrieve Alarm Count and/or Alarm Codes	33
6.2	To Delete Alarm Codes and Exit Handle Troubleshoot Mode	34
6.3	To Exit Handle Troubleshoot Mode	34
7.0	Appendix / References	41
7.1	Wiring Diagrams	43
	SINGLE Engine Wiring Diagram	43
	TWIN Engine Wiring Diagram	44
	TWIN Engine w/TROLL Wiring Diagram	45
	TWIN Engine w/ELECTRIC GEAR Wiring Diagram	46
	Smart Actuator II™ Harnesses	47
7.2	Dimensional Drawings / Cutout Templates	51
	Actuator Dimensions	51
	Actuator Mounting Dimensions	52
	Actuator Parts	53
	2-button Control Head (Remote) Dimensions	54
	2-button Control Head CP Dimensions	55
	4-button Control Head (Remote) Dimensions	56
	4-button Control Head CP Dimensions	57
	Cutout Templates for Control Heads	59
7.3	Sidemount Control Head (optional)	63



7.4 Control Head Configuration (setting handle IDs)71

7.5 Control Processor Functional Configuration74

7.5.1 Actuator Options74

7.5.2 Throttle on Top of Troll Options75

7.5.3 Troll Delay Options76

7.5.4 Throttle Delay Options77

7.5.5 Fixed Gear Delay Options78

7.5.6 High-Idle Step Size (pt. 1)79

7.5.7 High-Idle Step Size (pt. 2)80

7.5.8 System Startup Options81

7.5.9 Station Transfer Options82

7.5.10 Return System to Defaults Option83

7.5.11 Sync Gain Options84

7.5.13 Natural Delay Options85

7.5.15 Throttle Bump Amount Options86

7.5.16 Selectable Sync Master Options87

7.5.17 Throttle Curve Select Options88

7.5.18 Dynamic Gear Delay Options90

7.6 Actuator Functional Configuration91

7.6.1 Setting Actuator Defaults Option91

7.6.2 Setting Actuator Identifier92

7.6.3 Setting Tachometer Pulses / Revolution (PPR)93

7.6.4 Setting Cable Travel Direction ONLY94

7.7 Triple Engine Applications (optional)97

 Description97

 Operation97

 TRIPLE Engine Wiring Diagrams98

 TRIPLE Engine Harnesses99

A word about the Symbols used in the Manual

When driving from one destination to another, road signs prove to be invaluable. Road signs are an important source of information. For example, road signs can warn you about potential problems ahead to help divert certain disaster or they can let you know where to turn off for a rest or a meal.

In an effort to help you navigate your way through this manual we will from time to time use the following symbols:



Throughout the manual the NOTES symbol will appear to support what has been mentioned in the text. A note can be used where further explanation is needed or where something needs highlighting. BE CAREFUL to read all NOTES.



Sometimes it is helpful to take a break and really absorb what you just read. The WARNING symbol will alert the reader to information that needs to be completely understood before you continue on in the reading of the manual. ALWAYS STOP and READ these points.



The TIP symbol will be used when something mentioned in the text need more “light” shed on it. The tip could explain or be a list of do’s and don’ts. Whatever the TIP is, you do not want to miss out on the information it contains.

1.0 System Description & Capabilities

With the advent of electronically controlled engines in the marine industry, *GLENDINNING* has developed the Complete Controls System to be compatible with all types of electronically & mechanically governed engines and will provide the boat operator with total control over the boat's propulsion system. The Complete Control System incorporates the following standard features:

- *Single lever control from up to 6 control stations* — Single lever control permits gear and throttle control using a single control lever. The Complete Controls control processor correctly sequences the operation of engine and transmission, so that the engine and transmission are protected during shifting at up to 6 separate helm control stations. Only one station is in control of the propulsion plant at any time.
- *Adjustable control head detent / friction settings* — This feature allows for the setting of the control head detent and/or friction quickly and easily while underway, without disassembling the control head!
- *“Posi-lock” gear lockout* — A dedicated button (WARM) is provided to lockout the gear and allows engine RPM to be increased safely.
- *Battery voltage warning indicator* — Our system alerts you when either too low or too high voltage exists. The control system will continue to operate as long as possible, within the limits of its operating voltage.
- *System diagnostic warning indicator* — The Complete Controls System monitors many parameters and notifies you when conditions fall outside suitable operating range.
- *Neutral gear position indicating lights* — You know that the transmission has shifted into neutral gear with this visual gear position indicator.
- *Two button station transfer* — No more accidental transfer of control from one station to another. Our system's TAKE button must be depressed twice in order to transfer control from one station to another.
- *Control Head Lights Dimmer* — This feature allows the LED brightness on the control head keypad to be dimmed for night operation.

In addition to these standard features, the Complete Controls system includes the following optional features that are available with the upgraded 4-button control head:

- *Adjustable control head detent / friction settings* — This feature allows for the setting of the control head detent and/or friction quickly and easily while underway, without disassembling the control head!
- *High idle mode* — Up to 10 idle speeds are available and can be adjusted through system calibration.
- *Bump mode* — Want to make minute adjustments in engine speed (approx. 10-15 RPM)? Simply press the WARM or TROLL buttons!
- *Slow mode* — Limits maximum RPM available to approximately 50% of normal WOT. Very useful for maneuvering or slow speed cruising (SLOW).
- *Gear position indicating lights* — You know that the transmission has shifted into the appropriate gear with this visual gear position indicator.
- *Control head light dimmer* — Bright lights are great for daylight conditions, but can be distracting at night. This feature allows you to dim the control head lights for each station individually.

1.1 System Components

The Complete Control System consists of 4 separate components. They are:

Control Head

The Control Head is by far the most informative control head in the industry today. The control head keypad has integrated switches and indicator lights which allow the boat operator to control all aspects of the boat's propulsion system.



4-Button Control Head 2-Button Control Head Single Engine Control Head Integrated Trim Control Head



OPTIONAL Handheld Remote Control allows boat operator to control both throttle and transmission from almost anywhere on board his vessel.



4-BUTTON KEYPAD



2-BUTTON KEYPAD



INTEGRATED TRIM CONTROL KEYPAD

Robust, watertight construction is a hallmark at *Glendinning* — we build our control heads to withstand the extreme conditions that exist in the marine environment.

Smart Actuator II™

The electromechanical actuators convert the electronic commands that are generated by the control head into specific positions at the engine gear, throttle and trolling valve. The actuators are housed in rugged, corrosion resistant, aluminum enclosures that are sealed to eliminate problems which may be caused by exposure to the marine environment. The actuator motor drive assembly uses precision ground steel gears and components that are manufactured to very precise tolerances. Combined with a high frequency pulse width modulation (PWM) input, the actuator is able to resolve a linear position of less than 0.010 inch very smoothly with no “steps.”

Smart Actuator II™



Station Communication Cables

Glendinning’s station communication cables are pre-terminated at the factory for ease of installation, and are completely shielded to eliminate problems caused by electromagnetic interference, complying with the latest and strictest standards in the industry. Both ends of the station communication cable has a connector which is identical on either end—no mistakes when it comes to plugging in the cable!

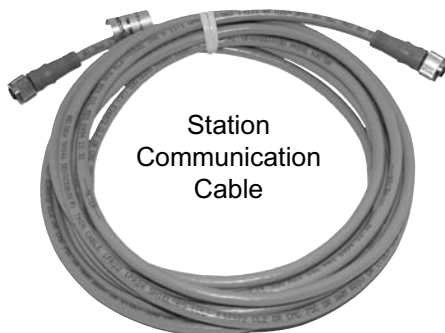

Station Communication Cable



CLOSE-UP Station Communication Cable Connector

1.2 System Layout

SINGLE ENGINE

- Mechanically controlled engine & transmission
- Single station application shown - 1-6 station are possible

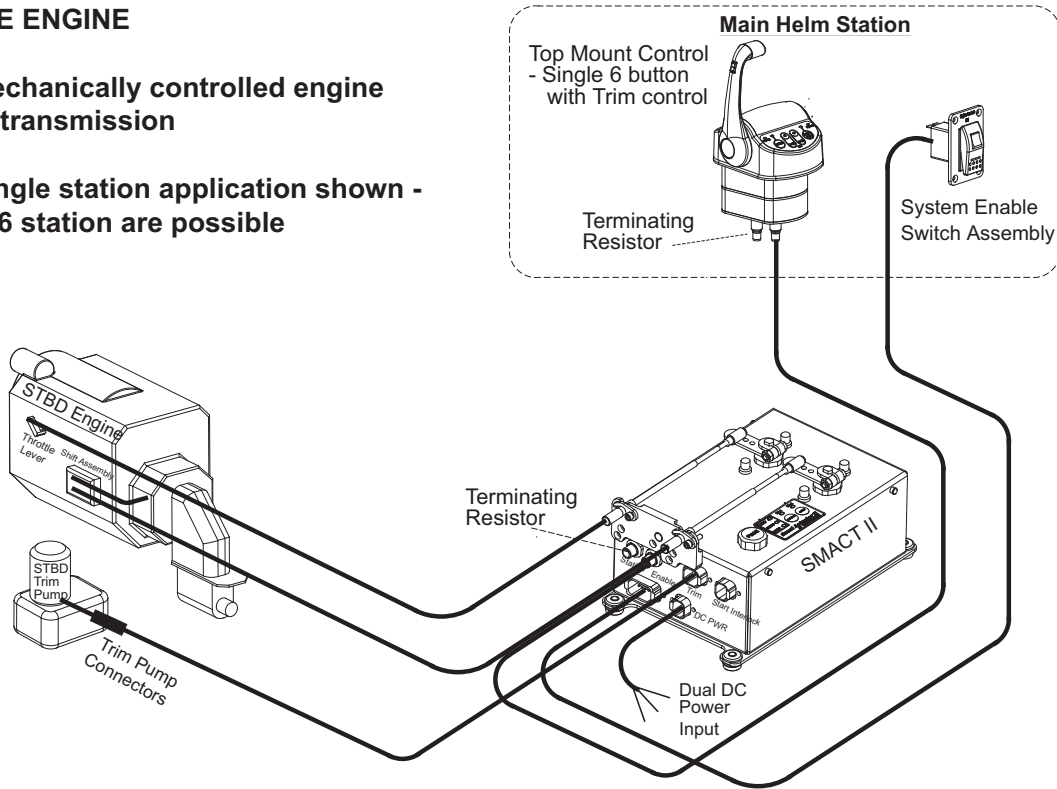

TWIN ENGINE

- Mechanically controlled engine & transmission
- Twin station application shown 1-6 stations possible

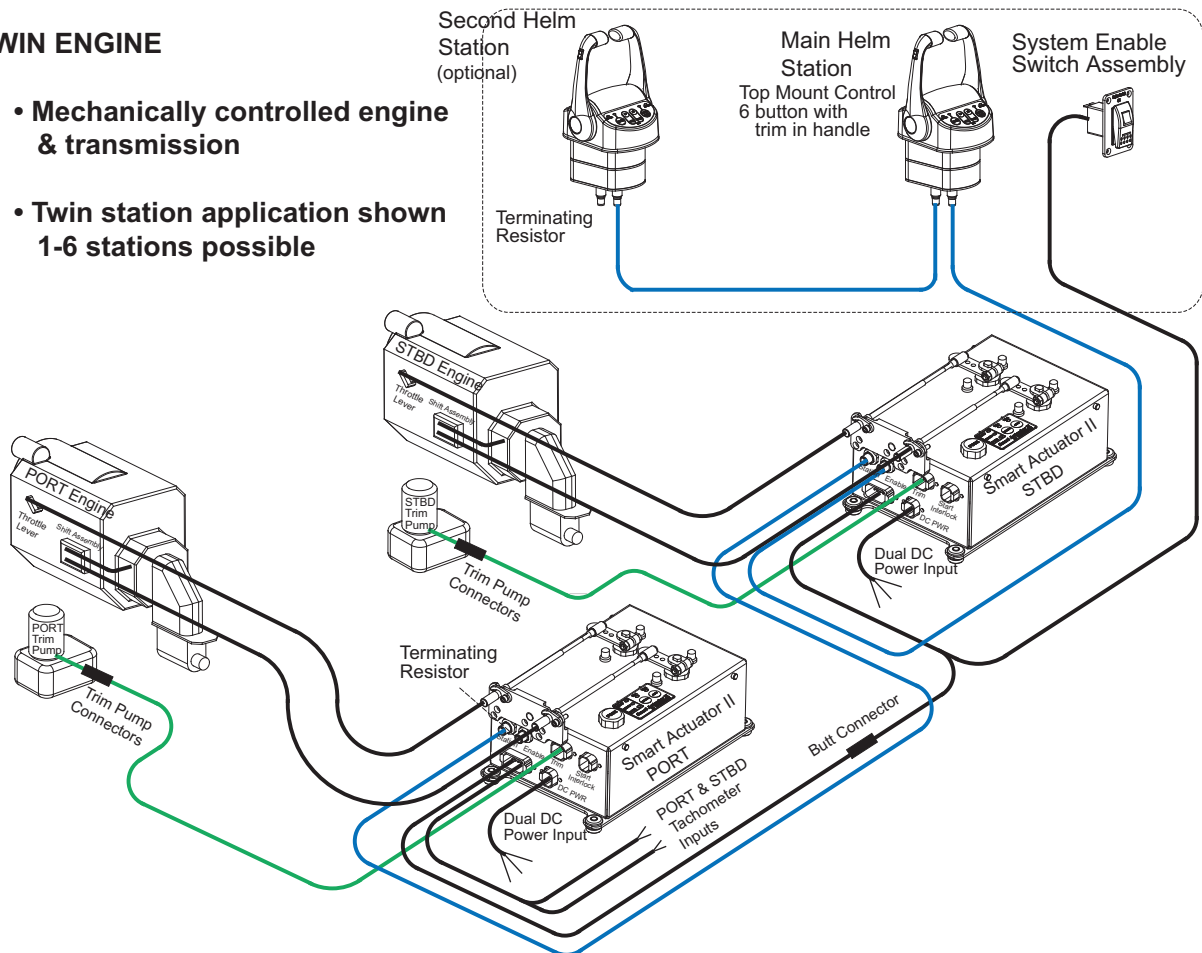

TWIN ENGINE with ELECTRIC GEAR

- Mechanically controlled engine
- Electrically controlled transmission

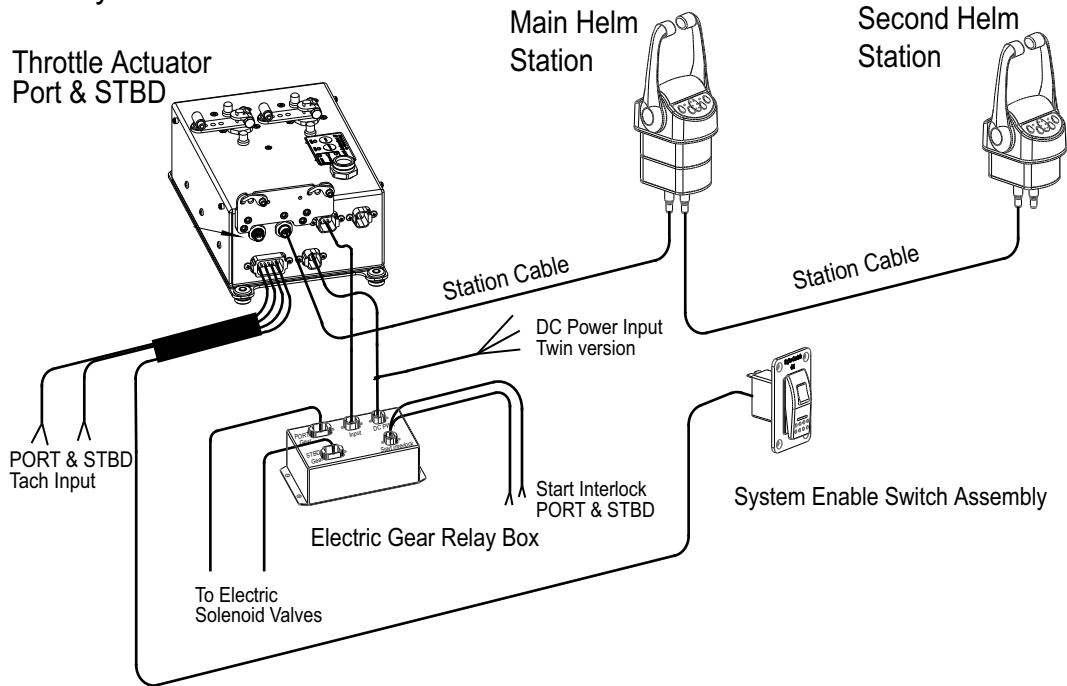

TWIN ENGINE with TROLLING VALVES

- Mechanically controlled engine & transmission
- Twin station
- Trolling valves

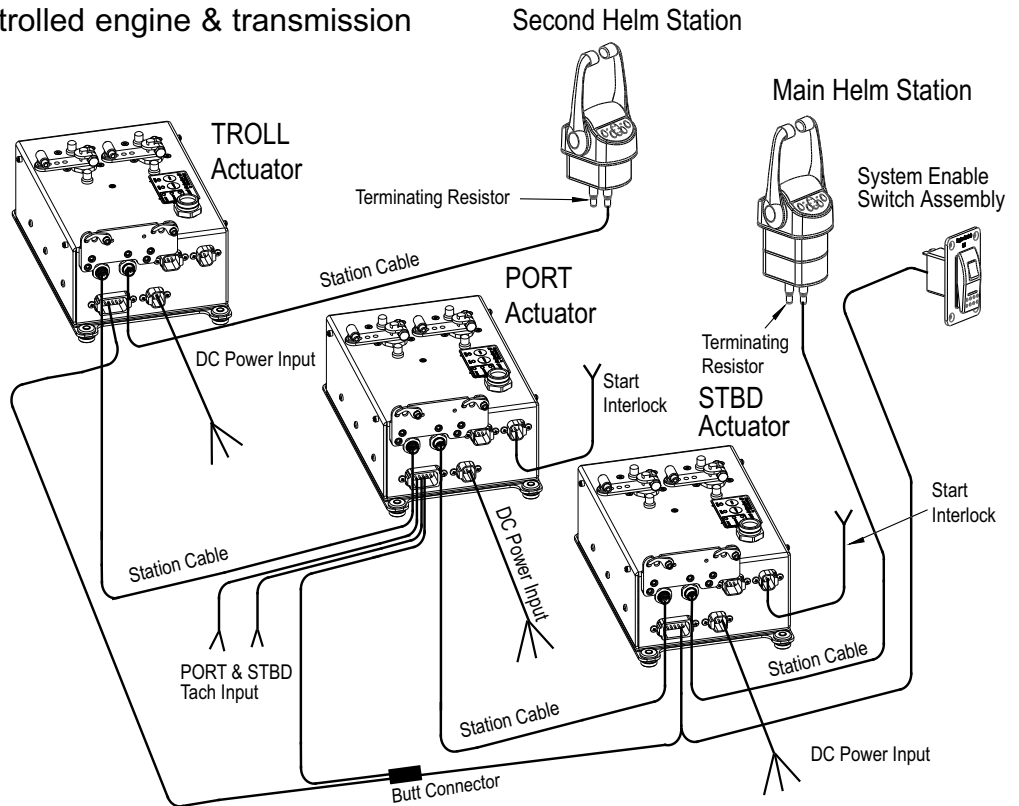

2.0 Operating the Smart Actuator II™

Operating the Smart Actuator II™ is just as easy as the installation process. The Control Head will constantly monitor various parameters and will alert the boat operator if the system falls outside the normal operating range. Familiarize yourself with the following functions BEFORE operation.

The functions necessary for operating are:

- 2.1 — System Startup Procedure
- 2.2 — Cruise Mode
- 2.3 — Warm Up Mode
- 2.4 — Automatic Synchronization Mode
- 2.5 — Station Transfer Process
- 2.6 — Warning Mode
- 2.7 — Alarm Mode

It should be noted that the Smart Actuator II™ system can be operated by 3 types of control heads depending on your propulsion system requirements, they are:

- 1) **4-button control head** — this is the control head that is used when all the features of the system are required;
- 2) **2-button control head** — this control head is for basic operation of the system; and
- 3) **Integrated Trim (ITC) control head** — is used when the optional control of trim / tilt of engine drive unit is preferred.

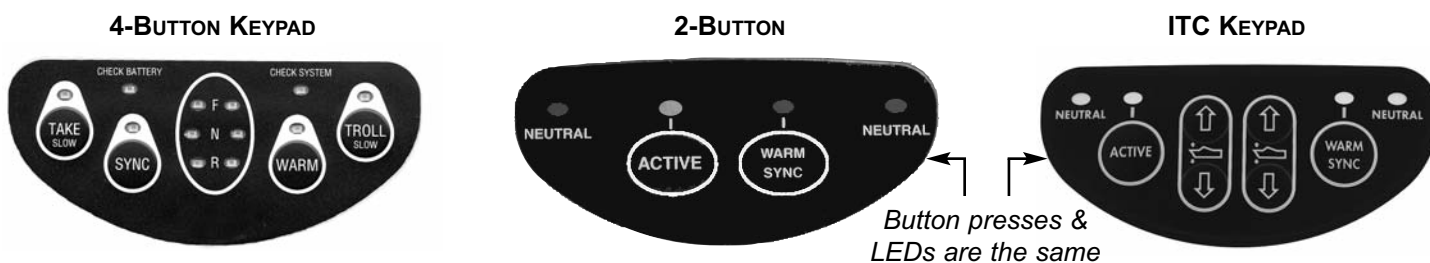

For illustrative purposes in this manual the keypad button presses and LED illuminations for the 2-button control head and the ITC control head are the same.





2.1 System Startup

KEYPAD LED ILLUMINATION		
= Fully Illuminated	= Slow Flash	= Blinking in Unison

Step	Diagram	ACTION	RESULT
Step 1		Control handles must be in the Neutral position prior to the startup of the system	N/A
Step 2		Turn system ON by using the system enable switch or keyswitches.	The system will perform a brief diagnostic test indicated by the following keypad lights being briefly illuminated. 4-button — TAKE 2-button — ACTIVE
Step 3		System is fully operational when the appropriate keypad lights are fully illuminated (see right).	4-button keypads: TAKE, PORT & STBD Neutral, and WARM lights 2-button keypads: ACTIVE, WARM/SYNC, and PORT / STBD Neutral lights









If the system does not startup as outlined in Sec. 2.1 — System Startup, check the following:

<p>4-BUTTON KEYPAD</p>  <p>2-BUTTON KEYPAD or ITC KEYPAD</p> 	<p>ACTION</p> <p>The control head beeps and the TAKE or ACTIVE light flashes slowly.</p>	<p>RESULT</p> <p>The control head handles are not in their NEUTRAL position. Leave control system enable switch ON and move one control handle at a time to verify that handles are in the Neutral position</p>
<p>4-BUTTON KEYPAD</p>  <p>2-BUTTON KEYPAD or ITC KEYPAD</p> 	<p>All four (4) keypad lights flash in unison.</p>	<p>System is in ALARM Mode. Restart the system by turning OFF the system enable switch and then turning switch back ON.</p>

If the system goes back into Alarm Mode after restarting, the alarm code recovery procedure must be followed to determine the reason for the alarm — see Section 6.0 - Troubleshooting Mode.

2.2 Cruise Mode





Cruise Mode is the normal operating mode. The Control Head may respond in one of three ways during Cruise Mode:

<p>Active Station</p> <p>4-BUTTON KEYPAD</p>  <p>2-BUTTON KEYPAD or ITC KEYPAD</p> 	<p>DESCRIPTION</p> <p>During normal operation only the active station will be in command. ACTIVE or TAKE light will be fully illuminated (not flashing) indicating that the station is “active” and in command of boat’s propulsion system.</p>
<p>Inactive Station</p> <p>4-BUTTON KEYPAD</p>  <p>2-BUTTON KEYPAD or ITC KEYPAD</p> 	<p>During normal operation all other stations are “inactive”. The ACTIVE light or TAKE light and Gear positioning lights on each inactive station will blink every 2 seconds indicating that the control head is an inactive station. 4-button keypads ONLY — The Check Battery/Check System lights will operate.</p>
<p>Alarm Mode</p> <p>4-BUTTON KEYPAD</p>  <p>2-BUTTON KEYPAD or ITC KEYPAD</p> 	<p>During normal operation, the system continuously monitors parameters and will alert operator of alarm conditions when they exist. Alarm Mode is indicated by all four (4) keypad lights blinking in unison.</p>

Other Functions available from Cruise Mode are:



1. **THROTTLE “BUMP” MODE** — During normal operation, small changes in engine speed (approximately 10-15 RPM) may be made by pressing and releasing the buttons described below for your keypad style.

NOTE: Engine speed can only be “bumped” when control handles are in gear or above idle speed.

Step 1		ACTION	RESULT
<p>4-BUTTON KEYPAD</p> 	<p>2-BUTTON KEYPAD or ITC KEYPAD</p> 	<p>4-button keypad: Press & Release the TAKE button</p> <p>2-button keypad: Press & Release the ACTIVE button</p>	To INCREASE engine speed by using the Throttle “Bump” Mode.
<p>Step 2</p> <p>4-BUTTON KEYPAD</p> 	<p>2-BUTTON KEYPAD or ITC KEYPAD</p> 	<p>4-button keypad: Press & Release the TROLL button</p> <p>2-button keypad: Press & Release the ACTIVE & WARM button</p>	To DECREASE engine speed by using the Throttle “Bump” Mode.

2. **HIGH IDLE MODE** — (**HIGH IDLE MODE is only available with our 4-Button Keypad**) During normal operation, the boat operator is able to change the engine idle speed up to 10 different idle speed settings.

NOTE: Engine idle speed can only be changed when control handles are in NEUTRAL. Idle speed change can be adjusted during system calibration.

Step 1	ACTION	RESULT
<p>4-BUTTON KEYPAD</p> 	Press & Release the TAKE & SYNC button	To INCREASE engine idle speed by using the High Idle Mode.
<p>Step 2</p> <p>4-BUTTON KEYPAD</p> 	Press & Release the TAKE button	To RESET engine idle speed to lowest setting.

2.3 Warm Up Mode

Warm up Mode allows the boat operator to operate the engine throttle by itself, while locking the transmission in NEUTRAL. It is **STRONGLY RECOMMENDED** that the system be in Warm Up Mode **AT ALL TIMES** while boat is at the dock! This safety procedure will prevent the accidental engagement of transmission if the control head handles are inadvertently moved.

To utilize the Warm Up feature:

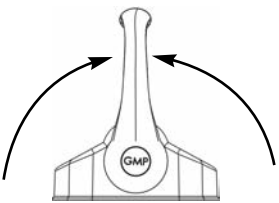
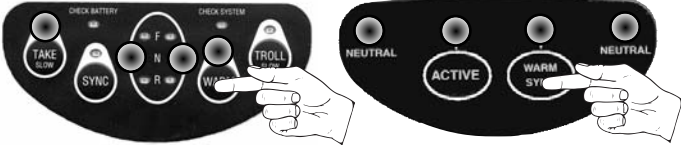
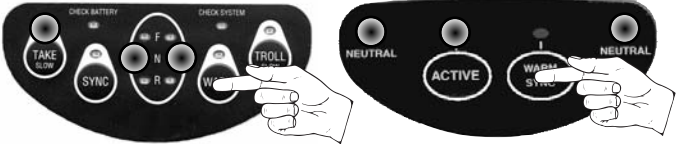
Step 1	ACTION	RESULT
	<p>Control handles must be in the Neutral position prior to entering WARM Mode</p>	<p>Gear position indicators should be fully illuminated.</p>
<p>Step 2</p> <p>4-BUTTON KEYPAD 2-BUTTON KEYPAD OR ITC KEYPAD</p> 	<p>To engage: Press & Release the WARM button one time</p>	<p>The WARM light should fully illuminate and the engine speed may now be increased while the gear is “locked” in the Neutral position.</p>
<p>Step 3</p> <p>4-BUTTON KEYPAD 2-BUTTON KEYPAD OR ITC KEYPAD</p> 	<p>To disengage: Bring handles to NEUTRAL position and Press & Release the WARM button one time</p>	<p>The WARM light will go OFF — engine gear position will now be able to be changed from Neutral to either Forward or Reverse.</p>

2.4 Slow Mode (only available on 4-button keypad)

The Slow Mode limits the maximum RPM available to approximately 50% of normal WOT. This feature is very useful for maneuvering or slow speed cruising.

The Slow Mode is activated by:

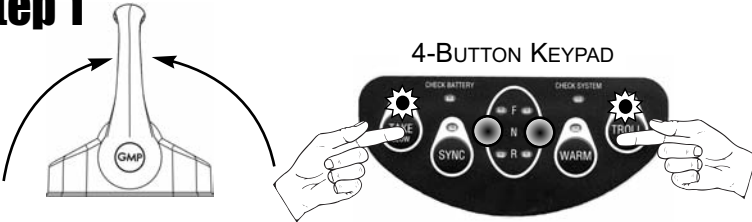
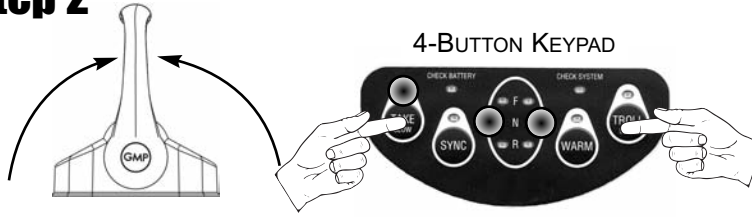



Step 1	ACTION	RESULT
<p>Step 1</p> 	<p>To engage: Bring handles to NEUTRAL position and Press & Release the TAKE & TROLL button</p>	<p>When engaged the TAKE & TROLL light will flash and moving control handles to Full Throttle position will yield only 50% of total throttle output.</p>
<p>Step 2</p> 	<p>To disengage: Bring handles to NEUTRAL position and Press & Release the TAKE & TROLL button</p>	<p>When disengaged the TROLL light will go OFF and the system will revert to normal operation.</p>

2.5 Automatic Synchronization Mode

The Automatic Synchronization Mode allows the control system to automatically control one engine speed to exactly match speed of the other engine. Think of it as cruise control for your boat. Once underway, follow the instructions below to activate this feature and control both engines' speed with one handle.

To activate the Automatic Synchronization Mode:

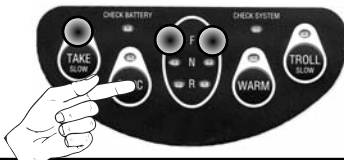
NOTE: Before the SYNC function can engage, both engines must be in the Ahead gear and handles must be in an approximately matched position — within 10% of total travel.



Step 1		ACTION	RESULT
<div style="display: flex; justify-content: space-around;"> <div style="text-align: center;"> <p>4-BUTTON KEYPAD</p>  </div> <div style="text-align: center;"> <p>2-BUTTON KEYPAD or ITC KEYPAD</p>  </div> </div>	<p>To engage: Press & Release the SYNC button one time.</p>	<p>SYNC light will go ON and system will automatically control the SLAVE engine speed to match the speed of the LEAD engine.</p>	
<div style="display: flex; justify-content: space-around;"> <div style="text-align: center;"> <p>4-BUTTON KEYPAD</p>  </div> <div style="text-align: center;"> <p>2-BUTTON KEYPAD or ITC KEYPAD</p>  </div> </div>	<p>To disengage: Move slave engine control handle to approximate position of lead and Press & Release the SYNC button one time.</p>	<p>SYNC light will go OFF and Automatic Synchronization Mode will be de-energized and the system will revert to normal operation.</p>	

NOTE: The Automatic Synchronization Mode will be automatically disengaged if **BOTH** control handles are moved to the NEUTRAL position together. If the LEAD (STBD) handle is moved to NEUTRAL gear position by itself, synchronization mode will be automatically de-energized. PORT engine operation will continue to match STBD engine operation (gear & throttle) until the PORT control handle is matched to STBD control handle position.

2.6 Troll Mode (only available on 4-button keypad)

The Troll Mode is available only if the boat has been equipped with trolling valves and allows the boat operator to control the position of the transmission trolling valves.

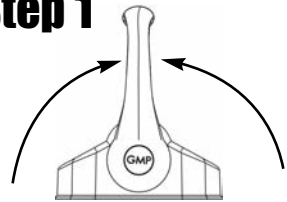
To activate Troll Mode:

Step 1		ACTION	RESULT
<div style="display: flex; align-items: center;">  <div style="margin-left: 20px;"> <p>4-BUTTON KEYPAD</p>  </div> </div>	<p>To engage: Bring handles to NEUTRAL position and Press & Release the TROLL button</p>	<p>When engaged the TAKE & TROLL light will be fully ON and moving control handles will control troll valve position.</p>	

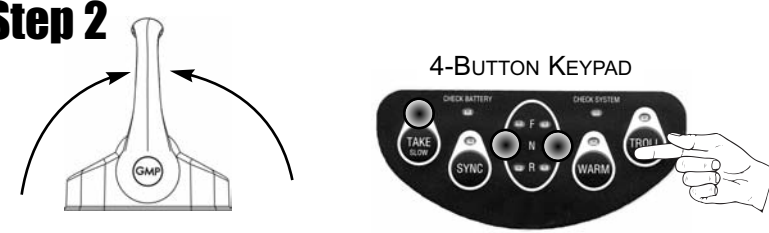

INSTRUCTIONS CONTINUED ON NEXT PAGE . . .

Step 2 	ACTION	RESULT
	To disengage: Bring handles to NEUTRAL position and Press & Release the TROLL button	When disengaged the TROLL light will be OFF and the system will revert to normal operation.





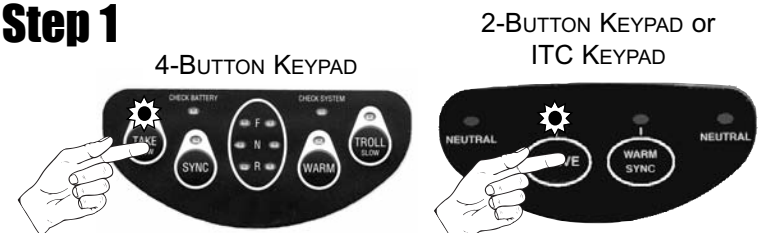
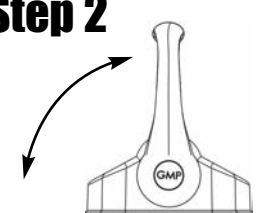

2.7 Station Transfer Process

The Complete Control System allows the propulsion system control to be transferred from one control station to another control station. This process requires the operator to depress the ACTIVE (2-button keypads) or TAKE button (4-button keypads) twice in order for the transfer to take effect thus avoiding any inadvertent transfers from taking place without the boat operator's knowledge.

To transfer control follow these steps from the helm station where you want to take control:

Step 1 	ACTION	RESULT		
	4-button keypad: Press & Release the TAKE button 2-button keypad: Press & Release the ACTIVE button	The TAKE or ACTIVE light will begin to blink and the control head will begin to beep.		
Step 2 	Active Station Handle Position	Station Taking Control Handle Position	Adjust the control head handles at the helm station where you want control to an appropriate throttle position	See the chart to the left for the appropriate control handle position.
	In Neutral	In Neutral		
	In gear, at Idle	In Neutral, or same gear position at Idle		
	In gear, above Idle	In Neutral, or same gear position at same or lower speed setting		
Step 3 	ACTION	RESULT	In order to complete the process the TAKE or ACTIVE buttons must be pressed a second time. The new helm station is now the active station indicated by the TAKE or ACTIVE light being fully ON & the control head stops beeping.	
	4-button keypad: Press & Release the TAKE button 2-button keypad: Press & Release the ACTIVE button	The TAKE or ACTIVE light will be fully ON and the control head will stop beeping.		



The illustrations on the next page further explain the light sequence at the INACTIVE station's keypad.

		DESCRIPTION
<p>Inactive Station</p> <p>4-BUTTON KEYPAD</p>  <p>2-BUTTON KEYPAD OR ITC KEYPAD</p> 		<p>Prior to pressing button, lights flash 1 time every 2 seconds — this is called the inactive station's heartbeat.</p>
<p>Inactive Station</p> <p>4-BUTTON KEYPAD</p>  <p>2-BUTTON KEYPAD OR ITC KEYPAD</p> 		<p>After pressing the button 1 time, TAKE or ACTIVE light will flash depending on handle setting at control station where keypad button is pressed. A beeping sound will also be audible from the control head.</p> <p>Slow flash — handles not in appropriate position. Quick flash — handles in appropriate position.</p>
<p>Active Station</p> <p>4-BUTTON KEYPAD</p>  <p>2-BUTTON KEYPAD OR ITC KEYPAD</p> 		<p>Once handles are in the appropriate position and while the lights are flashing, control transfer is completed by pressing the TAKE or ACTIVE button for a second time. This is indicated by the TAKE or ACTIVE light being fully ON and the beeping sound emitted by the control head going silent.</p>

2.8 Warning Mode



During operation of the Smart Actuator II™ System, the system will warn the operator when a problem is detected. System will continue to operate in unaffected functions.

4-Button Keypads:

<p><i>CHECK BATTERY light blinks</i></p>  <p>CHECK BATTERY INDICATOR will blink when battery voltage conditions exist that are questionable.</p>	<p>SYMPTOM</p> <p>1) Diagnostics tests have detected that battery voltage has fallen below the necessary operating range.</p>	<p>ACTION</p> <p>1) Determine cause of input power problem.</p> <p>2) System will continue to operate normally, unless battery exceeds system parameters. If this occurs system will be switched into Alarm Mode (see page 10).</p>
<p><i>CHECK SYSTEM light blinks</i></p>  <p>CHECK SYSTEM INDICATOR will blink when a possible problem has been detected within the system.</p>	<p>SYMPTOM</p> <p>1) Diagnostics tests have detected that part of the control system is not functioning normally.</p>	<p>ACTION</p> <p>1) Restart control system (turn OFF/ON). Move handles to Neutral during system startup.</p> <p>2) Determine part of system not operating properly (ie. gear, throttle, troll, etc.).</p> <p>3) Utilize alarm code recovery procedure to discover source of problem (see Operations Guide).</p>



2-Button Keypads:

The 2-Button keypad provides the same warnings as outlined for the 4-Button keypad. Because the 2-Button keypad does not have the “Check Battery” and “Check System” indicators, the way those warnings are displayed will be different.

		ACTION	RESULT
CHECK BATTERY WARNING	<p>2-BUTTON KEYPAD OR ITC KEYPAD</p> 	<p>Whatever function light is ON at the time of warning, that light will begin to flash 2 times, pause then repeat</p>	<p>Unaffected system functions will continue to operate normally.</p>
CHECK SYSTEM WARNING	<p>2-BUTTON KEYPAD OR ITC KEYPAD</p> 	<p>Whatever function light is ON at the time of warning, that light will begin to flash 3 times, pause then repeat</p>	<p>Unaffected system functions will continue to operate normally.</p>

2.9 Alarm Mode

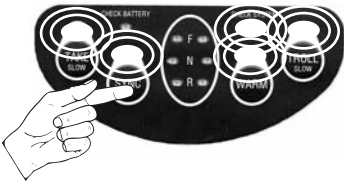
During operation, the system continuously monitors system functions and will alert operator if a system problem has been detected. When Alarm Mode is activated, control system will not continue to operate. In absence of control signal from the system, transmission will normally go to NEUTRAL and engine throttle will normally go to IDLE.

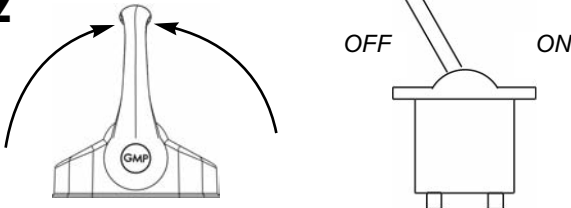
Step 1		ACTION	RESULT
<p>4-BUTTON KEYPAD</p> 	<p>2-BUTTON KEYPAD OR ITC KEYPAD</p> 	<p>All 4 lights on the control head keypad are blinking in unison</p>	<p>System will NOT operate. Transmission will normally go to Neutral and engine throttle will normally go to Idle.</p>
Step 2		<p>Return the main station control handles to NEUTRAL and turn power switch OFF</p>	<p>Restart the system.</p>

If the system remains in Alarm Mode after restarting the system, the operator should investigate the cause of the alarm (see Section 6.0 — Troubleshooting Mode). For vessels equipped with the optional backup system, this investigation may take place upon arrival at your destination. For boats NOT EQUIPPED with the optional backup system it is STRONGLY RECOMMENDED that the boat be securely tied at the dock, or the vessel should be in a safe place (free from shipping lanes) PRIOR to investigation of alarm codes.

3.0 Installing the Smart Actuator II™

Installing the Smart Actuator II™ is simple and easy. It is always important that proper care be given when installing any equipment on board your vessel. It is always a wise practice before cutting into the ship's interior to follow the old adage "measure twice, cut (or drill) once!"

The installation process includes the following:

- Section 3.1 — Pre-installation Planning
- Section 3.2 — Engine Compartment — Mount the Smart Actuator II™s
- Section 3.3 — Engine Compartment — Control Cable Connections
- Section 3.4 — Engine Compartment — Electrical Connections
- Section 3.5 — Mounting the Control Head

3.1 Pre-installation Planning

Before beginning the installation of the Glendinning Smart Actuator II™, proper consideration and pre-planning should be given to several very important parts of the control system. Proper planning of the installation will help to insure that the Smart Actuator II™ system will operate correctly and within specification. Failing to properly plan out the installation may decrease the reliability of the system. The following are the most important things to consider in planning. Close attention should be given to these issues:

● Smart Actuator II™ Location

Operational Clearances —The primary factor in choosing a location for the actuators is finding a location that results in the shortest, most direct path for the push-pull cable that connects the actuator(s) to the transmission and/or engine governor. In general, for engines where the control cable travels aft from the engine governor / throttle lever, the throttle actuator will be mounted in the aft section of the engine room. Conversely, for engines where the control cable heads forward from the engine governor lever, the actuator will be mounted toward the forward end of the engine room. The Smart Actuator II™(s) should NOT be mounted on the engine. In general, the length of the control cable from the actuator(s) to the transmission and engine governor should not be greater than 10 feet and 180 total degrees of bend. (Longer lengths may be used after review and approval of the physical layout of the product installation by Glendinning Marine Products).

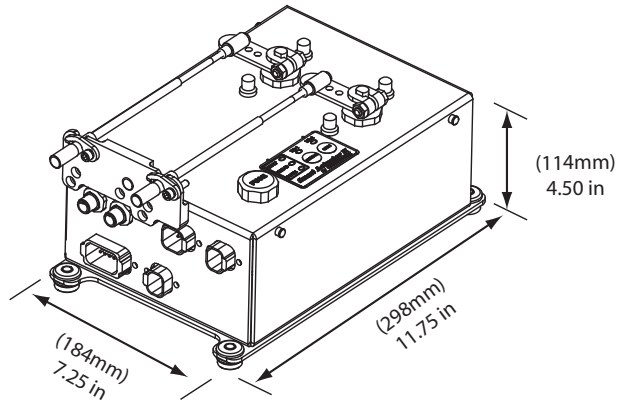

One reason why a short cable to the engine governor is critical has to do with engine synchronization. In order to accurately synchronize one engine to the other, it is necessary to position the governor with an accuracy of less than five thousandths (0.005") of an inch. Any unnecessary bend in the control cable to the governor lever, or using a cable that is longer than necessary, will result in lost motion between the actuator and engine, causing a reduction in synchronization accuracy.

Environmental conditions —The Smart Actuator(s) should be mounted in an area that is relatively dry and not excessively hot. Although the electronic components are reasonably well-sealed from moisture, the product enclosure is not designed for constant, direct contact with water. Since the longevity of electronic components is reduced in high temperature environments it is best to find an area of the engine compartment that is not exposed to temperature extremes. The Smart Actuator(s) has been designed for installation in the engine compartment, and should be mounted where there is some air movement or ventilation.

Accessibility — During system calibration or troubleshooting, it will be necessary for the installer or repair technician to have access to the connection points of the Smart Actuator(s). In view of this, the Smart Actuator should be mounted in a relatively accessible area.

● Power Supply / Enable Switch

In the installation of any electronic device, the source of power is one of the most important factors to consider during the installation. The Complete Control System has a unique and very reliable power supply system which, if the system is properly installed, greatly improves the overall reliability of the engine control system.

Dual Battery Input—The Smart Actuator(s) provide for the connection of two independent sources of DC power. During normal operation, the Smart Actuator(s) will draw power from both power sources. In a typical boat, the DC power distribution system is designed to take power from a single battery source and then distribute it to the various equipment that require power. Although the Smart Actuator(s) can be powered off the DC distribution panel, this is **NOT RECOMMENDED**

because it is not able to provide for the supply of power from 2 independent sources to any single device. In other boats, several batteries are arranged in parallel. Obviously, these batteries are not independent—that is, the voltage observed at one battery terminal will be the same at the other battery terminal. It is important that each battery source be completely independent of the other.

Power Source to Smart Actuator(s) Must be Uninterrupted—It cannot be overemphasized that providing a secure, uninterrupted source of power to the Smart Actuator II™ is vitally important to the reliable operation of the control system. For this reason, it is best that the power be drawn as close as possible to the battery positive terminal, without having various components which may interrupt the flow of current to the control system.

Circuit Protection / Enable Switch—Per the ABYC guidelines, some type of current protection—circuit breaker or fuse—must be installed within 7 inches (17cm) of the connection to the source of power. It is very important to understand that circuit protection is installed for the protection of the wire, not the Smart Actuator II™. The Smart Actuator II™ has its own internal current protection and does not need any external fuse. However, the wire which connects the Smart Actuator II™ to the boat power must be protected in case of chafing or other damage. In order to not limit power to the system during normal operation, a minimum 15 amp fuse or circuit breaker must be installed (if a 30 amp fuse or circuit breaker are used, then it is necessary that 10 AWG wire, or larger, is used to connect the Smart Actuator II™ to its power source). Since the fuse or circuit breaker is physically located in the engine compartment, it would be extremely inconvenient to require the boat operator to have to go to the engine compartment to start-up the Complete Control system each time the boat operator wishes to use the boat. For this reason, Glendinning has allowed for two ways to start-up the system: 1) the installation of an enable switch which allows the boat operator to remotely turn ON or OFF the Complete Control system from the helm station. When the enable switch is used, the Smart Actuator II™ circuit protection is typically left in the ON position. The enable switch only requires a small (2 conductor, 18 gauge) wire to be run from the engine compartment to the helm station. **DO NOT APPLY POWER TO THE ENABLE SWITCH**—The purpose of the enable switch is only to open or close the circuit which allows power to be applied to the control system. 2) the installation to ignition power inputs which allows the system to be activated when turning the engine keyswitches to the ON position.

Battery Ground—The dual battery system requires that the battery positive terminals be at roughly the same voltage. In order for the battery positive terminals to be at the same voltage, it is necessary that the negative terminals of the batter-

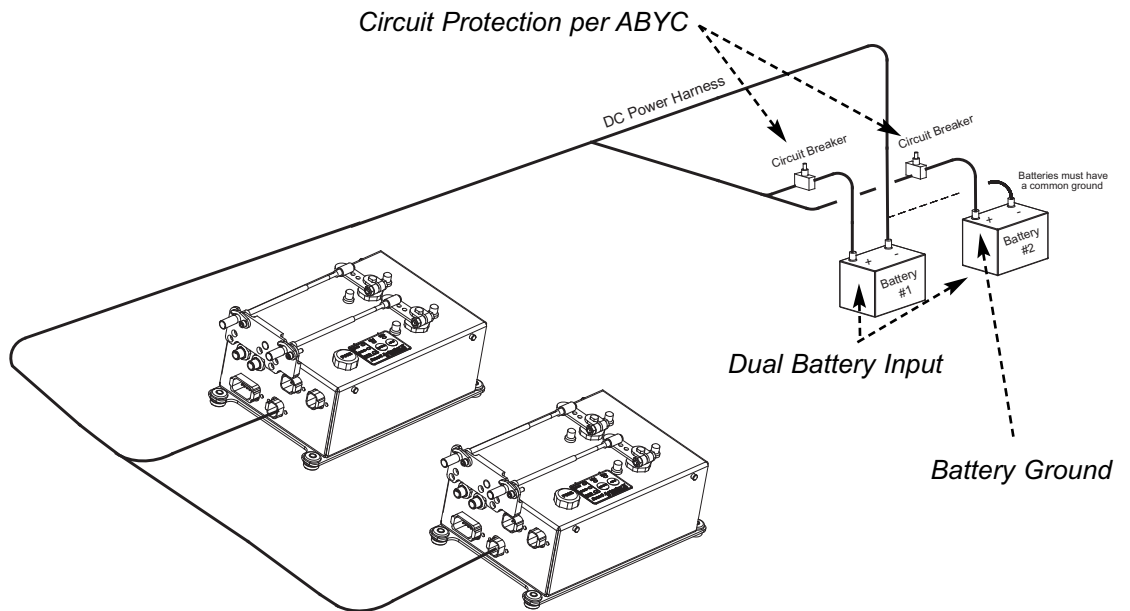

ies be connected at some common point. This is normal marine electrical practice and is specified in the ABYC guidelines. Prior to the final electrical hookup of the Complete Control system, the installer should verify that the battery ground terminals are connected at some common point.

● Station Communications Cable / Network Installations

The Complete Control System utilizes CANbus technology to communicate between the Smart Actuator II™ and the Control Station(s). Simply put, the CAN(Controller Area Network)bus network consists of a series of devices connected by a single wire routed throughout the boat. Station communication connects each system component sequentially which minimizes cable runs and lengths. At each end of the bus network a CANbus terminator (terminating resistor) must be connected in order for the system to perform correctly.

Station Communication Cable Routing—When routing Station Cables it is advisable to inspect the route and make sure surfaces are free of any sharp edges or burrs which could nick the cable and compromise the reliability of the system.

Connectors are pre-terminated at the factory and should NEVER be forced into their proper receptacle. Make sure that the connector is properly aligned prior to insertion into the receptacle. If the connector is properly aligned, only a small amount of force will be necessary to insert the connector into the Smart Actuator II™ or Control Head. Failure to properly align connector may damage the pins and cause the system to fail.

Connectors are one of the most important parts of the Complete Control system. Keep connectors covered and clean during installation. Most problems occur due to bad connections.



Terminating Resistor

● SMART ACTUATOR II™ System Layouts

Single Station Layout

Single cable connects control head to control processor.

Control Head must be installed for single engine applications

Terminating resistor installed at open communications port at control head.

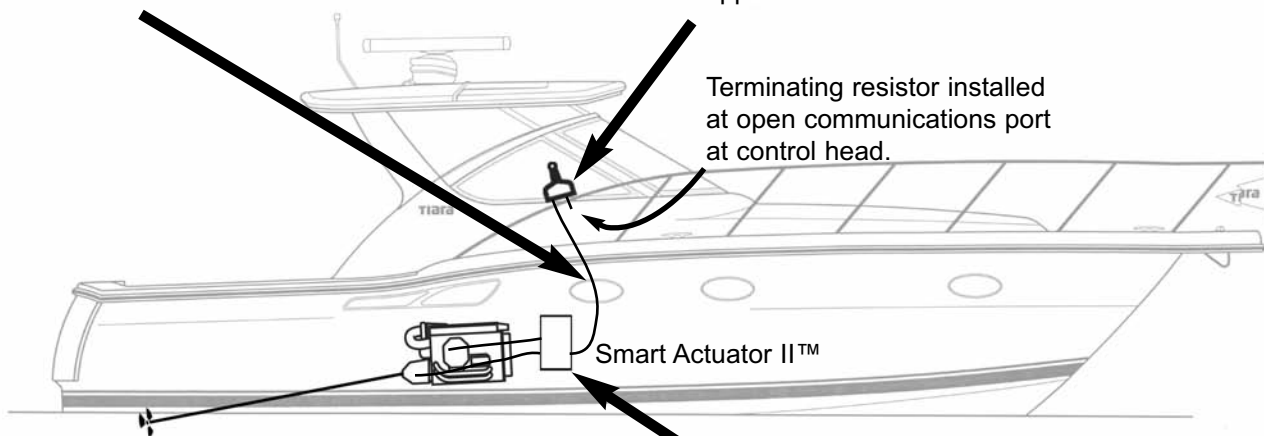

Terminating resistor installed at open communications port at Smart Actuator II™.

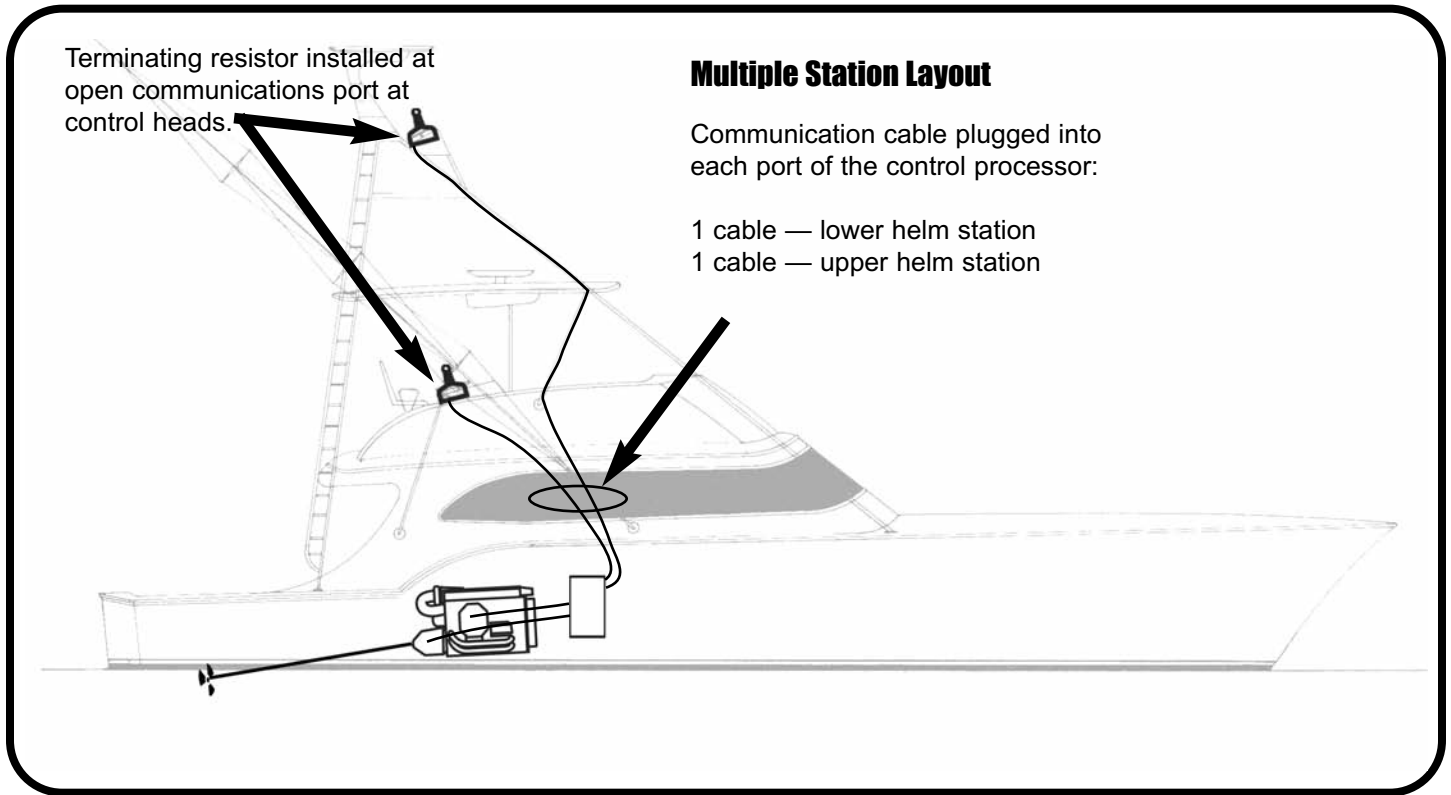

3.2 Engine Compartment — Mount the Smart Actuator II™

The Smart Actuator(s) can be mounted anywhere in the engine room providing that the Actuator(s) is reasonably accessible so that inspection and/or repairs to the unit, and connection of throttle and/or gear control cables may be performed. The Smart Actuator II™ should NOT be installed in adverse locations subject to saltwater exposure or excessive heat, or vibration — DO NOT MOUNT ON THE ENGINE.

STEP 1: Once the proper location for the mounting of the Smart Actuator II™ has been determined (see Pre-Installation Planning section 3.1 for guidelines), mount the Smart Actuator II™ using (4) 1/4" (7mm) machine bolts or lag screws. If using lag screws, screw length should be no less than 1-1/2" (38mm). If using machine bolts, lockwashers or locknuts MUST be used.

A larger version of this drawing appears in the Appendix section

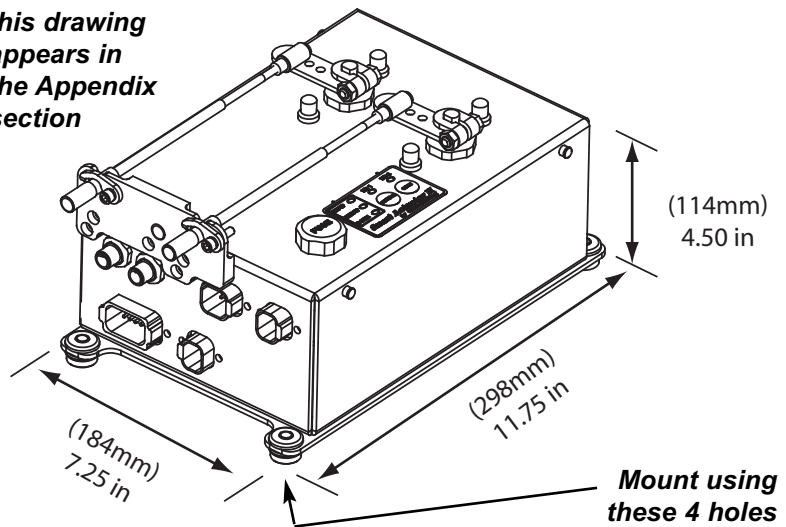

3.3 Engine Compartment — Control Cable Connections

A. Using the control cable swing clamp, mount the throttle / gear / troll lever control cables in their respective locations on the engine and transmission. Mount cables - do not connect the cable ends to the control levers at this time (NOTE: Although 43c cables can be installed with our system, we recommend premium grade, Type 33C control cables as

the best cable choice).

B. Install swivel ball joints on the end of each control cable, ensuring that you have at least 1/2" (13 mm) of thread engagement. Do not tighten the cable jam nuts yet.

NOTE

In some cases, sufficient over-travel will not be able to be obtained even with adjustment of the cable clamp holder. This is caused by the connection point on the engine or transmission lever (normally called the pivot pin) being too far away from the shaft that the lever is connected to. In these cases, the pivot pin will have to be moved closer to the shaft (the "fulcrum point") in order to shorten the pivot pin travel. This will give you the correct over-travel required. The recommended length of travel of the control lever pivot pin should be approximately 2-1/2" to 2-3/4".

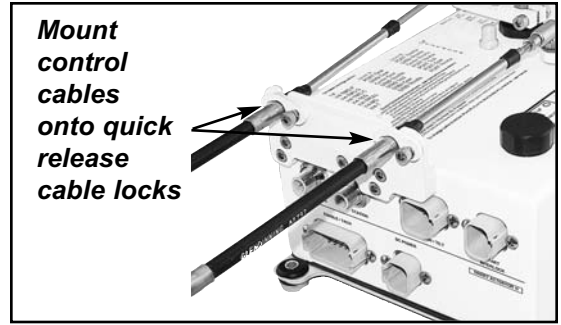

C. Compare the travel of each control cable to its associated lever at the transmission and engine. Ensure that each control cable has "over-travel" or that the cable is able to travel farther than the lever that it will be attached to. Check this for both ends of travel. If the control cable will not "over-travel" in both directions, adjustments will have to be made:

- If 1/4" or less adjustment is required, the terminal eye on the end of the cable may be screwed on or off the cable end. Ball joint thread engagement on the control cable end must never be less than 1/4".

- If more than 1/4" inch adjustment is necessary to achieve correct over-travel, the cable clamp position on the engine or transmission will have to be moved.

Once correct control cable over-travel is verified, connect the terminal eye of each control cable to the engine governor / throttle and transmission lever and install the pivot pin cotter pins or clips. Tighten the control cable terminal eye jam nuts.

D. After the control cable terminal eyes are attached to the control levers on the engine governor and transmission, measure the amount of travel for each control cable. Do this measurement at the actuator end of the control cable. (This is the distance that the cable will travel when the engine or transmission control lever is moved from one mechanical stop to the other. Record the information below - this information is needed in order to determine the correct cable connection on the Actuator coupler plates.

PORT ENGINE		STARBOARD ENGINE	
CONTROL CABLE	LENGTH OF TRAVEL	CONTROL CABLE	LENGTH OF TRAVEL
Throttle		Throttle	
Gear		Gear	
Troll Valve		Troll Valve	

E. Mount the engine / transmission control cables to the actuator by removing the two screws that hold the locking clamp in place. Make sure that the control cables are seated properly in the mounting location and replace the locking clamp and screws.

F. Select the correct Actuator cable lever connection hole to be used, depending on length of control cable travel.

G. Move the ball joint ball pin on Actuator plate to the correct actuator travel.

H. Adjust control cable terminal prior to attaching to Actuator coupler plate. Leave the control cables disconnected until you are ready to proceed with Smart Actuator II™ Calibration (Section 4.0).

3.4 Engine Compartment — Electrical Connections

A. Battery Power Supply Connections to the Actuator(s) & Bonding Wire

In the installation of any electronic device, the source of power is one of the most important factors to consider during the installation. The Glendinning Electronic Engine Control has a unique and very reliable power supply system which, if the system is properly installed, greatly improves the overall reliability of the engine control system. *NOTE: The Smart Actuator II™ can use 12 or 24V DC power, however, see the specific wiring diagram (see sec 7.1, or supplied by GMP technician) for the correct power to use. In some installations it is required to use 24V DC instead of 12V DC.*

The Glendinning Smart Actuator II™ system is equipped with a sophisticated power management system that allows it to receive power from two (2) independent batteries (normally the port and starboard engine start batteries). In normal operation, the Smart Actuator II™ will receive power from both battery sources, taking power from each battery proportionate to the voltage from level available. In the event of loss or reduction of voltage from one battery source, such as during engine start, the Smart Actuator II™ system will continue to function normally by receiving power from the other battery with normal voltage.

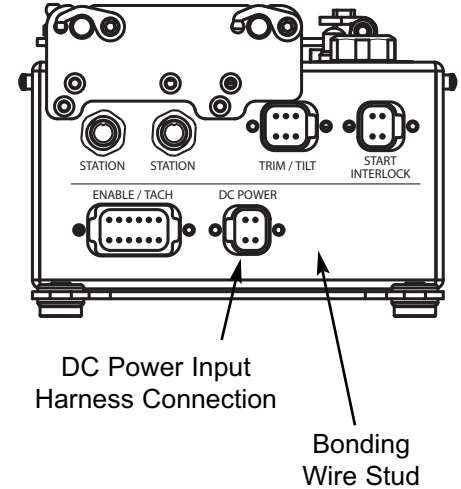

1) Connect the Smart Actuator II™ DC Power Harness (supplied) to two (2) independent battery sources, (normally the port and starboard engine start batteries). On the positive side of these two runs, install a 15 amp circuit breaker near each battery or power source (follow ABYC standards which require a circuit protection device within 7" of the wire connection to the power source — NOTE: If the total wire run is longer than 15 feet from the battery to the Control Processor, install an approved junction box that the DC Power Cable may be connected to).

2) Make sure that the breakers are in the OFF position and then connect the "DC Power" to the Control Processor where indicated (see Sec. 7.1-Wiring Diagrams).

3) Run a bonding wire (#12 AWG, green jacket) from the Smart Actuator II™ bonding stud (1/4"), located on the connector side of the unit, to the vessel's bonding strip.

B. Remote Enable Switch

While the boat is tied up at the dock and not in use, it is recommended that the Smart Actuator II™ system be turned OFF. Since power is normally supplied directly to the Smart Actuator II™ from power sources in the engine room, turning power ON and OFF in the engine room may be difficult to do each time the system is started up. For this reason, Glendinning provides two methods for the start-up of the Smart Actuator II™: 1) a **Remote Enable Switch** is available for use with the Smart Actuator II™ control system. This enable switch allows power to the system to be turned ON or OFF at the Main station; or 2) the installation to ignition power inputs which allows the system to be activated when turning the **engine keyswitches** to the ON position.

The Smart Actuator II™ System **Enable Switch** is installed as follows:

1. Make sure the circuit breakers that control the power to the Smart Actuator II™ is turned OFF before starting this installation.

2. Install a Single Pole, Single Throw (SPST) switch in the instrument panel. GMP has a switch/nameplate assembly designed for this purpose. The switch features a locking rocker that eliminates inadvertent activation of the switch. *NOTE: If installing a switch other than GMP's, locate the switch in an area where it will not be inadvertently turned OFF during*

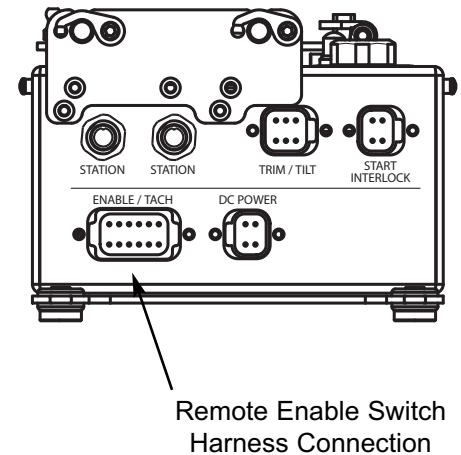

operation.

3. Connect switch to harness provided.

NOTE: Do not connect an indicator light to the remote enable switch connections.

NOTE: A "jumper" can be installed in the place of wires on the connector at Smart Actuator II™. Power may then be turned OFF and ON by using the 15 amp breakers installed at battery input.

Smart Actuator II™ Control System Wiring Diagram - Remote Enable Switch Standard - "Dry Contact" ON/OFF

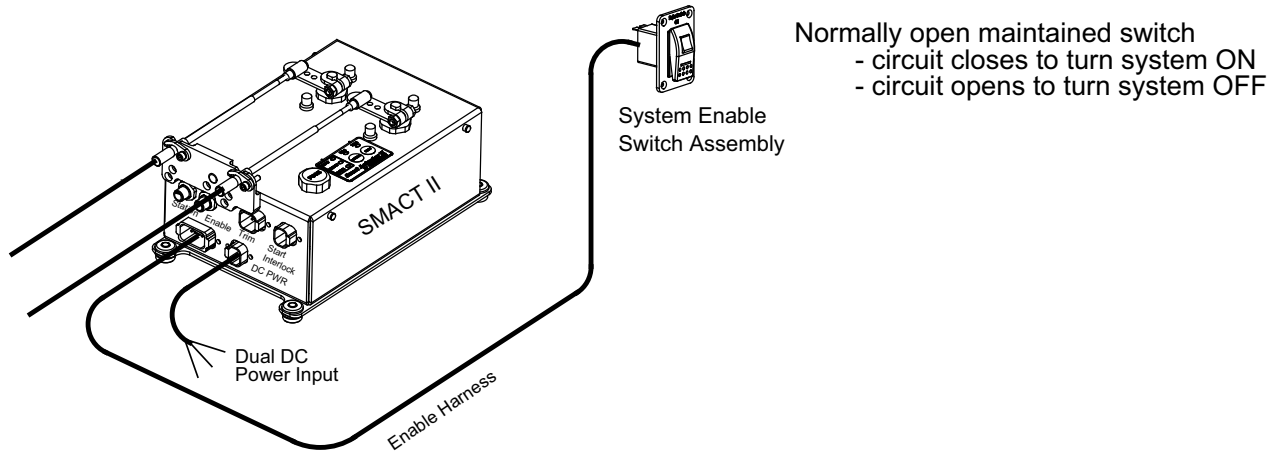

To enable the Smart Actuator II™ from the **ignition keyswitches**, follow these instructions:

1. Make sure the circuit breakers that control the power to the Smart Actuator II™ is turned OFF before starting this installation.
2. Insert the 12-pin Deutsch connector from the Enable Ignition Input Harness to the Enable / Tach port on the Smart Actuator II™ — You should hear an audible "click".
3. Connect the other end of the Enable Ignition Input Harness to the 12V or 24V contacts for the PORT and STBD keyswitches.

Ignition Activated - DC Power from both ignition keys

- DC power from either ignition key turns system ON, both must be off for system to turn OFF.
- Jumper switches select 12 or 24v DC control

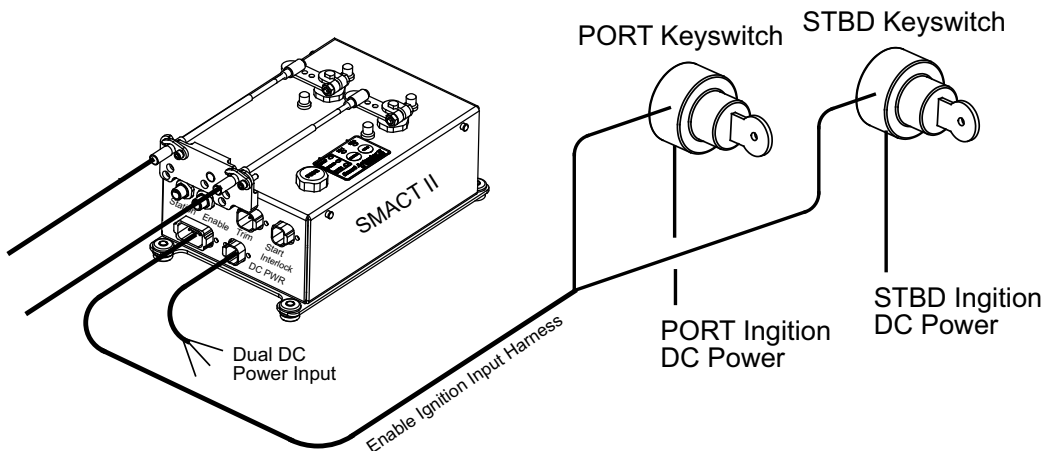

C. Start Interlock

The Smart Actuator II™ system includes a “start interlock” safety feature — this feature verifies that the transmission control lever is in Neutral prior to starting the engines. In order to utilize this product feature, the signal wire from the helm station start switch to the engine starter solenoid must be intercepted and run through the control switches within the Control Processor.

To install the Start Interlock system:

- 1) Connect the Smart Actuator II™ Start Interlock Harness (supplied) to the appropriate connector labeled “Start Interlock” on the Smart Actuator II™.
- 2) Route these wires to the engine distribution box and connect using appropriate connectors (see Sec. 7.1 - Wiring diagrams).

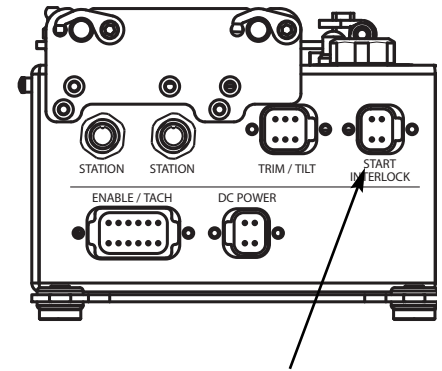

Start Interlock Harness Connection

D. Tachometer Inputs

There are four ways to provide RPM information to the Smart Actuator II™ system. This information is used by the system during engine synchronization.

1) **Open Loop Sync** — when the system is running WITHOUT RPM information being supplied to the Smart Actuator II™, the system will try to match handle position as accurately as possible during SYNC Mode. This accuracy will largely depend on how well cable adjustments are made during installation of the control cables. When the SYNC Mode is activated using Open Loop Sync, the SYNC LED will be flashing continually.

2) **Magnetic Pickup Interface (MPI)** — the Magnetic Pickup Interface is a magnetic sensor that is installed into the flywheel housing of the engine so that the gear’s teeth pass the end of the sensor generating a voltage pulse. The sensor “picks up” this voltage pulse (RPM information) and relays it to the Smart Actuator II™ through the use of a special harness. The RPM information is then used by the Smart Actuator during engine synchronization. Follow the instructions below for installation of the Magnetic Pickup Interface (MAKE SURE ENGINE WILL NOT OPERATE DURING INSTALLATION):

Step 1 — Drill or tap a hole in the flywheel housing (IMPORTANT: Drilling too deep may damage ring gear teeth. Blow chips with air hose when drilling and tapping hole). Insert the Magnetic Pickup sensor into the hole. BE CAREFUL not to exceed the recommended gap between the sensor tip and the flywheel. It is suggested to tighten the sensor until it touches the flywheel, then back off the sensor a quarter or half turn (consult your magnetic pickup sensor’s documentation for appropriate gap space). Check gap clearance by rotating the gear completely around. After adjusting set lock nut (Fig. 1).

Step 2 — Run wires from the Magnetic Pickup sensors from both PORT and STBD engines to the MPI Box supplied by Glendinning. Always use two-conductor shielded cable (NOTE: Never run these wires next to spark plug wires or in wire loom with other wires carrying

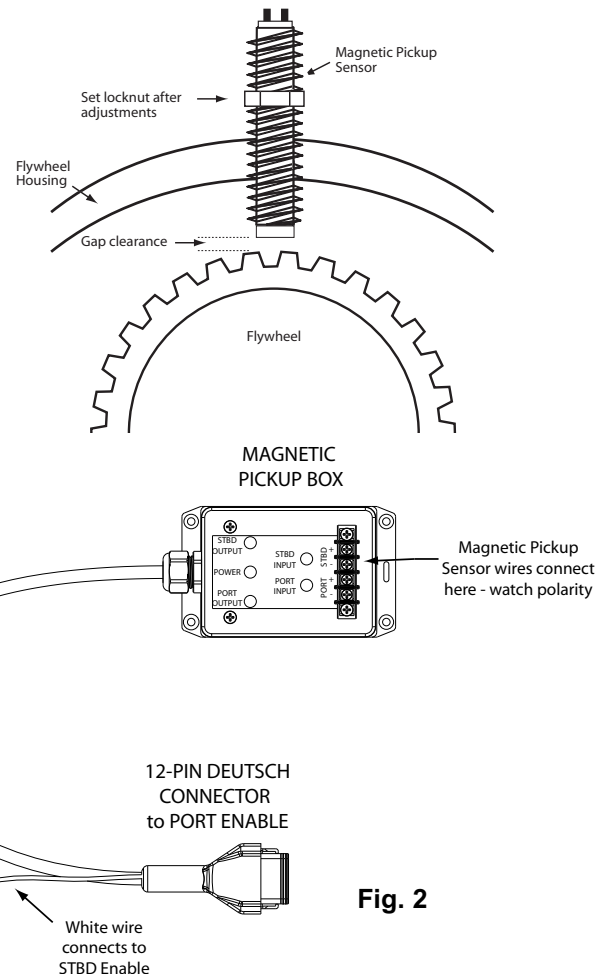

Fig. 1

Fig. 2

inductive loads or alternating current). Ground the shield to a metal frame ground at the engine end only. BE CAREFUL to observe correct polarity when installing these wires onto the barrier strip of the MPI Box (Fig. 2).

Step 3 — Install the 12-pin Deutsch connector to the Enable / Tach plug on the PORT Smart Actuator II™. Push the connector all the way in until you hear an audible click.

Step 4 — Install the white “jumper” wire from the 12-pin Enable connector to the STBD Enable connector using a butt connector.

3) **Tach Senders** — Installation of the tachometer senders is relatively straightforward. The following points should be considered:

- Only tachometer senders that are supplied by GMP are to be used with the Smart Actuator II™ system.

- On engines equipped with mechanical tachometer outlets, such as Detroit Diesel, Caterpillar 3208, MAN, etc. the tach senders may be directly connected to the tachometer outlet on the engine. The tach senders that are supplied by GMP are “in-line” senders; that is, they may be installed between the engine tachometer connection and any other tachometer senders or tachometer drive cables that are attached to that tachometer connection.

- On engines that are not equipped with a tach sender outlet, such as Volvo Diesel or any gasoline engine, a mechanical tachometer adapter will have to be used.

- The tach senders must be driven at a speed that corresponds to 1/2 engine speed. This is normal on most engines that have mechanical tachometer outlets or that use a mechanical drive adapter. On some engines, it may be possible to drive the tach sender at 1:1 or even twice engine speed. If this is done, the Engine Processor will be damaged due to excessive voltage output from the tach sender. To check for excessive tach sender speed, set your meter on frequency or hertz, verify that at full open the frequency is no larger than 5000 hz. (If you cannot check frequency, check the voltage from the tach sender while the engine is running at full speed. No more than 18 VAC should be present at the tachometer sender terminals.)

Wiring the Tachometer Senders to the Smart Actuator II™:

Connect the Black and Black w/ red stripe wires from the Tachometer Sender to the Smart Actuator II™ PORT Harness / Electric Gear Enable Harness / or the Center Engine Harness (see pgs. 48-49, & 52). **DO NOT CONNECT ANYTHING ELSE** to these wires (the other wires, yellow and red, may be used to drive other tachometers and related equipment).

4) **Direct Connection** — in some applications (such as outboards, etc.) the RPM signal may be picked up directly from the tachometer. Contact GMP for specific applications and instructions.



E. Station Communication Cable Connections

Review comments made in Pre-Installation Planning, paragraph 12, for determining proper routing of cables. Cables are manufactured in 20' increments and are available from 20 - 120 feet.

When routing and connecting station communication cables, BE SURE TO DO THE FOLLOWING:

- Use a terminating resistor at each end of the bus.
- Align the cables before connecting them to the proper connector on the Control Head and/or Smart Actuator II™(s).

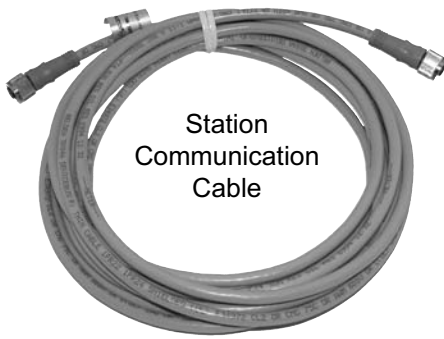

Station Communication Cable



Align notch properly before inserting

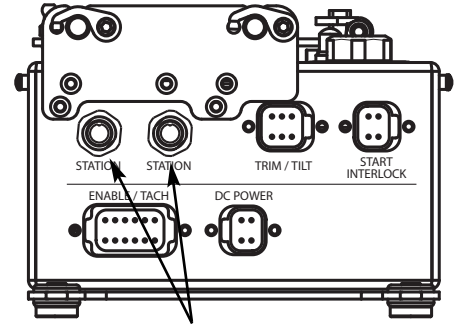

Station Communication Cable Connections



It is VERY IMPORTANT that the Station Communication cable not be connected tightly. The nut requires 6-7 turns to completely connect it, and there should be no more than a 2mm (1/16 inch) gap between the nut and the connector — see diagram below.

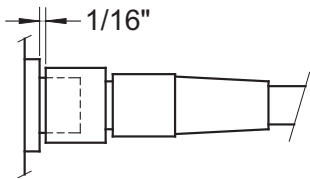

WARNING: Failure to follow the instructions above will result in erratic system performance.

Station cables MUST NOT be spliced or shortened in the field. Cutting or nicking the cable will compromise the reliability of the system!

F. Solenoid Gear Interface Box (optional)

The Solenoid Gear Interface Box communicates information necessary for the control of the Smart Actuator II™(s) and your boat's solenoid controlled transmissions. The components of the Solenoid Gear Interface Box are:

- DC Power Harness
- Gear Harnesses (Port & Starboard)
- Start Interlock Harness
- Interconnect Harness

Installation of the Solenoid Gear Interface Box is very easy and requires two main steps. They are:

STEP 1: Mount the Interface Box near the Smart Actuator II™ using (4) screws. An ideal location would be next to the Smart Actuator II™ directly under the control cables as they leave the Actuator.

STEP 2: Connect the various harnesses (see below):

a. **DC Power Harness** — The DC power harness for the Smart Actuator II™ comes equipped with two connectors. One connector plugs into the proper receptacle on the Smart Actuator II™. The other connector plugs into the appropriate labeled receptacle on the Solenoid Gear Interface Box (order PN 11601-02).

b. **Gear Harnesses** — One end of the the Port and Starboard Gear Harnesses is connected to the Solenoid Gear Interface Box in the properly labeled receptacles. The other end is connected to the appropriate (Port or Starboard) gear solenoid on your engines.

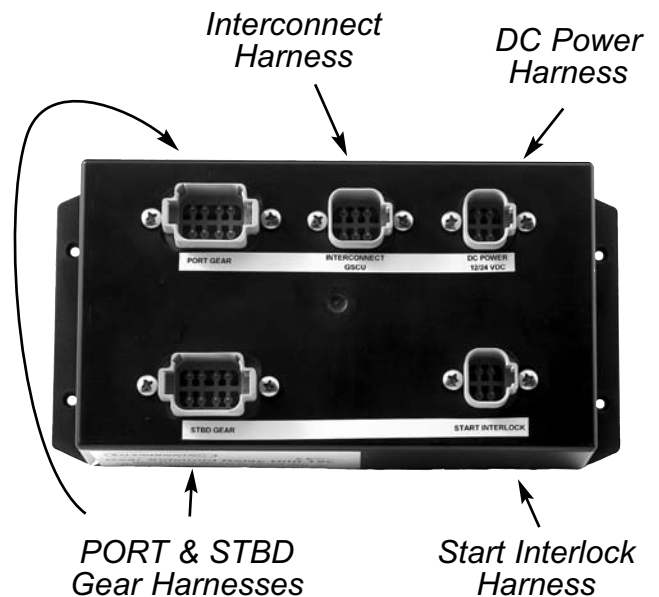

c. **Start Interlock Harness** — The Start Interlock Harness should be connected to the appropriate labelled connector on the Interface Box and the engine starter solenoid.

d. **Interconnect Harness** — Normally 1' long, this cable connects to the 6 position connector on the Smart Actuator II™ and the Solenoid Gear Interface Box.

3.5 Mounting the Control Head

One of the most important factors in selecting control head locations is the ability to control the vessel by allowing FULL movement of the control head handles. The area around the control head should have proper drainage to eliminate standing water. Although the control heads are sealed to withstand damage from exposure to moisture, they are not designed to be submerged.

There are two types of control heads available with the Smart Actuator II™ system — they are the CP control head and the remote station control head. Both the CP and remote station control heads perform all functions necessary for the control of your boat's propulsion system. The CP control head also includes the necessary components built-in for communication between all control stations along the CANbus network and the Smart Actuator II™. For single station applications you will only need the CP control head. For multiple station applications you are required to have (1) one CP control head and the other control heads may be the remote station control heads.

REFER TO APPENDIX FOR DIMENSIONAL DRAWINGS FOR ALL TYPES OF CONTROL HEADS. Allow an additional 2.0 inches of clearance below control head for the insertion of station communication cables or terminating resistors.

STEP 1: Mark the location for the Control Head using the template provided (see Sec. 7.2 -Dimensional Drawings / Cutout Templates). Cut the 3-3/8" x 4-7/8" hole.

STEP 2: Place the Control Head assembly into the cutout. The Control Head clamps, which hold the control head against the console, have a break off point indicated by a perforation. For consoles 1/4" to 1" thickness, use bracket as supplied. For 3/4" to 1-5/8" thickness, break off clamp at 3/4" break off point.

STEP 3: Install Control Head clamps and tighten wing nuts provided. Make sure Control Head is firmly mounted to console.

NOTE: 10.5 inches clearance needed for operation of control handles

NOTE: Allow additional 2" of clearance below all control head types for the insertion of cable connections and/or terminating resistor (shown)

See Appendix for dimensional drawings for different control head types

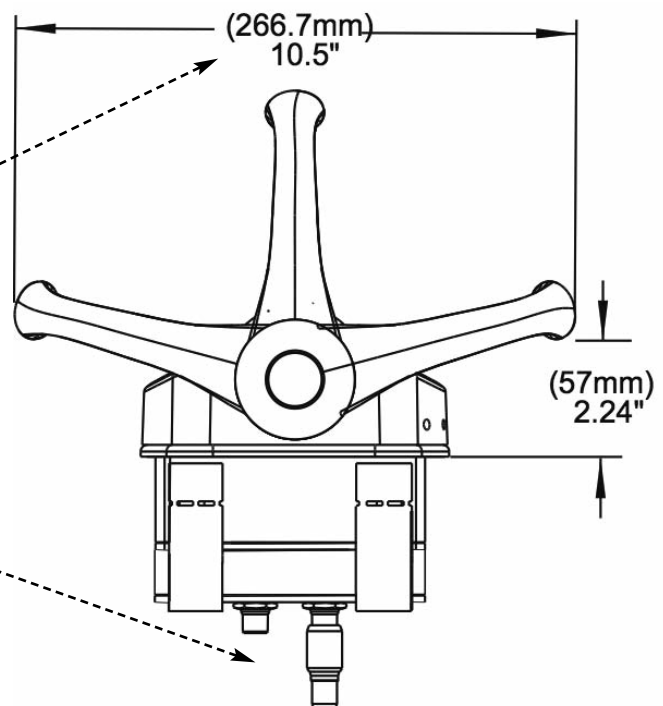

3.6 Integrated Trim Control (optional)

A. Description

One of the key features of the Glendinning Smart Actuator II™ Control system is the Integrated Trim Control (ITC™) option. The ITC™ option features CANbus connections for easy integration into an existing Smart Actuator II™ system.

In essence, the Smart Actuator II™ control system permits control of the trim / tilt of the engine's drive unit through electronic signals sent from the operation of the dedicated switches on the control head.

Trim control is obtained by one of two methods:

Control Head Handle Rocker Switch — by far the easiest way to control your trim is by utilizing the built-in rocker switch on the control head's handle. When in operation, simply depress the switch either up or down to affect BOTH PORT and STBD side trim.

Dedicated Control Head Keypad Buttons — dedicated buttons on the ITC keypad allow you to set each engine's trim individually. Pressing the PORT trim button only affects PORT side trim. Pressing the STBD trim button affects STBD side trim.



B. Operation

Under normal operations, the gear and throttle are controlled by the movement of the control head handles and keypad button presses. **Operational functions of the keypad buttons are the same as the 2-button Control Head keypad** (see Section 2.0 - Operating the Smart Actuator).

When more or less trim is desired, the operator will press the rocker switch on the control head handle in the appropriate direction. Both PORT and STBD trim will move to the corresponding movement of the trim control switch.

If more precise, individual trim of each side is desired, press and release the trim control buttons on the ITC keypad in the appropriate direction (UP or DWN). Trim control may take place when the boat is in gear and above IDLE.

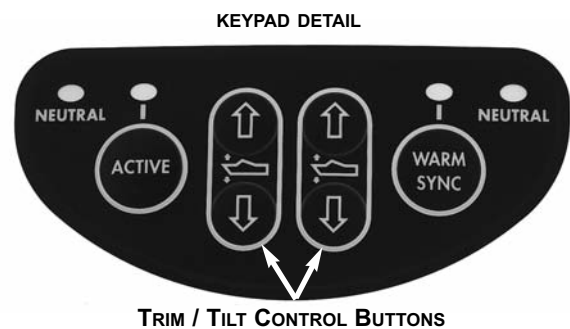

C. Installation

There are two steps for installation of the ITC™ control system. They are:

- 1) Install the ITC™ Control Head
- 2) Connect the ITC™ Harness to the Smart Actuator II™ and your boat's trim system components.

1) INSTALL THE ITC™ CONTROL HEAD — One of the most important factors in selecting control head locations is the ability to control the vessel by allowing FULL movement of the control head handles. The area around the control head should have proper drainage to eliminate standing water. Although the control heads are sealed to withstand damage from exposure to moisture, they are not designed to be submerged.

STEP 1: Mark the location for the Control Head using the template provided (see Sec. 7.2 -Dimensional Drawings / Cutout Templates). Cut the 3-3/8" x 4-7/8" hole.

STEP 2: Place the Control Head assembly into the cutout. The Control Head clamps, which hold the control head against the console, have a break off point indicated by a perforation. For consoles 1/4" to 1" thickness, use bracket as supplied. For 3/4" to 1-5/8" thickness, break off clamp at 3/4" break off point.

STEP 3: Install Control Head clamps and tighten wing nuts provided. Make sure Control Head is firmly mounted to console.

*NOTE: In order for each Control Head to communicate with the Smart Actuator II™, each Control Head must have a unique Handle Identifier. If you purchased a complete system, configuration and handle identification was performed by the factory. If you purchased a control head **separately**, you will **NEED** to set the handle identifier for that control station. Follow the instructions in Section 7.4 — Setting Handle ID.*

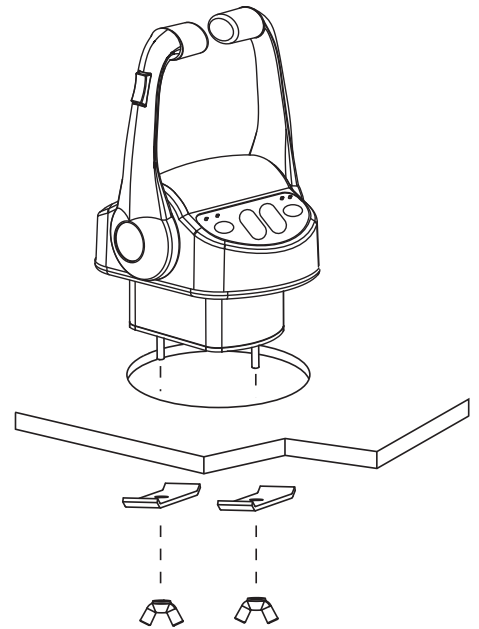

2) CONNECT THE ITC™ HARNESS — The ITC™ Harness relays the signal from the control head switches to the trim motor. Insert the connector end of the ITC™ harness into the appropriately labeled connector on the Smart Actuator II™ until you hear an audible “click”. Using the correct connectors for your type of trim motor connection, attached the other end of the harness to your trim pump.

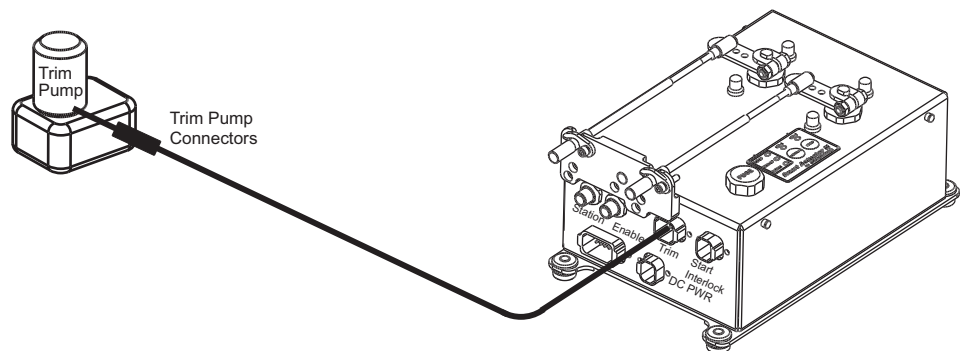

ITC™ HARNESS CONNECTION AT SMART ACTUATOR II™

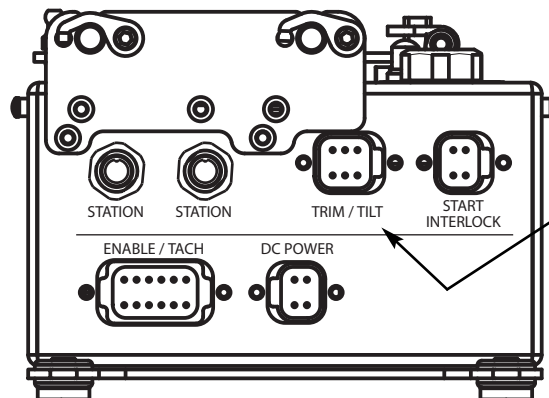

4.0 Smart Actuator II™ Endpoint Calibration

The Smart Actuator II™ Endpoint Calibration Mode allows you to change settings for the Smart Actuator II™ so that it will perform correctly with the boat's propulsion system. The Smart Actuator II™ Endpoint Calibration Mode is in two sections:

Section 4.1 — Calibrating the Actuator Endpoints & Cable Directions

Section 4.2 — Setting the Cable Direction only (if endpoints have already been calibrated and only cable direction needs changing).



**DO NOT CONNECT PUSH - PULL CABLES TO THE ACTUATORS
PRIOR TO CALIBRATING ACTUATOR ENDPOINTS AND CABLE DIRECTION!**

The Smart Actuator II™ receives electronic impulses from the control head which moves the actuator plates into a position where the associated engine's gear or throttle control lever has reached its mechanical stop position (endpoints) — see Figure 1. Calibration of the Smart Actuator II™ endpoints is necessary to ensure that the engine achieves idle speed or full throttle when moved by the Smart Actuator II™.

It is important to find the proper balance between the control cable position being "too loose" and not reaching its endpoint position (and therefore the engine not achieving idle speed or full throttle), and the cable being set up "too tight" and constantly operating in a compressed or stretched condition when moving to its endpoint of travel. Calibrating the Smart Actuator II™ with this proper balance will yield trouble-free operation of your engine's propulsion system.

To calibrate the actuator endpoints it will be necessary for you to follow the instructions in the chart (Section 4.1) on the following pages.

Prior to configuration of the Smart Actuator II™, it is vital to determine the actual direction of travel of the control cables that connect to the engine governor and transmission control levers. Circle the appropriate direction on the charts below:

TRANSMISSION GEAR LEVER MOVEMENT

PORT ENGINE		STARBOARD ENGINE	
To engage	PUSH	To engage	PUSH
AHEAD	OR	AHEAD	OR
gear:	PULL	gear:	PULL

ENGINE GOVERNOR LEVER MOVEMENT

PORT ENGINE		STARBOARD ENGINE	
To	PUSH	To	PUSH
INCREASE	OR	INCREASE	OR
engine	PULL	engine	PULL
speed:		speed:	

To continue with calibrating Actuator Endpoints and setting Cable Direction, follow the instructions on the following page.



**CAUTION: KEEP HANDS AWAY FROM MOVING COMPONENTS OF
ACTUATORS WHEN CALIBRATING ENDPOINTS!**



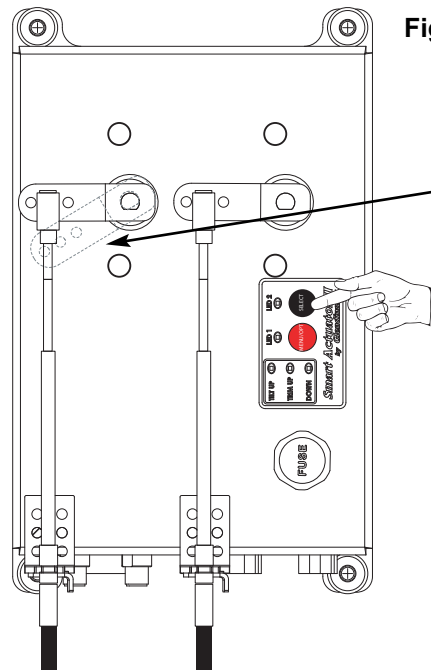
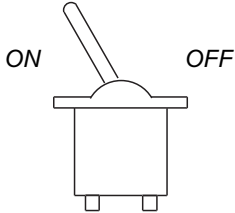
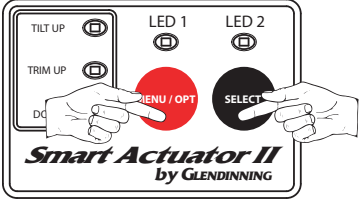
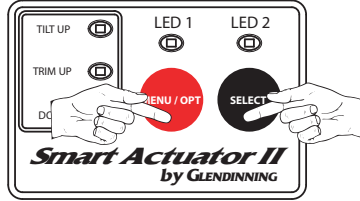
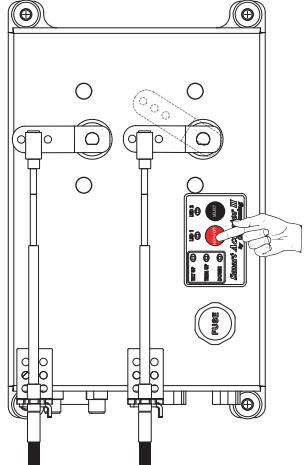
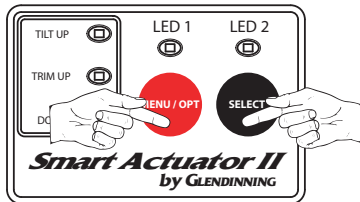
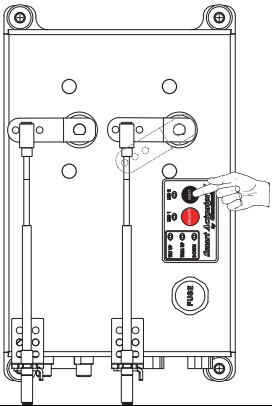
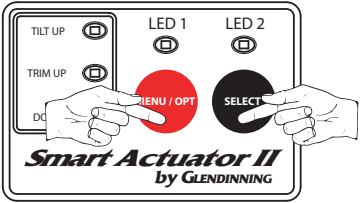
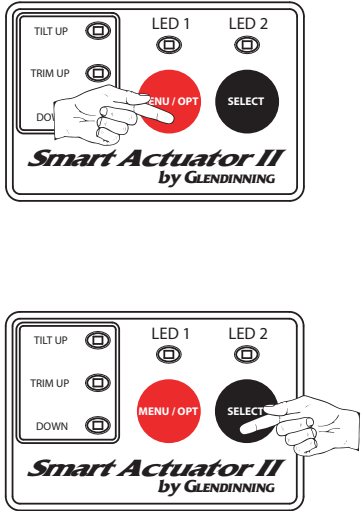
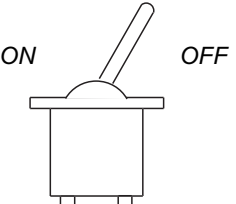

Fig. 1

Actuator Coupler Plate is moved to mechanical stop position (endpoint).

4.1 To Calibrate the Actuator(s) Endpoints & set Cable Direction, follow these steps:

1	ACTION	RESULT
	<p>Turn power to Smart Actuator II™s ON</p>	<p>N/A</p>
<p>2</p> 	<p>Press & Release both the RED & BLACK buttons on the Smart Actuator II™ simultaneously 3 times</p>	<p>Both LEDs above the RED and BLACK buttons will flash to indicate that you have entered Smart Actuator II™ Configuration Mode</p>
<p>If calibration of the Throttle Actuator (LEVER 1) is desired, continue with the steps below.</p> <p>If calibration of ONLY the Gear Actuator (LEVER 2) is desired (but NOT LEVER 1), then PRESS & RELEASE the RED button 1 time BEFORE continuing with the steps below.</p>		
<p>3</p> 	<p>Press & Release both the RED & BLACK buttons simultaneously on the Smart Actuator II™ 1 time</p>	<p>Both LEDs above the RED and BLACK buttons will go OUT — this indicates that you are ready to calibrate the Actuator endpoints</p>
<p>4</p> 	<p>Press & Release the RED button repeatedly to EXTEND LEVER 1 to the desired position — if you extend the piston too far you may PRESS & RELEASE the BLACK button to RETRACT to the desired position</p>	<p>You may also Press & HOLD down the RED button to extend LEVER 1 in larger increments until the desired position is achieved.</p> <p>Be careful to RELEASE button when endpoint is achieved!</p>
<p>5</p> 	<p>Press & Release BOTH the RED & BLACK buttons simultaneously 1 time to confirm LEVER 1 extended position</p>	<p>The LED above the RED button will illuminate to indicate that extended piston position is saved in memory.</p>

<p>6</p> 	<p>ACTION</p> <p>Press & Release the BLACK button repeatedly to RETRACT LEVER 1 to the desired position — if you extend the piston too far you may PRESS & RELEASE the RED button to EXTEND to the desired position</p>	<p>RESULT</p> <p>You may also Press & HOLD down the BLACK button to retract LEVER 1 in larger increments until the desired position is achieved.</p> <p>Be careful to RELEASE button when endpoint is achieved!</p>		
<p>7</p> 	<p>Press & Release BOTH the RED & BLACK buttons simultaneously 1 time to confirm LEVER 1 retracted position</p>	<p>BOTH LEDs above the RED & BLACK buttons will illuminate to indicate that retracted piston position is saved in memory.</p>		
<p>8</p> 	<p>IMPORTANT</p> <p>Press the RED or the BLACK button to confirm correct travel direction for LEVER 1:</p> <p>For PUSH to OPEN / AHEAD — press & release the RED button</p> <p>For PULL to OPEN / AHEAD — press & release the BLACK button</p>		<p>LEDs ON</p>	<p>TRAVEL DIRECTION</p>
<p>1</p>		<p>LED 1 (above RED button)</p>	<p>PUSH direction</p>	
<p>2</p>		<p>LED 2 (above BLK button)</p>	<p>PULL direction</p>	
<p>If it becomes necessary to change the travel direction that has been entered during this procedure, refer to Sec. 7.6.4 for directions on how to ONLY set the cable travel direction for the Smart Actuator II™ without having to go through this entire calibration process.</p>				
<p>9 REPEAT steps 3 — 8 for LEVER 2 (Gear Actuator piston). NOTE: After completing Endpoint Calibration of LEVER 1 (Throttle Actuator), if endpoint calibration of LEVER 2 (Gear Actuator) is not required, you can proceed to step 10 (turn OFF power and restart).</p>				
<p>10</p> 	<p>Turn OFF power to the Smart Actuators and RESTART</p>	<p>You have successfully completed the calibration of the Smart Actuator(s). Proceed to Section 4.2 for Calibration Verification.</p>		

4.2 Endpoint Calibration Verification

Upon completion of the Endpoint Calibration procedure, it is advisable that the operation of the Smart Actuator II™ system be inspected to verify that each engine throttle and transmission lever is being properly moved in the correct direction and through the full range of travel. **Failure to do this can cause gear / transmission failure if the gear control lever is not moved into it's correct position.**



The following points should be kept in mind when verifying actuator position and operation:

Direction of travel - The location of engine idle and full throttle, gear ahead and astern, and troll valve lock-up / slip should be considered to ensure that the actuator is moving the engine and gear controls in the appropriate direction.

Actuator endpoint - The actuator should move its associated control lever to the mechanical stop without placing undue strain on the control cable or control lever.

Control lever detent position - When position the gear lever or trolling valve lever, it may be helpful to disconnect the push-pull cable from the lever and move the control lever independently from the system.

A suggested verification procedure follows:

1. Take control at any station that is convenient for good communication between the engine room and helm station.
2. With the station control levers (port and starboard) in the **neutral position**, verify the following for both engines and transmissions:
 - Engine governor - Idle position (mechanical stop)
 - Gear control lever - Neutral position
 - Trolling valve (if installed) - Lockup position (troll valve closed)
3. Move the station control levers (port and starboard) to the **ahead detent position**. Verify that both gear control levers have moved to the ahead position **and that the control cable is not binding**.
4. Move the station control lever (port and starboard) to the **astern detent position**. Verify that both transmission levers have moved to the astern position **and that the control cable is not binding**.
5. Move the station control lever (port and starboard) to the **full ahead and full astern positions**. Verify that both engine governors are at the full throttle (mechanical stop) position **and that the control cable is not binding**.
6. Move the station control lever (port and starboard) to the **neutral position**. Verify that both engine governors are at the idle (mechanical stop) position **and that the control cable is not binding**.
7. (Troll valve equipped boats only) - Move the station control lever (port and starboard) to the **neutral position**. Press and release the troll switch on the control. Troll switch light will illuminate indicating that troll mode is energized. Verify that both troll actuators have moved to troll valve open position **and that the control cable is not binding**.
8. (Troll valve equipped boats only) - Move the station control lever (port and starboard) to the **full throttle position**. Verify that both troll actuators have moved toward lockup position, but have not moved into the detented lock-up position **and that the control cable is not binding**.
9. (Troll valve equipped boats only) - Move the station control lever (port and starboard) to the **neutral position**. Press and release the troll switch on the control. Troll switch light will go out indicating that troll mode is off and that normal gear / throttle operation is available.. Verify that both troll actuators have returned to the lockup position **and that the control cable is not binding**.

After performing the Endpoint Calibration Verification, if you find that one actuator position needs to be changed, refer to the beginning of the Endpoint Calibration section and follow the instructions to re-calibrate the actuator endpoints.

This completes the calibration procedure. The electronic engine control system is now fully operational and ready for use.

5.0 System Test & Checkout

System test and checkout consists of 2 steps:

- 1) **Component installation checks** — verify that the components appear to be correctly mounted and installed.
- 2) **Operational tests** — make sure the system is operating correctly.

5.1 Component Installation Checks

A. Actuators

1.1	Verify Actuator(s) is securely fastened to boat structure.
1.2	<p>Verify electrical power connections:</p> <p><i>Battery Negatives</i>—Negatives from both batteries should be connected (not at Control Processor. It is vital that there be zero voltage potential between battery negative terminals. Battery negative terminals should be connected to Bonding system also.</p> <p><i>Negative Lead</i>—Negative wire from Smart Actuator II™ system is connected to single battery negative.</p> <p><i>Positive Leads</i>—Power should be connected from Battery positive terminal or disconnect switch (battery side of switch) to CP via 15 amp fuse / circuit breaker. Check that all battery connections are tight. Verify that Bonding Wire is properly connected to Bonding studs (see sec. 3.6).</p>
1.3	Verify that all connectors are properly inserted into their receptacles (Station Cables, Transmission Cables, Throttle Cables, and Troll Cables). DO NOT FORCE connectors into receptacles!. All wires should be secured with tie-wraps along route.

B. Control Head(s)

2.1	Verify Control Head(s) are securely fastened to boat structure.
2.2	Verify that Control Handles have an unobstructed freedom of movement (full ahead and full reverse).
2.3	Return all handles to NEUTRAL.

5.2 Operational Checks

A. General Functions

NOTE: While performing system checks, verify that the “Check System” LED stays OFF. If it comes ON, the system is in Alarm Mode (see Sec. 2.9) and alarm condition must be checked and corrected before proceeding.

B. Start Interlock

3.1	Turn System ON (see sec. 2.1).
3.2	Verify at the main station various functions: Warm up, Slow, Troll, Sync.
3.3	Transfer control to other stations (see sec. 2.7) and verify proper operation of functions at each station.

C. Power Inputs

4.1	Move Starboard Control Handle out of NEUTRAL position. Attempt to start engine. <i>(NOTE: Be prepared to immediately shutdown engine if start interlock has been wired incorrectly!)</i>
4.2	Engine should NOT start; if it does, start interlock has not been wired correctly. Fix wiring and re-check.
4.3	Move Starbord Control Handle back to NEUTRAL position. After handle is moved to NEUTRAL position, then try to start engine. Engine should start.
4.4	Perform same check for Port engine.

D. Engine Room Checks

5.1	To verify separate power inputs, turn ON individual breakers one at a time and verify that DC power (12 or 24 VDC) is supplied to the Control Processor.
-----	--

E. Trolling Valves (if equipped)

6.1	Gear Operation — Verify that transmission solenoid valves are turning ON and OFF as you move Control Handles into and out of gear. Make sure that transmission shifts into appropriate direction — pushing handle forward causes forward boat motion, etc.
-----	--

6.0 Enter Handle Troubleshoot Mode

If the system indicates an alarm or warning code is stored — to review the stored alarm codes you must first enter “Handle Troubleshoot Mode.” To do this you must use the main station control head and follow the 4 simple steps below:

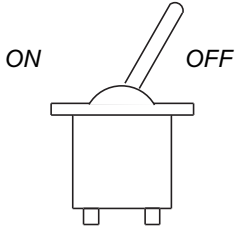
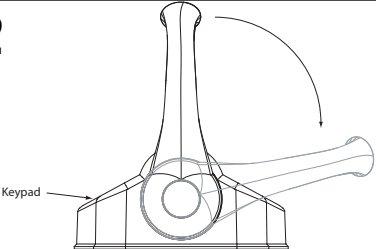
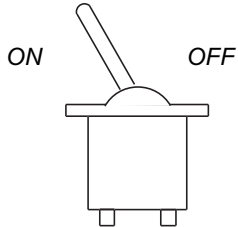
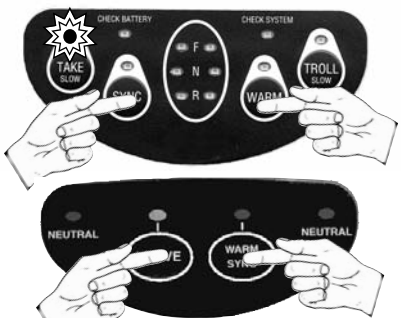

To Enter Handle Troubleshoot Mode, follow these steps:

1	ACTION	RESULT
	<p>Turn power to control system OFF</p>	<p>Check to see that the control head keypad LEDs are NOT illuminated. This is a visual indication that the system has been turned OFF.</p>
	<p>Move handles to their FULL AHEAD positions</p>	<p>N/A</p>
	<p>Turn power to control system ON</p>	<p>When the system has been turned on the TAKE LED or ACTIVE LED will blink slowly and a beeping sound will emit from the control head keypad.</p>
	<p>PRESS & RELEASE the two center buttons on the keypad simultaneously 3 times</p>	<p>After pressing the two buttons, the keypad's 4 LEDs will now begin to alternate between slow flashing and fast flashing every 4 seconds.</p>

6.1 Retrieve alarm count & alarm codes

The control head keypad LEDs will alternate between **slow blinking** and **fast blinking**, every 4 seconds, to indicate the alarm count and the alarm codes. The system stores in memory the 16 most recent alarm codes beginning with the latest.

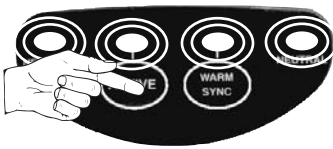

To Retrieve Alarm Count & Alarm Codes, follow these steps:

		ACTION	RESULT
1 4-BUTTON KEYPAD 	2-BUTTON OR ITC KEYPAD 	Record the sequence of flashing LEDs in the space provided on the chart on page 36	Using the chart on page 36, determine the number of alarm counts.
		2 4-BUTTON KEYPAD 	2-BUTTON OR ITC KEYPAD 

6.2 Deleting Alarm Codes and Resetting Alarm Count to Zero

While in Handle Troubleshoot Mode you can delete the 16 most recent alarm codes and reset the alarm count to zero at any time after viewing one or more alarm codes. Deleting alarm codes and resetting alarm count will minimize confusion for future troubleshooting. Follow the step below:

To Delete Alarm Codes & Reset Alarm Count to Zero, follow this step:

		ACTION	RESULT
1 4-BUTTON KEYPAD 	2-BUTTON OR ITC KEYPAD 	4-button keypads: PRESS & RELEASE the SYNC & WARM buttons 2-button keypads: PRESS & RELEASE the ACTIVE & WARM buttons	All LEDs will flash to indicate that alarm codes and alarm count have been reset. You may perform this procedure at any time after retrieving alarm information.

6.3 Exiting Handle Troubleshoot Mode

Once alarm codes have been reviewed and / or deleted, simply turn the system OFF and return the main station control handles to NEUTRAL before restarting system.

To Exit Handle Troubleshoot Mode, follow this step:

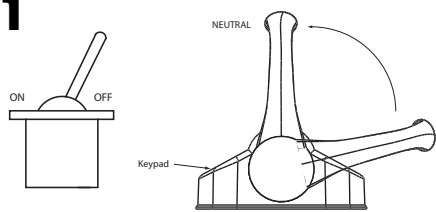
1 	ACTION	RESULT
	Turn Power OFF and return control head handles to their NEUTRAL positions	You may now restart the system for normal operation.

EXAMPLE

The following describes an actual problem that occurred on a boat which will illustrate the use of our troubleshooting mode.

For the purpose of this example we will demonstrate using the **4-button keypad**.

When John turned his system on he noticed that all 4 LEDs on the keypad were flashing and the control head was beeping. He knew this was not normal and wanted to troubleshoot what was wrong.

All LEDs flashing

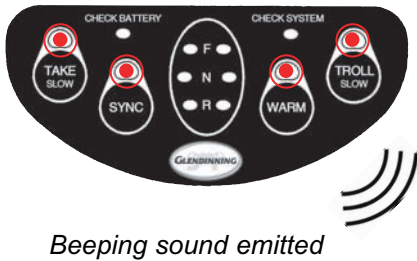

John entered the system into "Handle Troubleshoot Mode" by **turning the system OFF**, moving the handles of the main station control **into the FULL AHEAD position**, and **turning the system back ON**. He then pressed the 2 center buttons on the keypad simultaneously 3 times. Now John can easily troubleshoot the problem.

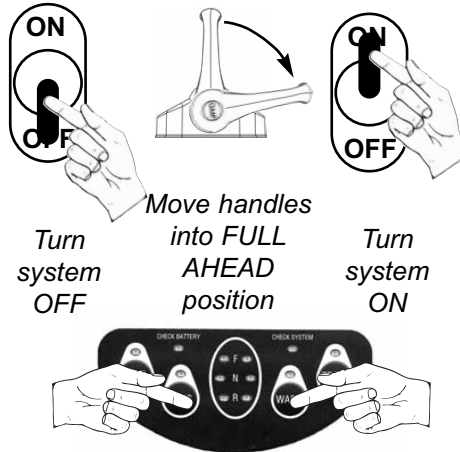

John next noticed that the keypad LEDs began to alternate every 4 seconds between **slow blinking** and **fast blinking**. He recorded the LEDs that were blinking slow and the LEDs that were blinking fast on the chart (see pg. 36). The sequence below showed the system went into alarm a total of 3 times.

Slow blinking



Fast blinking



John **pressed the SYNC button** to reveal the first alarm code. He recorded the sequence of blinking LEDs (pg. 37) and using the alarm code description chart (pg. 38), John determined that the battery voltage at startup was below 9.6 volts. By pressing the SYNC button a second time John was able to retrieve the next alarm code, and repeated this process for the last alarm code.

Slow blinking



Fast blinking



Now that John discovered that the reason for the Smart Actuator II™ system alarm code was low battery input voltage, he was able to focus on discovering the reason for this low battery voltage.

After further investigation, he found two problems with his battery supply to the control system. The first problem is that only one battery power source was connected to the Smart Actuator II™ system, rather than two battery sources (see section 3.1 for more information).



Secondly, the battery source that was connected (generator battery) was very low in voltage due to a failed battery charger. John fixed the problem with the generator battery charger, which charged the generator battery, and the Smart Actuator II™ system immediately began to operate. Later, John had his marine electrician install a wire and circuit breaker to his house (domestic) battery source to provide a second battery source for the Smart Actuator II™ system.



Alarm Codes Description chart

Check alarm code values that you recorded on the preceding page with the list of alarm code descriptions below. Enter the description in the appropriate column on the chart.

LEDs SLOW BLINKING				LEDs FAST BLINKING				ALARM CODE DESCRIPTION
TAKE PORT N	SYNC ACTIVE	WARM WARM	TROLL STBD N	TAKE PORT N	SYNC ACTIVE	WARM WARM	TROLL STBD N	
								Detected multiple handles with the same handle ID at startup.
								No handle connected at startup.
								Handle #1 PORT potentiometer reading below 0.25V or above 4.75V.
								Handle #2 PORT potentiometer reading below 0.25V or above 4.75V.
								Handle #3 PORT potentiometer reading below 0.25V or above 4.75V.
								Handle #4 PORT potentiometer reading below 0.25V or above 4.75V.
								Handle #5 PORT potentiometer reading below 0.25V or above 4.75V.
								Handle #6 PORT potentiometer reading below 0.25V or above 4.75V.
								Handle #1 STBD potentiometer reading below 0.25V or above 4.75V.
								Handle #2 STBD potentiometer reading below 0.25V or above 4.75V.
								Handle #3 STBD potentiometer reading below 0.25V or above 4.75V.
								Handle #4 STBD potentiometer reading below 0.25V or above 4.75V.
								Handle #5 STBD potentiometer reading below 0.25V or above 4.75V.
								Handle #6 STBD potentiometer reading below 0.25V or above 4.75V.
								**CP lost communication with Handle #1.
								**CP lost communication with Handle #2.
								**CP lost communication with Handle #3.
								**CP lost communication with Handle #4.
								**CP lost communication with Handle #5.
								**CP lost communication with Handle #6 (will not be stored).
** = Handle loosing communication will cause an alarm condition if handle is the active handle at time of fault								
								Detected multiple actuators with the same actuator ID at startup.
								CP actuator configuration does not match actuator settings.
								CP lost communication with actuator #1 (port throttle / gear).
								CP lost communication with actuator #2 (stbd throttle / gear).
								CP lost communication with actuator #3 (port / stbd troll).
								CP lost communication with actuator #4 (port / stbd throttle / electronic gear).
								CP lost communication with actuator #6 (center throttle / gear).

LEDs SLOW BLINKING				LEDs FAST BLINKING				ALARM CODE DESCRIPTION
TAKE PORT N	SYNC ACTIVE	WARM WARM	TROLL STBD N	TAKE PORT N	SYNC ACTIVE	WARM WARM	TROLL STBD N	
								Actuator # 1 battery input below 11.5V / 23V (code not stored in history).
								Actuator # 1 battery input above 16V / 30V (code not stored in history).
								Actuator # 1 battery input below 10V / 19V.
								Actuator # 1 battery input above 17V / 32V.
								Actuator # 1 battery reading does not match 12 or 24V input range.
								Actuator # 1 — PORT throttle exceeded 5A for more than 6 seconds.
								Actuator # 1 — PORT throttle can't reach commanded position.
								Actuator # 1 — PORT throttle feedback more than 4.80V or less than 0.20V.
								Actuator # 1 — PORT gear exceeded 5A for more than 6 seconds.
								Actuator # 1 — PORT gear can't reach commanded position.
								Actuator # 1 — PORT gear feedback more than 4.80V or less than 0.20V.
								Actuator # 1 — PORT actuator solenoid not locked down.
								Actuator #2 — battery input below 11.5V / 23V (code not stored in history).
								Actuator #2 — battery input above 16V / 30V (code not stored in history).
								Actuator #2 — battery input below 10V / 19V.
								Actuator #2 — battery input above 17V / 32V.
								Actuator # 2 battery reading does not match 12 or 24V input range.
								Actuator # 2 — STBD throttle exceeded 5A for more than 6 seconds.
								Actuator # 2 — STBD throttle can't reach commanded position.
								Actuator # 2 — STBD throttle feedback more than 4.80V or less than 0.20V.
								Actuator # 2 — STBD gear exceeded 5A for more than 6 seconds.
								Actuator # 2 — STBD gear can't reach commanded position.
								Actuator # 2 — STBD gear feedback more than 4.80V or less than 0.20V.
								Actuator # 2 — STBD actuator solenoid not locked down.
								Actuator #3 — battery input below 11.5V / 23V (code not stored in history).
								Actuator #3 — battery input above 16V / 30V (code not stored in history).
								Actuator #3 — battery input below 10V / 19V.
								Actuator #3 — battery input above 17V / 32V.
								Actuator #3 battery reading does not match 12 or 24V input range.
								Actuator #3 — PORT troll exceeded 5A for more than 6 seconds.
								Actuator #3 — PORT troll can't reach commanded position.
								Actuator #3 — PORT troll feedback more than 4.80V or less than 0.20V.
								Actuator #3 — STBD troll exceeded 5A for more than 6 seconds.
								Actuator #3 — STBD troll can't reach commanded position.
								Actuator #3 — STBD troll feedback more than 4.80V or less than 0.20V.

LEDs SLOW BLINKING				LEDs FAST BLINKING				ALARM CODE DESCRIPTION
TAKE PORT N	SYNC ACTIVE	WARM WARM	TROLL STBD N	TAKE PORT N	SYNC ACTIVE	WARM WARM	TROLL STBD N	
								Actuator #4 — battery input below 11.5V / 23V (code not stored in history).
								Actuator #4 — battery input above 16V / 30V (code not stored in history).
								Actuator #4 — battery input below 10V / 19V.
								Actuator #4 — battery input above 17V / 32V.
								Actuator # 4 — battery reading does not match 12 or 24V input range.
								Actuator #4 — PORT throttle exceeded 5A for more than 6 seconds.
								Actuator #4 — PORT throttle can't reach commanded position.
								Actuator #4 — PORT throttle feedback more than 4.80V or less than 0.20V.
								Actuator #4 — STBD throttle exceeded 5A for more than 6 seconds.
								Actuator #4 — STBD throttle can't reach commanded position.
								Actuator #4 — STBD throttle feedback more than 4.80V or less than 0.20V.
								Actuator #5 — battery input below 11.5V / 23V (code not stored in history).
								Actuator #5 — battery input above 16V / 30V (code not stored in history).
								Actuator #5 — battery input below 10V / 19V.
								Actuator #5 — battery input above 17V / 32V.
								Actuator #5 — battery reading does not match 12 or 24V input range.
								Actuator #5 — PORT throttle exceeded 5A for more than 6 seconds.
								Actuator #5 — PORT throttle can't reach commanded position.
								Actuator #5 — PORT throttle feedback more than 4.80V or less than 0.20V.
								Actuator #5 — STBD throttle exceeded 5A for more than 6 seconds.
								Actuator #5 — STBD throttle can't reach commanded position.
								Actuator #5 — STBD throttle feedback more than 4.80V or less than 0.20V.
								Actuator #6 — battery input below 11.5V / 23V (code not stored in history).
								Actuator #6 — battery input above 16V / 30V (code not stored in history).
								Actuator #6 — battery input below 10V / 19V.
								Actuator #6 — battery input above 17V / 32V.
								Actuator # 6 — battery reading does not match 12 or 24V input range.
								Actuator #6 — CENTER throttle exceeded 5A for more than 6 seconds.
								Actuator #6 — CENTER throttle can't reach commanded position.
								Actuator #6 — CENTER throttle feedback more than 4.80V or less than 0.20V.
								Actuator #6 — CENTER gear exceeded 5A for more than 6 seconds.
								Actuator #6 — CENTER gear can't reach commanded position.
								Actuator #6 — CENTER gear feedback more than 4.80V or less than 0.20V.

7.0 Appendix / Reference

The Appendix / Reference section is divided as follows:

7.1 Wiring Diagrams (many other engine layouts available, contact GMP)

A. SINGLE Engine Wiring Diagram	.43
B. TWIN Engine Wiring Diagram	.44
C. TWIN Engine w/TROLL Wiring Diagram	.45
D. TWIN Engine w/ELECTRIC GEAR Wiring Diagram	.46
E. Smart Actuator II™ Harnesses	.47

7.2 Dimensional Drawings / Cutout Templates

A. Actuator Dimensions	.51
B. Actuator Mounting Dimensions	.52
C. Actuator Parts	.53
D. 2-button Control Head CP Dimensions	.54
E. 2-button Control Head (Remote) Dimensions	.55
F. 4-button Control Head CP Dimensions	.56
G. 4-button Control Head (Remote) Dimensions	.57
H. Cutout templates for Control Heads	.59

7.3 Sidemount Controls Installation (optional)

A. Sidemount Handle Control Assembly	.63
B. Sidemount Keypad Assembly	.65
C. Sidemount Handle Control Dimensions	.66
D. Sidemount Keypad Assembly Dimensions	.67
E. Cutout template for Sidemount Keypad Assembly	.69

7.4 Control Head Configuration (optional)

A. Configuring Control Head Identifier	.71
--	-----

7.5 Control Processor Functional Configuration (optional)

7.5.1 Actuator Options	.74
7.5.2 Throttle on Top of Troll Options	.75
7.5.3 Troll Delay Options	.76
7.5.4 Throttle Delay Options	.77
7.5.5 Gear Delay Options	.78

7.5.6 Hi-Idle Step Size (part 1)79

7.5.7 Hi-Idle Step Size (part 2)80

7.5.8 System Startup Options81

7.5.9 Station Transfer Options82

7.5.10 Return Settings to Default Option83

7.5.11 Sync Gain Options84

7.5.12 Mechanical Backup Options85

7.5.13 Neutral Delay Options86

7.5.14 Throttle Curve Select Option87

7.5.15 Throttle Bump Amount Option89

7.5.16 Selectable Sync Master Option90

7.6 Actuator Functional Configuration (optional)

7.6.1 Setting the Actuator Default Option91

7.6.2 Setting the Actuator Identifier92

7.6.3 Setting the Tachometer Pulses / Revolution (PPR)93

7.6.4 Setting the Cable Travel Direction ONLY94

7.7 Triple Engine Applications (optional)

Description97

Operation97

TRIPLE Engine Wiring Diagram98

TRIPLE Engine Harnesses99

SINGLE Engine Wiring Diagram

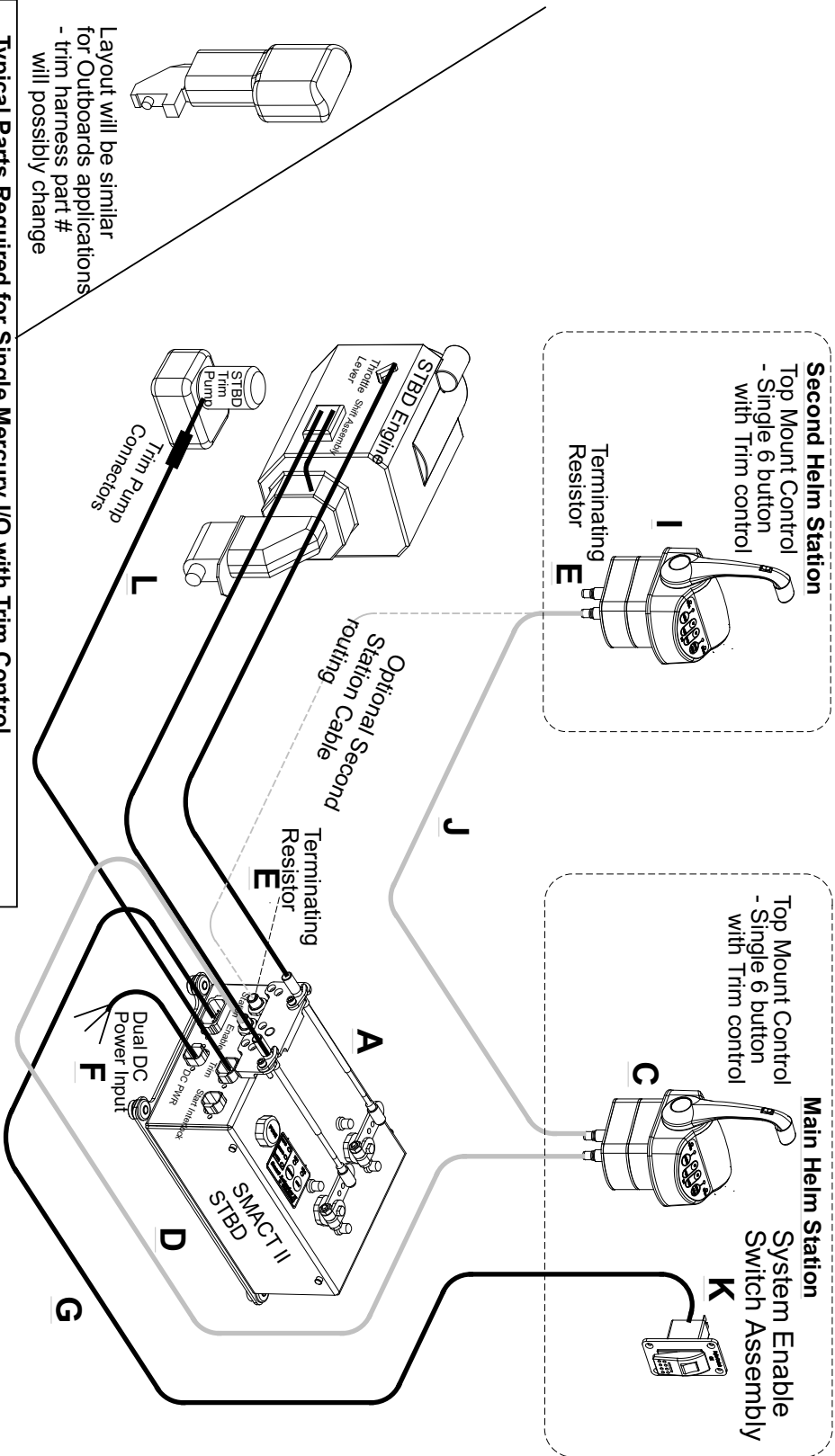

Layout will be similar for Outboards applications - trim harness part # will possibly change

Typical Parts Required for Single Mercury I/O with Trim Control

Item	Qty	Part #	Description
A	(1)	11314-xx-TMG-S	Smart Actuator II STBD (12 or 24V DC)
C	(1)	11416-C-CP-SGL	CH2001 Control Head CP with Trim Single
D	(1)	11600-02-xx	Station Cable (20 - 100' long)
E	(2)	11600-TRF	Terminating Resistors
F	(1)	11601-01	Harness - DC Power Input (30' long std.)
G	(1)	11603-02-S-xx	Harness - Enable STBD (20-100'long)
L	(1)	11611-xx-xx	Harness - Trim Control - Mercury Pump
I	(1)	11416-C-CP-SGL	CH2001 Control Head CP with Trim Single
J	(1)	11600-02-xx	Station Cable (20-100' long)
K	(1)	11490-x	Enable Switch Assembly (Black or White nameplate)

NOTE : Control cables can be supplied by Glendinning - SMACT II will accept SAE 33C or Merc GEN II cables

TWIN Engine Wiring Diagram

Typical Parts Required for Twin Mercury I/O with Trim Control

Item	Qty	Part #	Description
A	(1)	11314-xx-TMG-S	Smart Actuator II - STBD (12 or 24v DC)
B	(1)	11314-xx-TMG-P	Smart Actuator II PORT (12 or 24v DC)
C	(1)	11416-C-CP	CH2001 Control Head CP with Trim Control
D	(2)	11600-02-xx	Station Cables (20 - 100' long)
E	(2)	11600-TRF	Terminating Resistors
F	(2)	11601-01	Harness - DC Power Input (30' long std.)
G	(1)	11603-02-S-xx	Harness - Enable STBD (20-100'long)
H	(1)	11603-02-P	Harness - Enable/Tach PORT (30' long std.)
I	(2)	11611-xx-xx	Harness - Trim Control - Mercury Pump
L	(2)	11611-xx-xx	Harness - Trim Control - Mercury Pump
Extra Control Station requires			
	(1)	11416-C-CP	CH2001 Control Head CP with Trim Control
	(1)	11600-02-xx	Station Cable (20-100' long)
Optional Enable Switch Assembly			
K	(1)	11490-x	Enable Switch Assembly (Black or White nameplate)

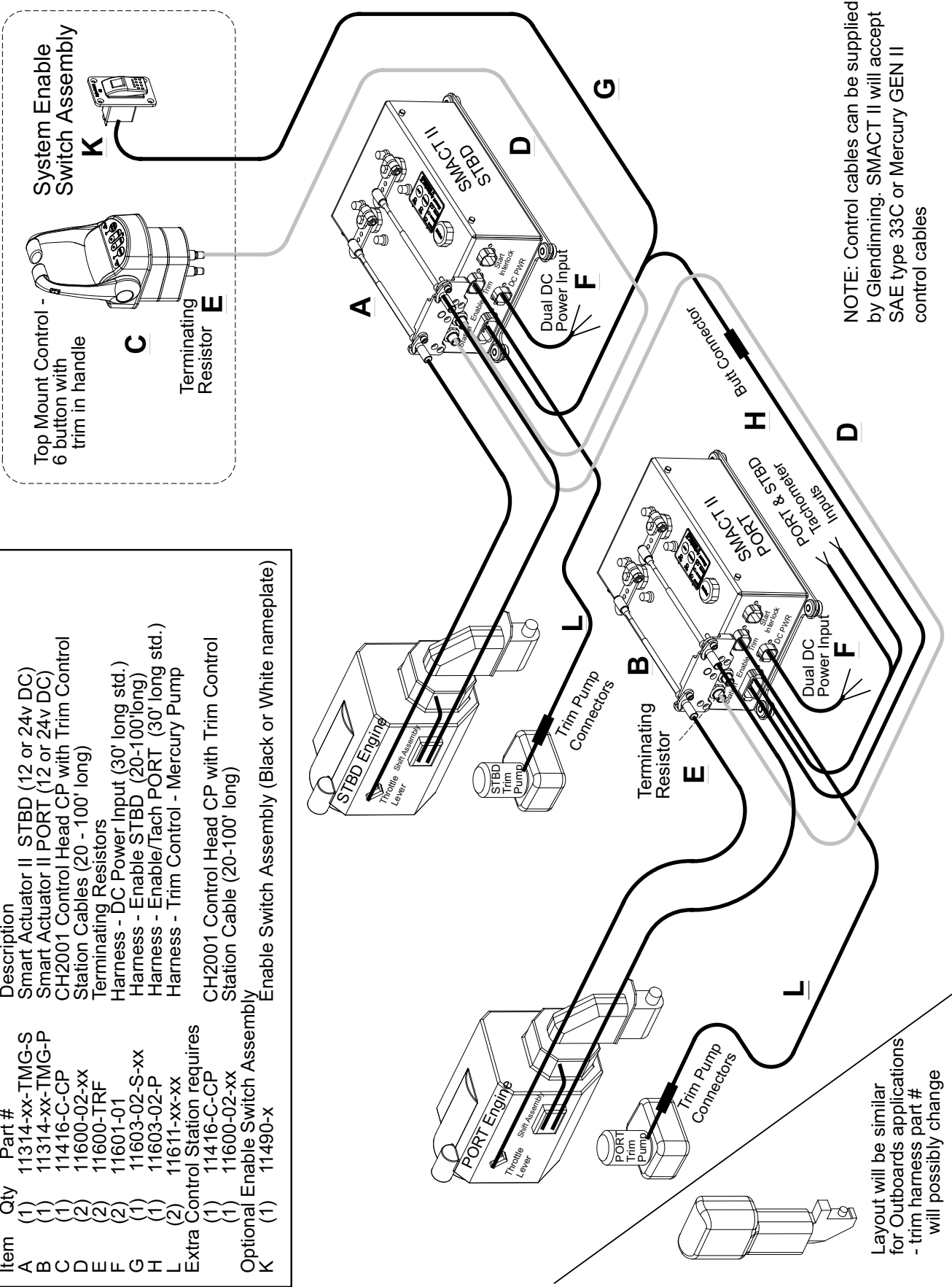

NOTE: Control cables can be supplied by Glendinning. SMACT II will accept SAE type 33C or Mercury GEN II control cables

Layout will be similar for Outboards applications - trim harness part # will possibly change

TWIN Engine w/TROLL Wiring Diagram

- Twin Engine
- Mechanical Throttle
- Mechanical Gear
- Mechanical Trolling Valve
- Twin Helm Stations

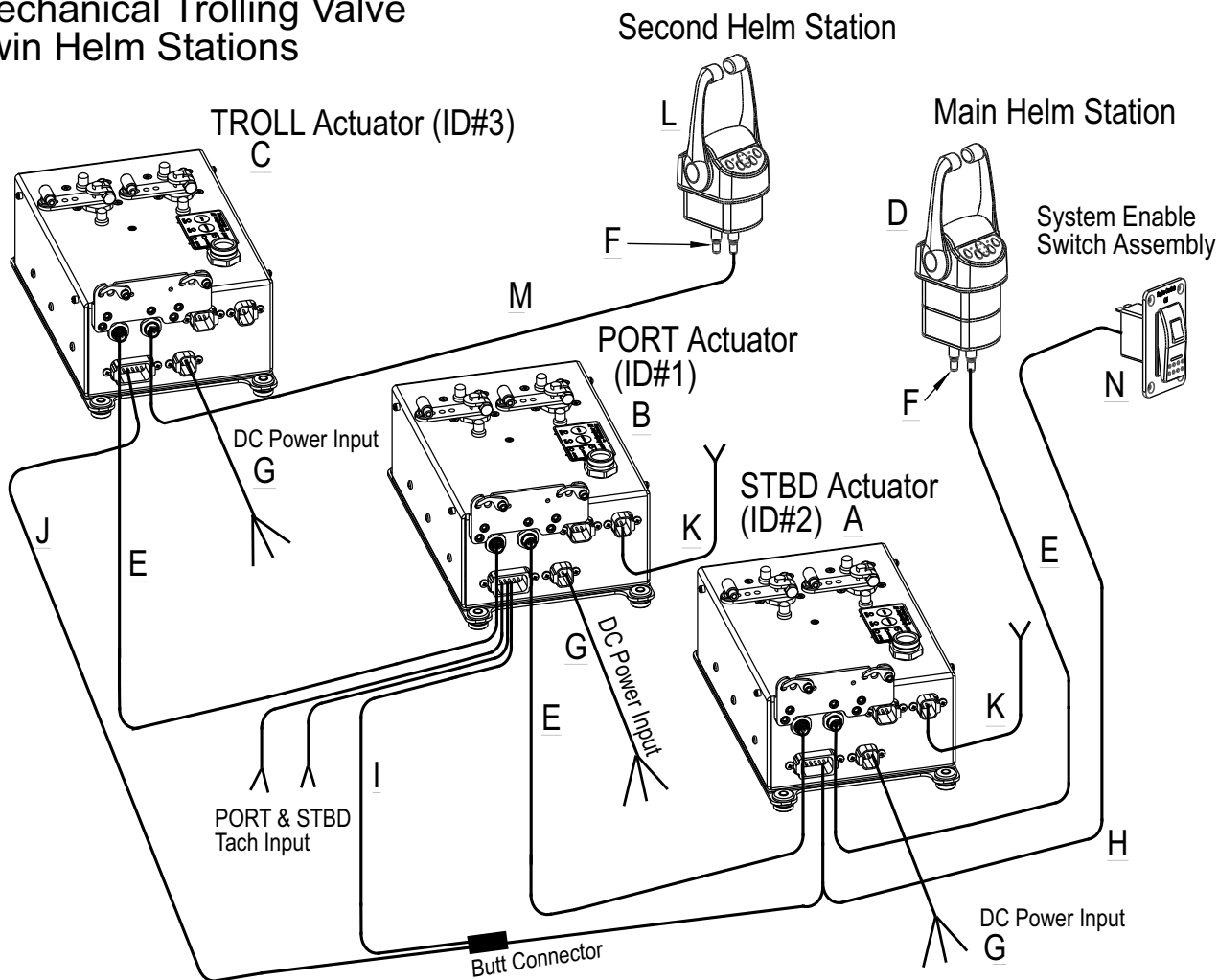

Typical Parts Required

Item	Qty	Part #	Description
A	(1)	11314-xx-TMG-S	Smart Actuator II STBD (12 or 24v DC)
B	(1)	11314-xx-TMG-P	Smart Actuator II PORT (12 or 24v DC)
C	(1)	11314-xx-TROLL	Smart Actuator II TROLL (12 or 24v DC)
D	(1)	11413-CT-CP	CH2001 Control Head 4 button CP
E	(3)	11600-02-XX	Station Cable (20 - 100' lengths)
F	(2)	11600-TRF	Terminating Resistors
G	(3)	1 1601-01	Harness - DC Power Input (30' length std.)
H	(1)	11603-02-S-xx	Harness - Enable STBD (20 - 100' lengths)
I	(1)	11603-02-P	Harness - Enable/Tach PORT (30' length std)
J	(1)	11603-02-TROLL	Harness - Enable TROLL (30' length)
K	(2)	11602-02	Harness - Start Interlock (20' length)
Extra Control Station Requires			
L	(1)	11413-C15T	CH2001 Control Head 4 button
M	(1)	11600-02-xx	Station Cable (20 - 100' lengths)
Optional Enable Switch Assembly			
N	(1)	11490-x	Enable Switch Assembly (Black or White nameplate)

TWIN Engine w/ELECTRIC Gear Wiring Diagram

- Twin Engine
- Mechanical Throttle
- Electric Gear
- Twin helm station
- 4-button Control Head
(2-button available)

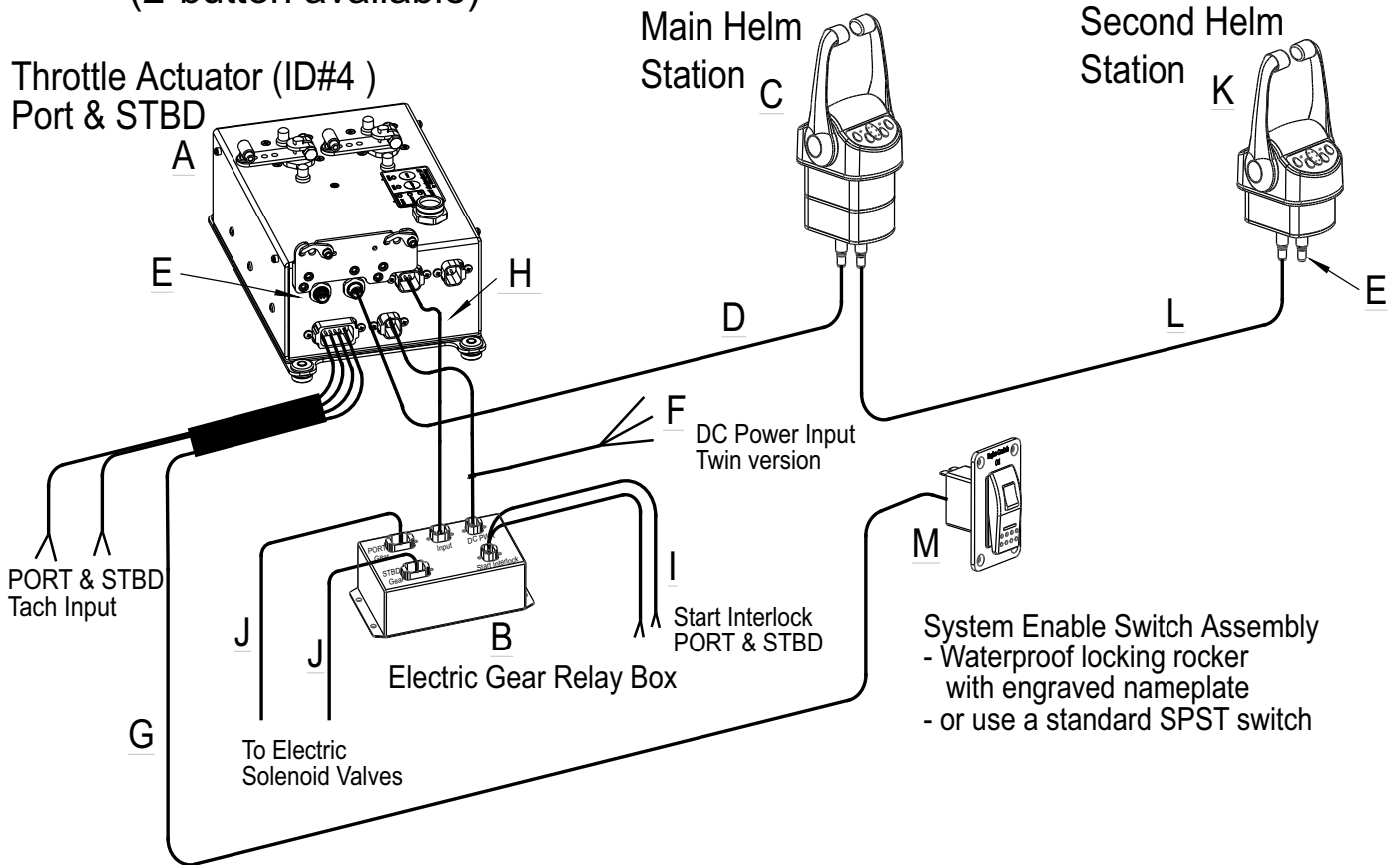

Typical Parts Required			
Item	Qty	Part #	Description
A	(1)	11314-xx-TEG	Smart Actuator II Throttle/Electric Gear (12 or 24v DC)
B	(1)	11705-xx	Electric Gear Relay Output Box (12 or 24v DC)
C	(1)	11413-CT-CP-TEG	CH2001 Control Head 4 button CP
D	(1)	11600-02-xx	Station Cable (20 - 100' lengths)
E	(2)	11600-TRF	Terminating Resistors
F	(1)	11601-02	Harness - DC Power Input Twin (30' length std.)
G	(1)	11603-02-TEG-xx	Harness - Enable TEG (20 - 100' lengths)
H	(1)	11609-03-xx	Harness - Interconnect (12 or 24v DC)
I	(1)	11602-01	Harness - Start Interlock (30' length std.)
J	(2)	11604-L1-xx	Harness - Gear ZF IRM (10 - 30' lengths)
(Note: harnesses available for other transmissions)			
Extra Control Station Requires			
K	(1)	11413-C15T	CH2001 Control Head 4 button
L	(1)	11600-02-xx	Station Cable (20 - 100' lengths)
Optional Enable Switch Assembly			
M	(1)	11490-x	Enable Switch Assembly (Black or White nameplate)

Complete Control - Smart Actuator Harnesses

Station Cable
Part # 11600-02-xx' (available 20' - 100' in 20' increments)

NOTE: Connector Nut must turn 6 turns to ensure a complete connection

Connector is the same on both ends

Terminating Resistor
Part # 11600-TRF

Two required per system

DC Power Harness
Part # 11601-01 (30' long std.)

NOTE: Power wires are 30' long standard (custom lengths available)

Control Process End Duetsch 4 pos. Black (Noise Supression devices)

Battery Positive #1 (Red wire)
Battery Positive #2 (Red wire)
Battery Negative (yellow wire)

DC Power Harness - Twin Output Part # 11601-02 (30' long std.)

2 ft. 30 ft.

Note: Rear of connector shown

Smart Actuator - Single Engine Harness
Part # 11603-02-SGL-xx

SINGLE Enable Switch End - see GMP Enable Switch Kit #11490-x - or a SPST installer provided switch

(10' - 100' lengths avail. in 10' increments)
xx' in part number represents length of harness

White
Black

NOTE: DO NOT provide power to this end, only close the circuit using a N.O. switch

Control Process End Duetsch 12 pos. Grey

Connector Detail Note: Rear of connector shown

To Enable switch at helm

Complete Control - Smart Actuator Harnesses

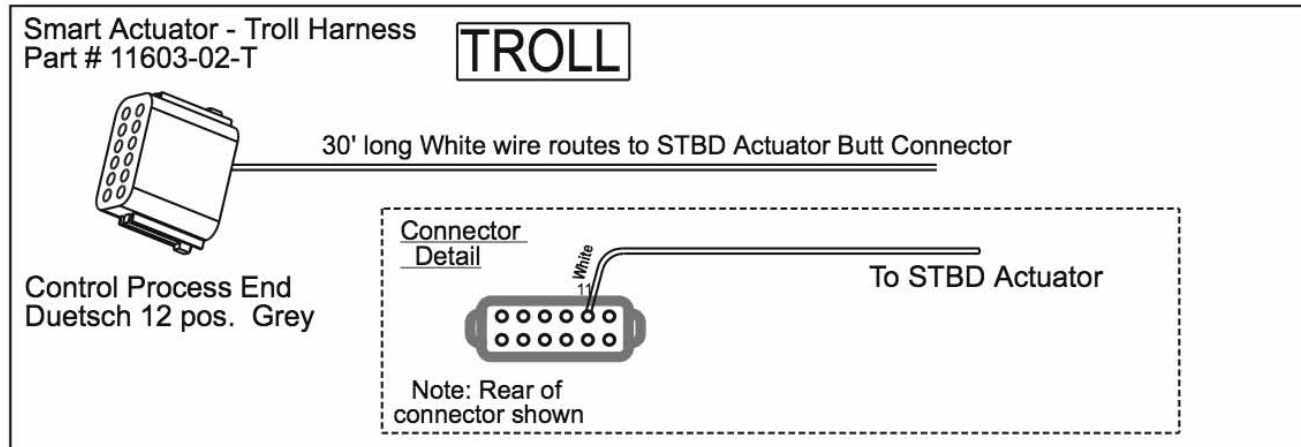
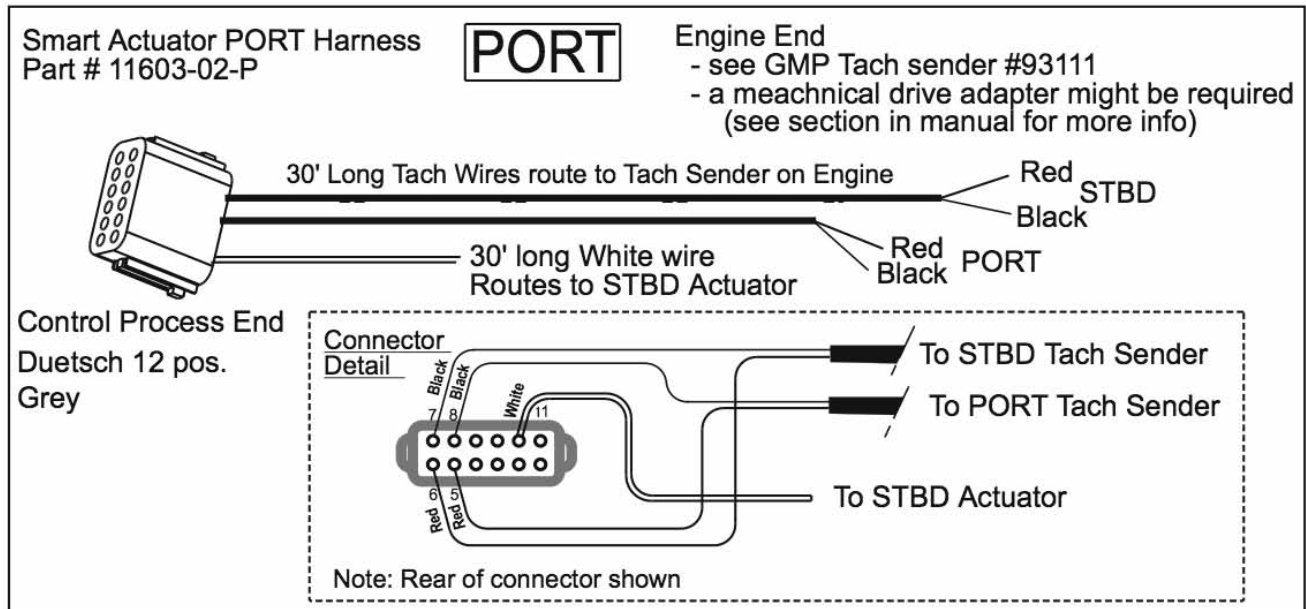
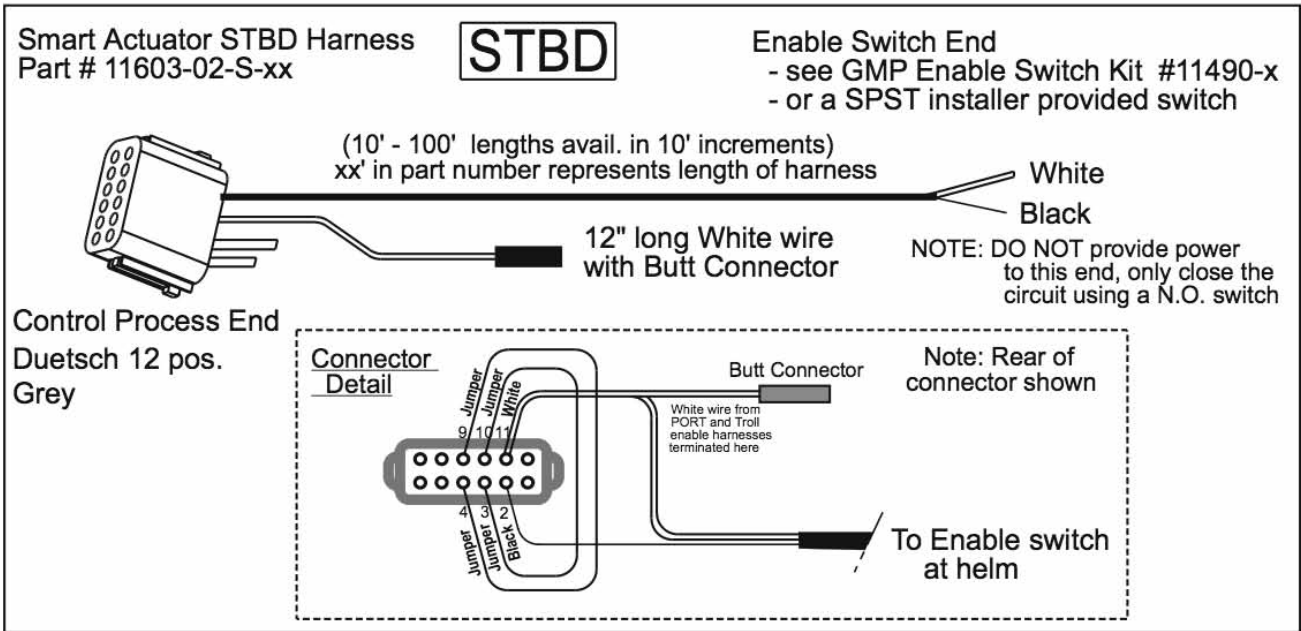

Complete Control - Smart Actuator Harnesses

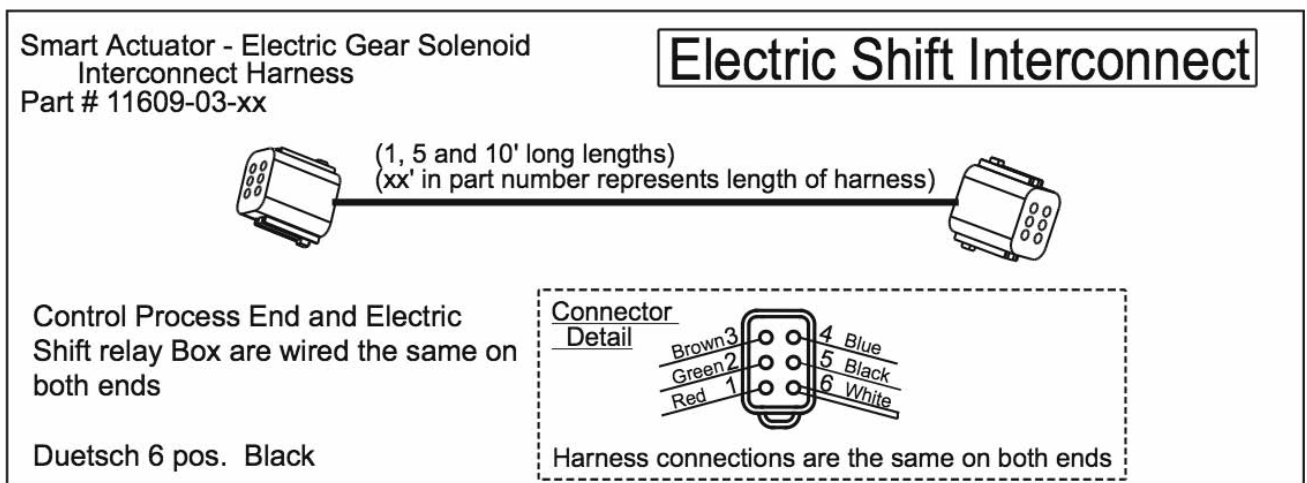
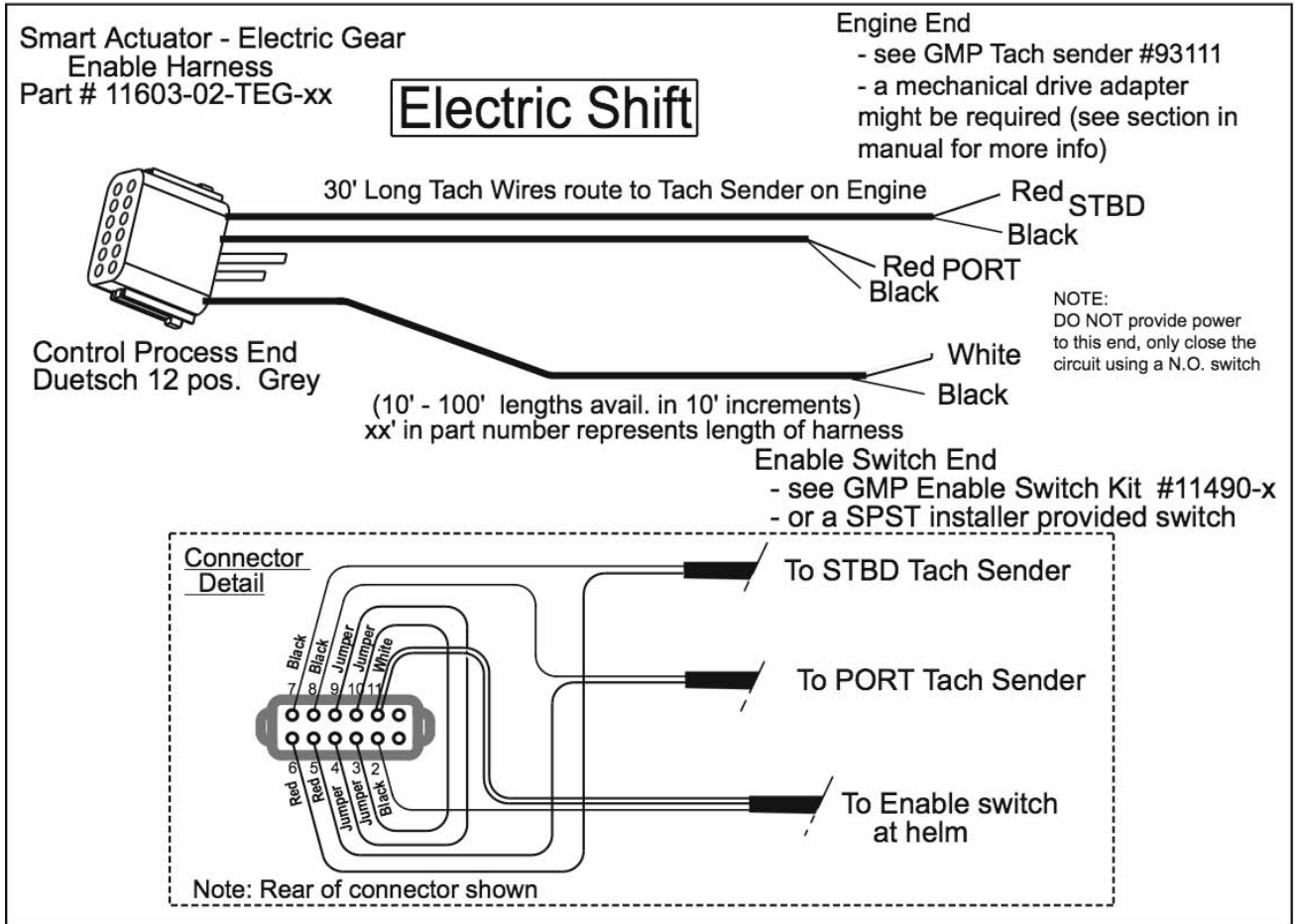

Complete Control - Smart Actuator Harnesses

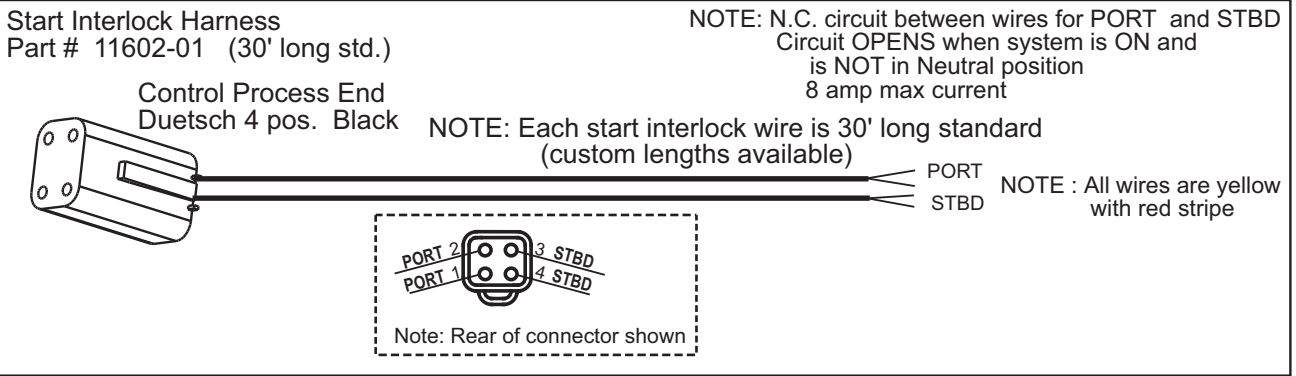
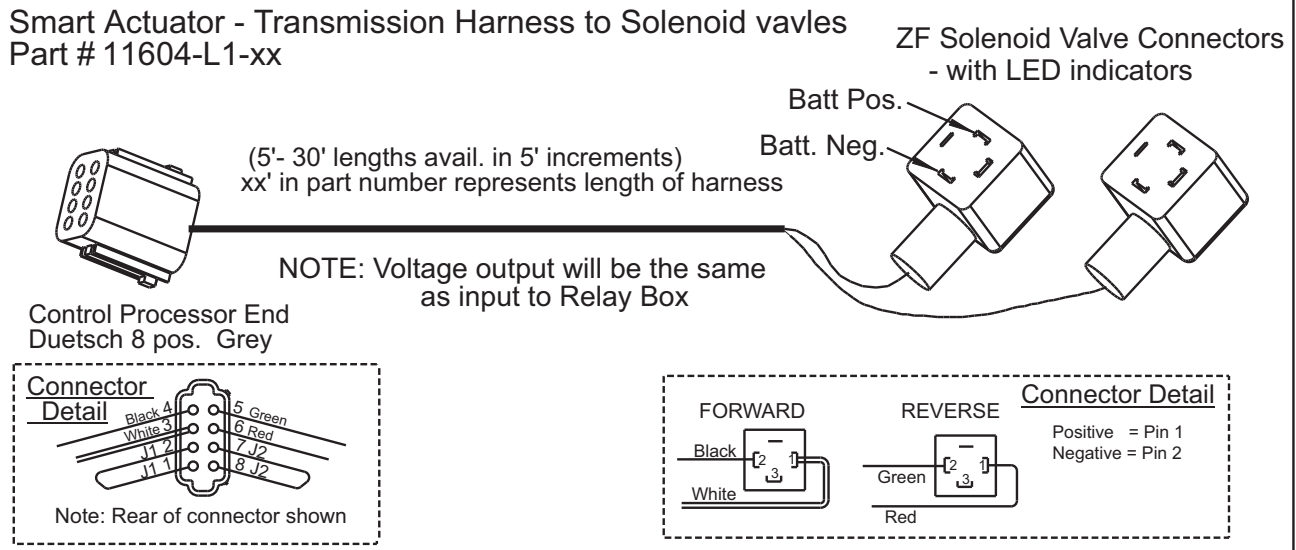

Actuator Dimensions

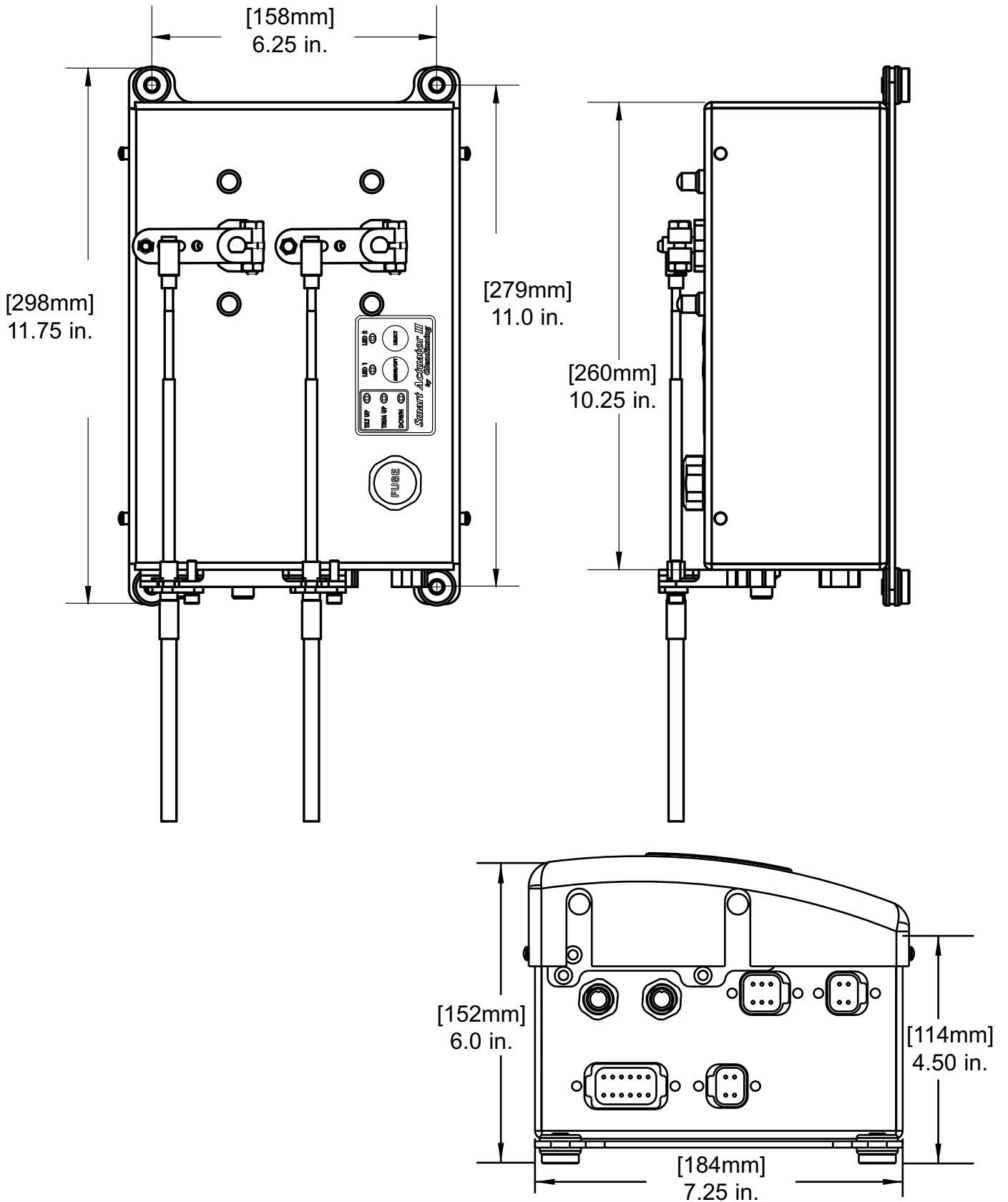

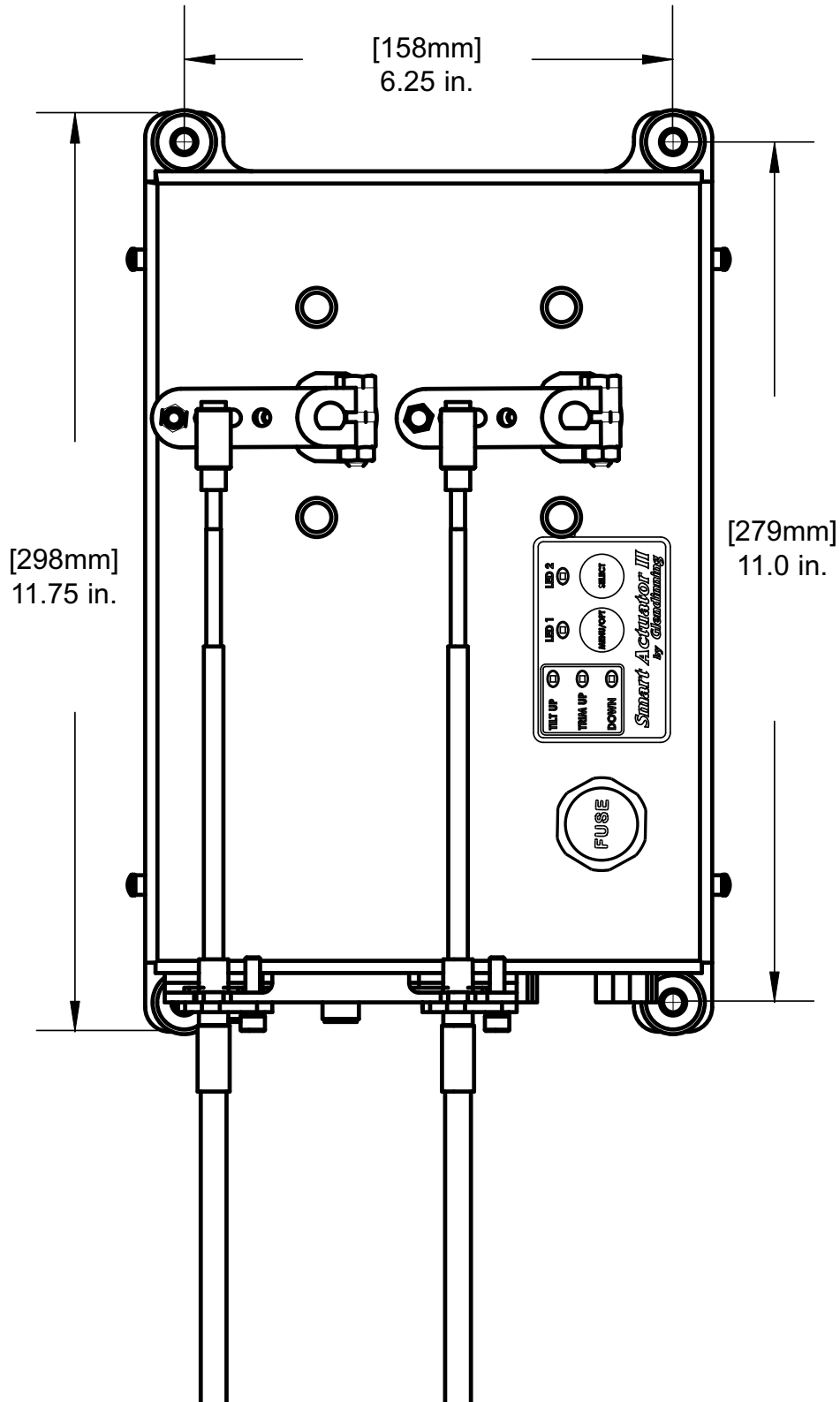
Smart Actuator II™ Mounting Dimensions

Actuator Parts

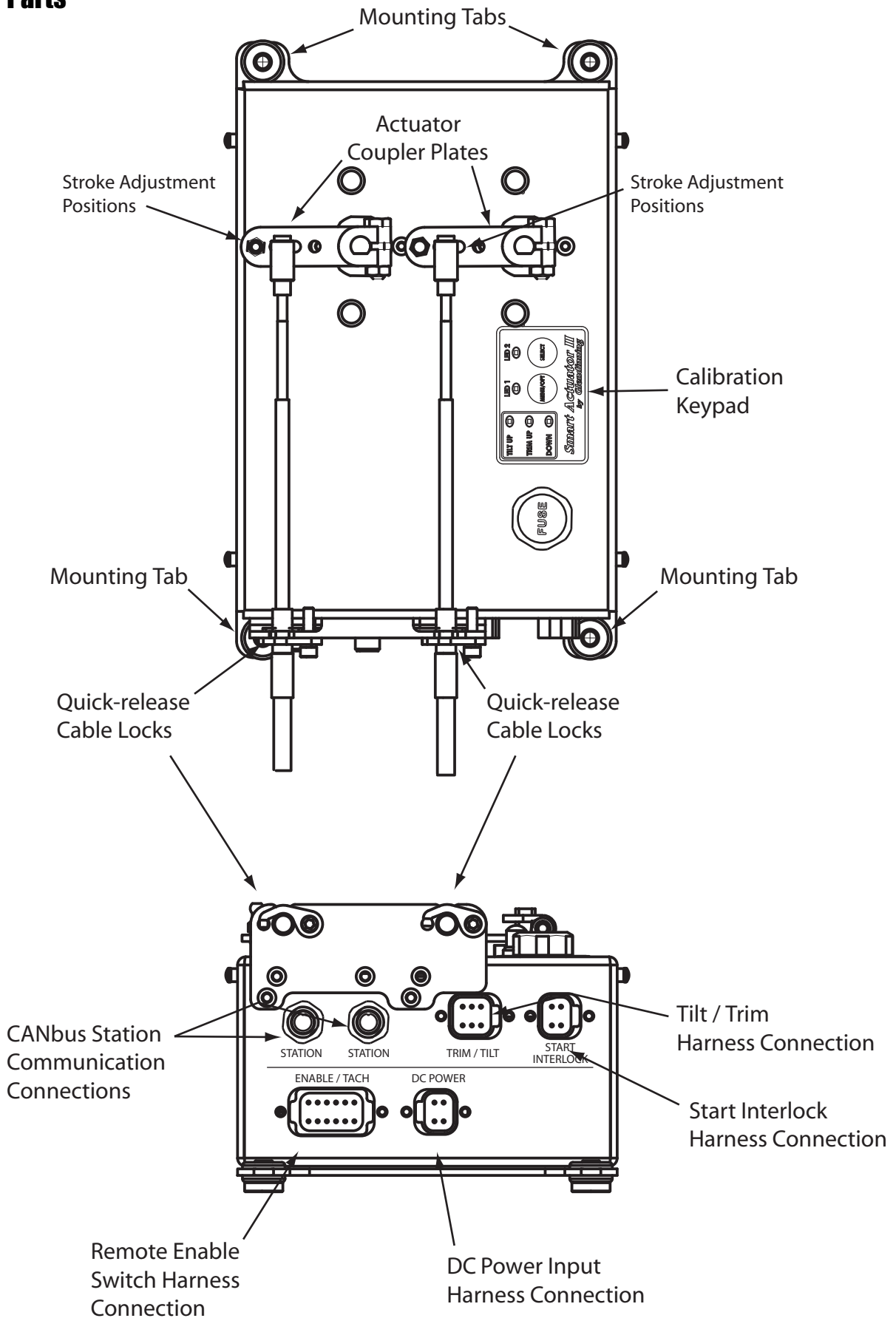

2-button Control Head CP Dimensions

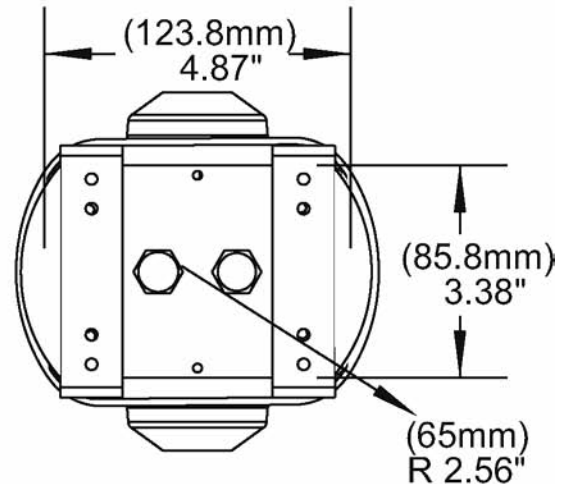
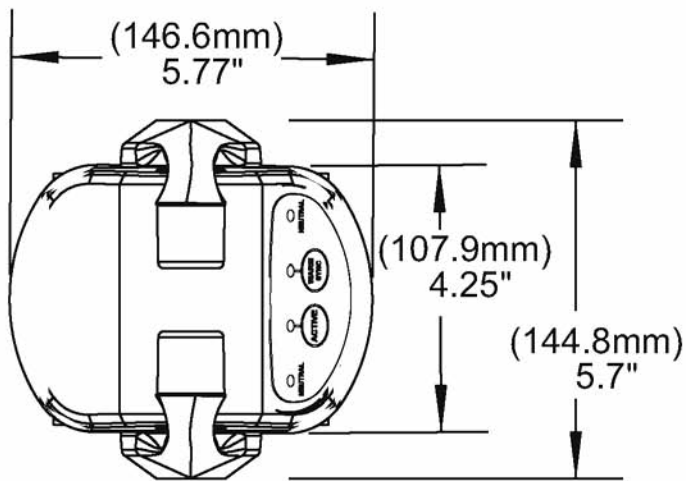
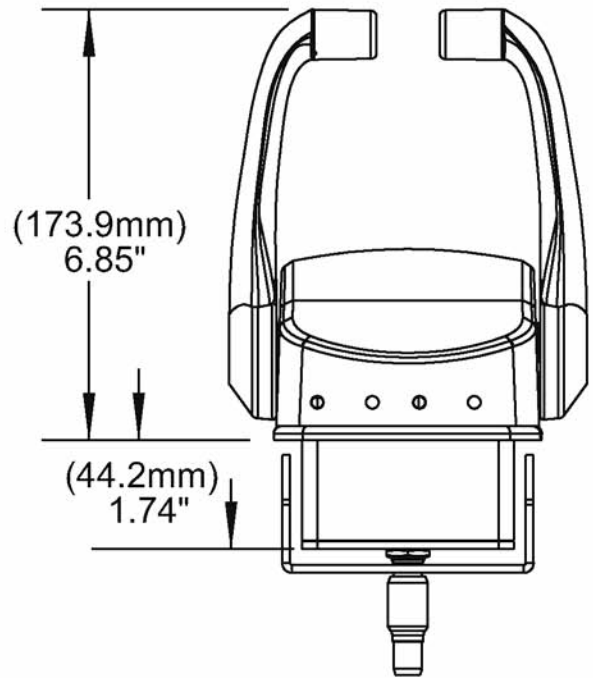
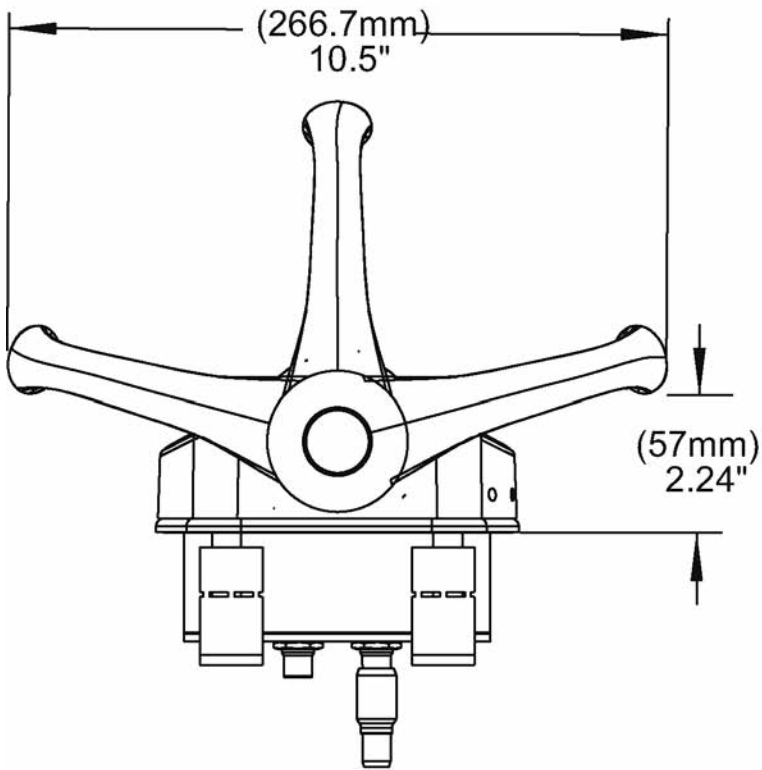

2-button Control Head (Remote) Dimensions

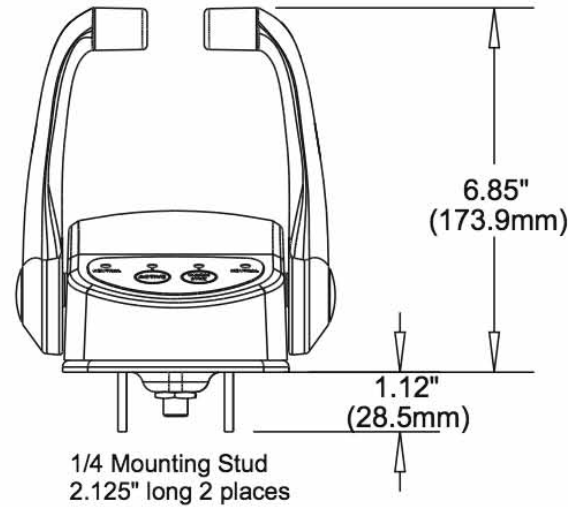
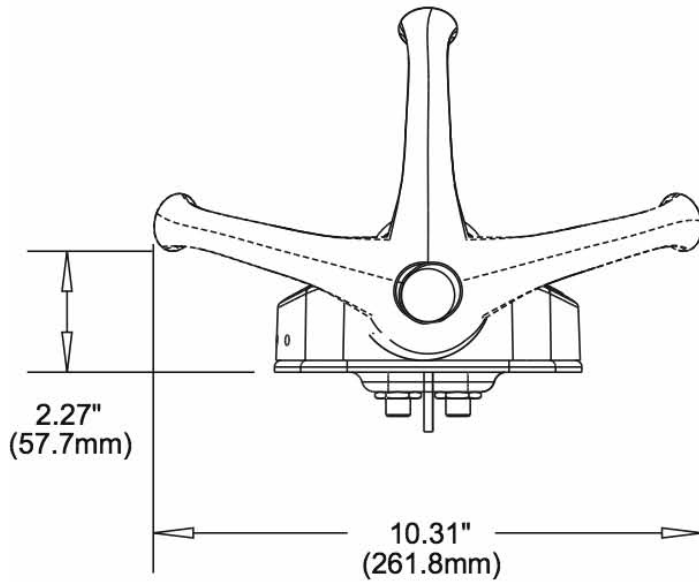
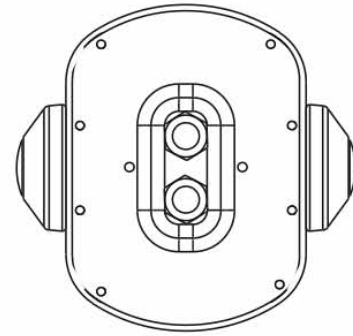
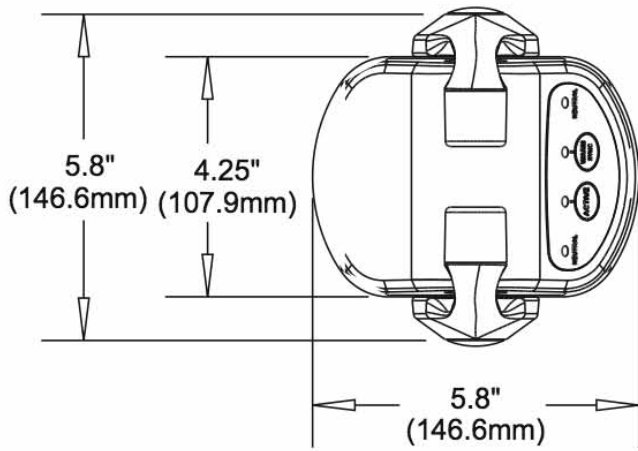
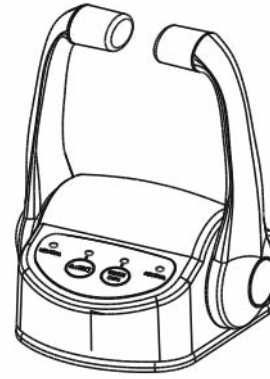

NOTE: 2.0" [51mm] required below connector for cable connector

4-button Control Head CP Single Dimensions

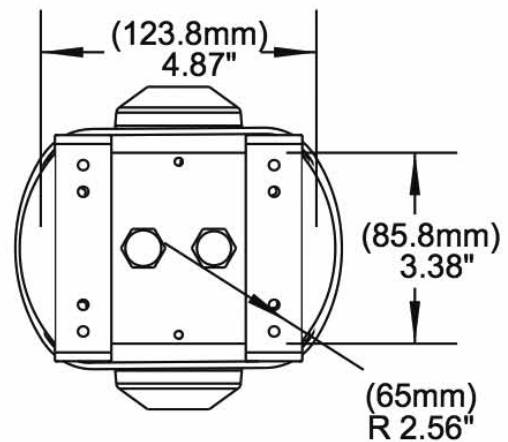
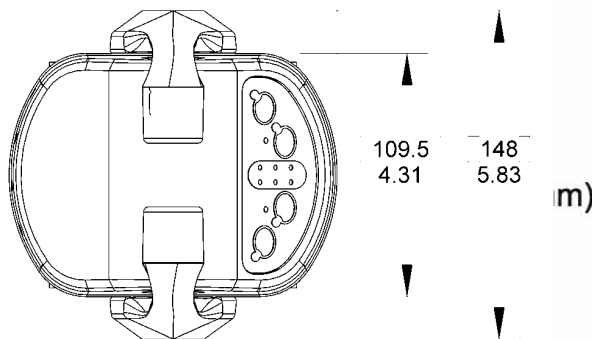
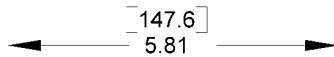
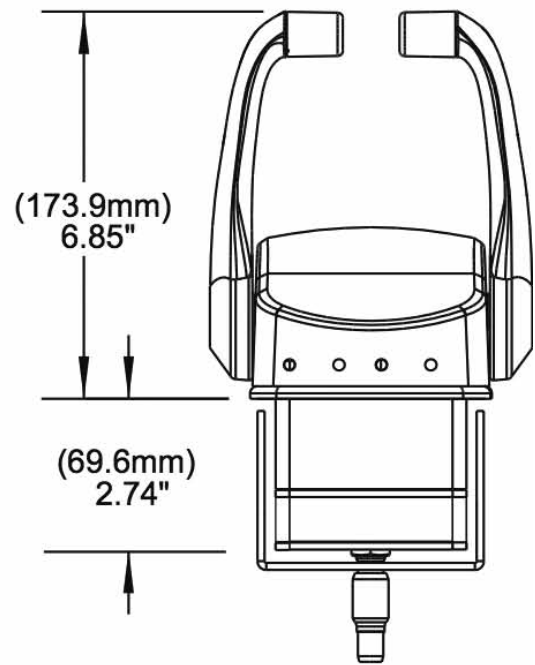
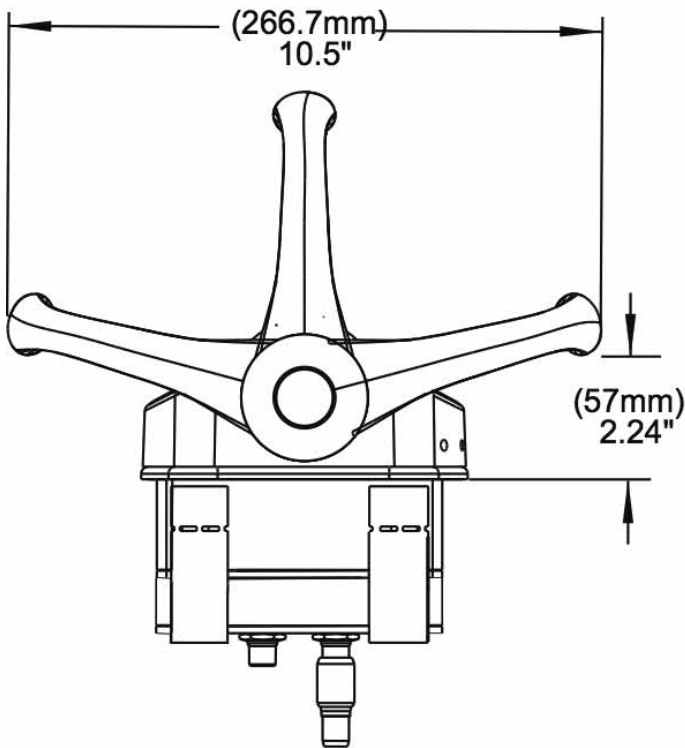
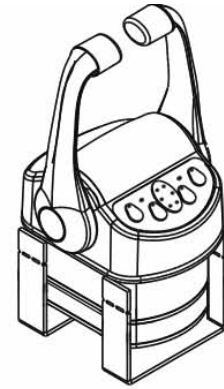

4-button Control Head (Remote) Dimensions

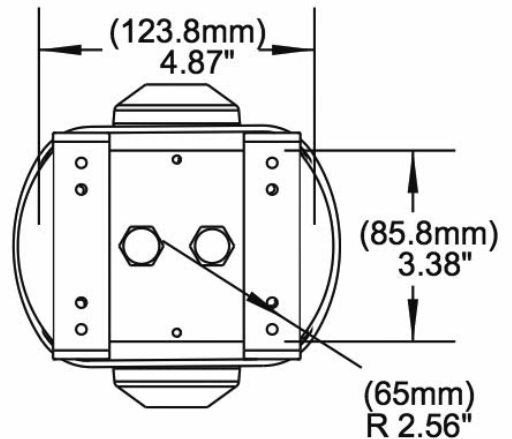
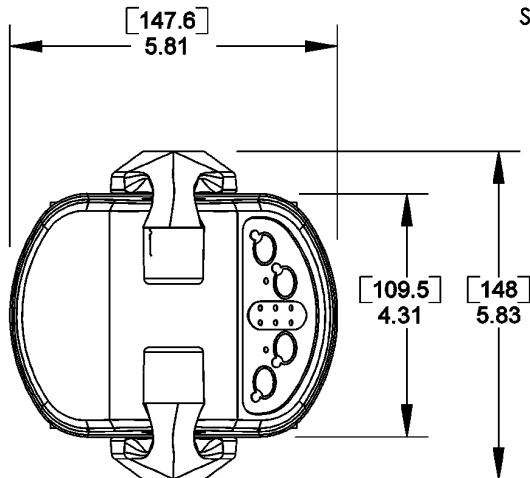
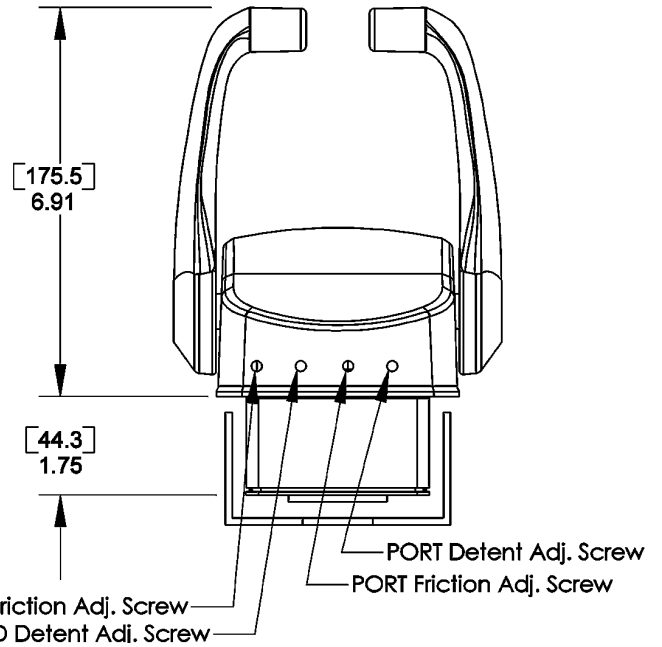
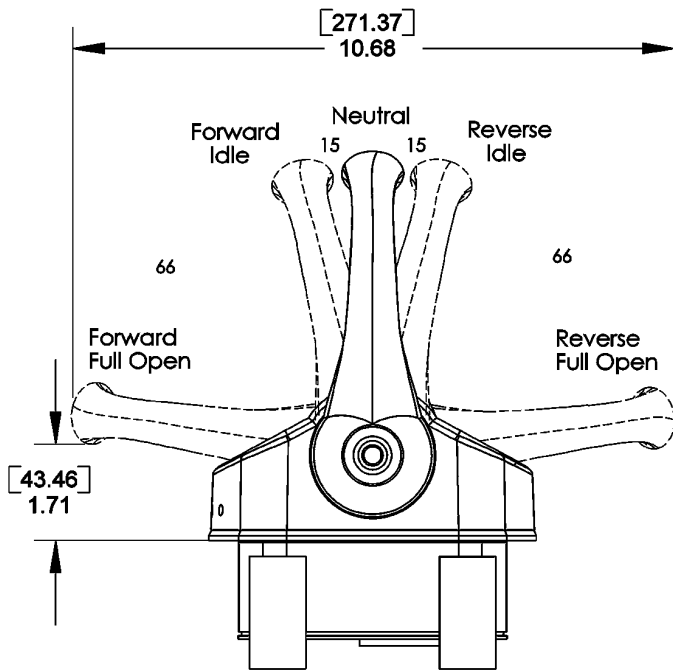
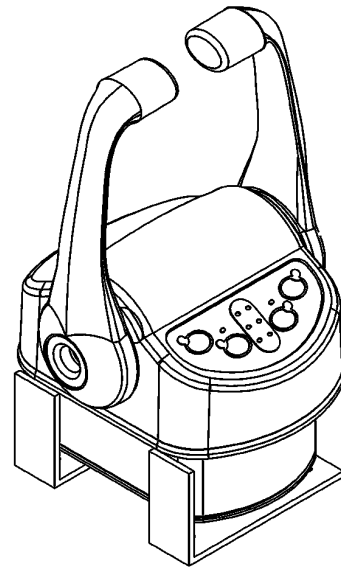

2-button Control Head (Remote) Cutout Template

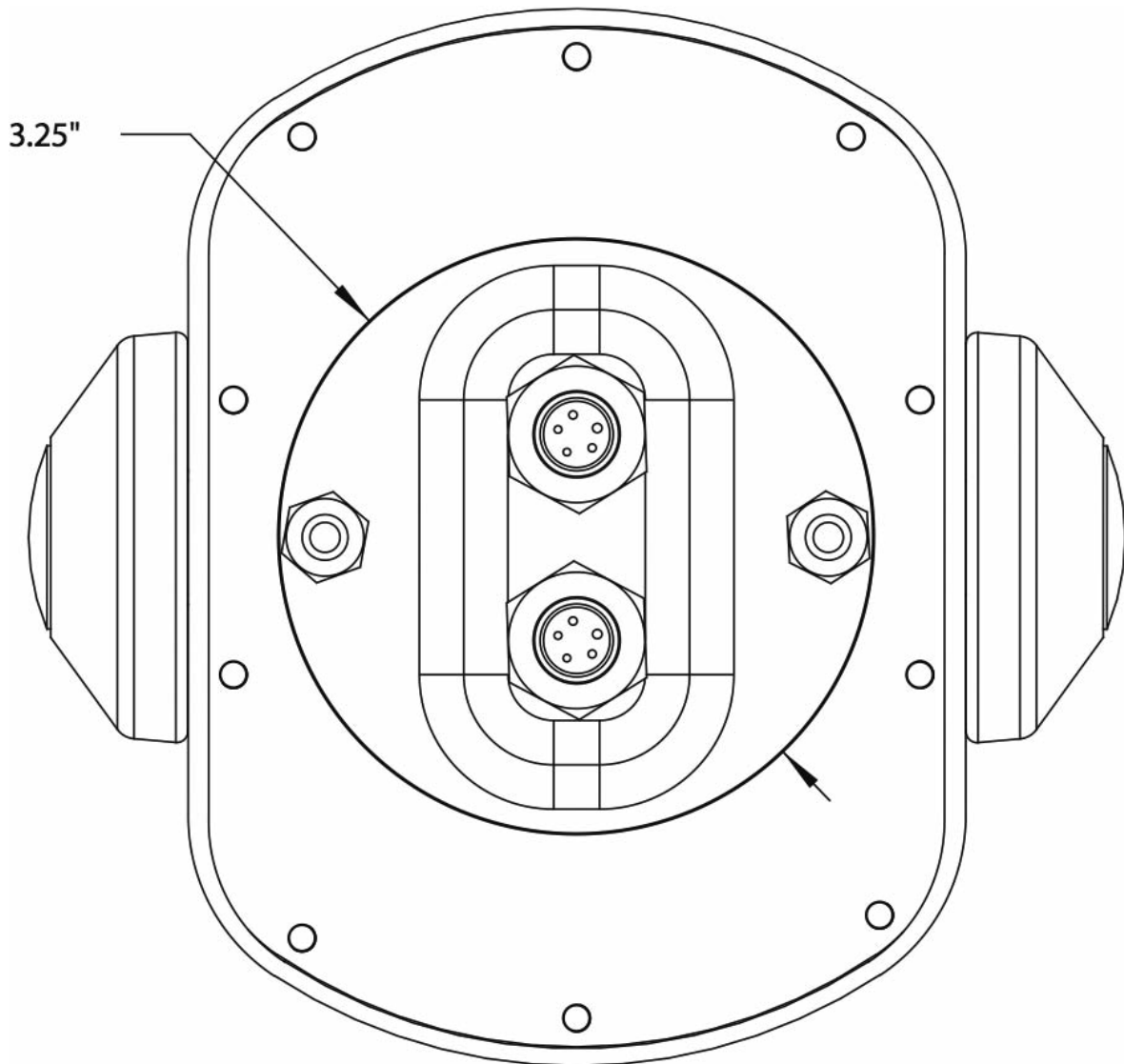

Control Head Cutout Template for:

- **2-button Control Head CP**
- **4-button Control Head (Remote)**
- **4-button Control Head CP**

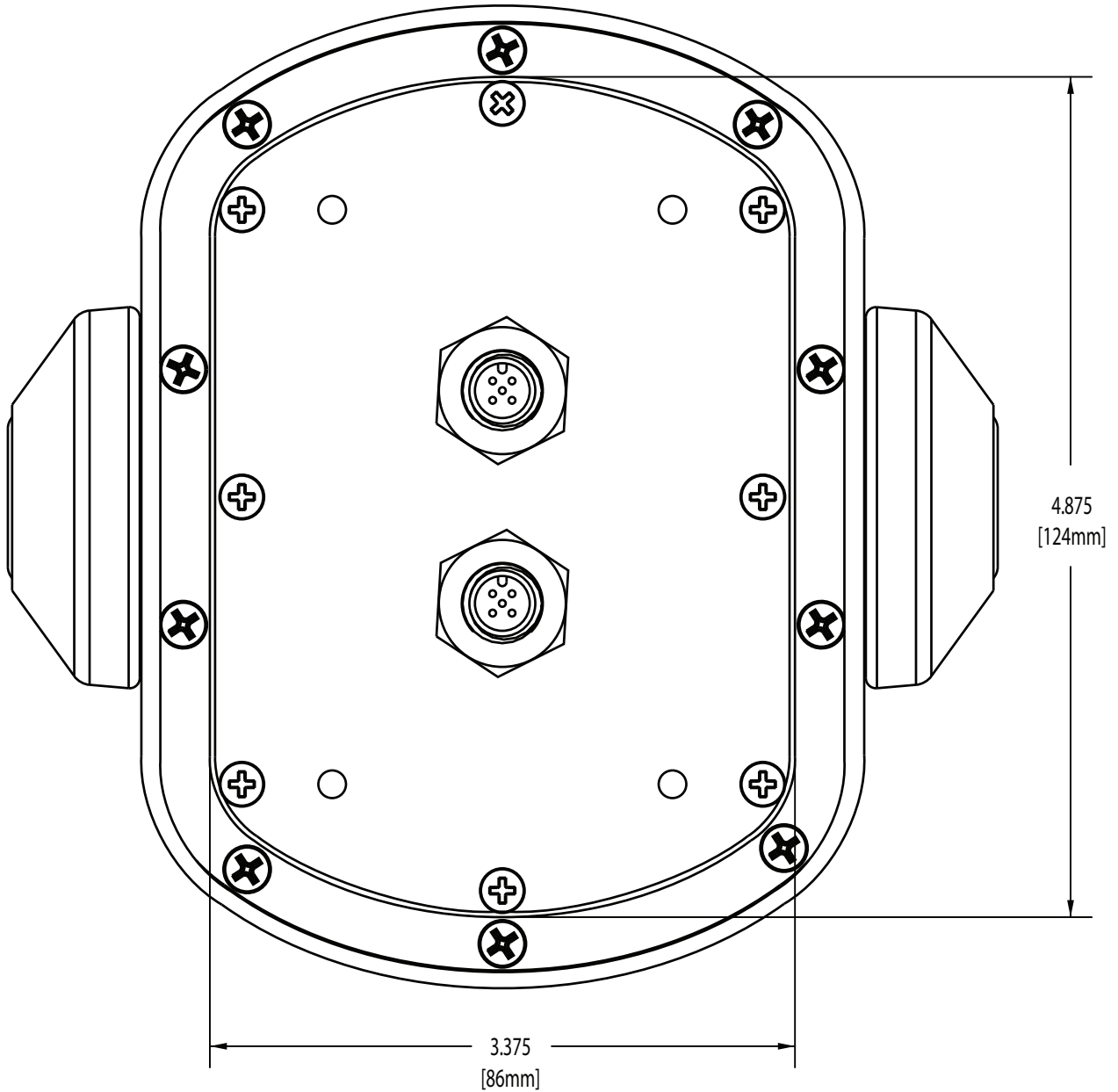

NOTE: IF PRINTING TEMPLATE FROM THE INTERNET MAKE SURE PRINTER DOES NOT "SHRINK TO FIT PAGE" OR DIMENSIONS WILL BE INACCURATE — CHECK BEFORE CUTTING CONSOLE!!

7.3 Sidemount Controls Installation (optional)

A. Sidemount Handle Control Assembly



Before installing the Sidemount Control Head Assembly consider:

There are 3 types of mounting options for the installation of Sidemount Controls. The major differences between these types of mounting options are the outside appearance of the console, and the difficulty of installation.

Mounting Option	Ease of Installation	Description
Bezel on the Outside of Console	Simple	A bezel and the sidemount control handle are visible on the exterior of the console
Bezel on the Inside of the Console	Hard	Bezel installed on the inside of the console, offers the most professional appearance with the control handle only being seen on the exterior of the console
No Bezel	Difficult	Control Head shaft and handle are visible on the exterior of the console

● Outside Console Bezel Mounting

STEP 1: Determine location of bezel hole in console by placing bezel on outside of console where desired and mark the 1-1/4" hole and the 1/4" clearance holes, (see figure 8) (NOTE: Clearance for control head needs to be determined on inside of console before cutting holes; Make sure to use the correct control head mechanism PORT or STBD when planning the hole locator. Notice location of friction control adjustment screws in respect to console placement!).

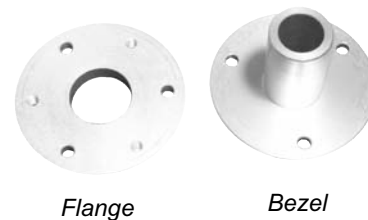

STEP 2: Use 1-1/4" hole saw to cut center hole and drill 17/64" holes for outside flange mounting (see figure 9).

STEP 3: Place outside flange in 1-1/4" hole and place inside flange over small diameter of outside flange on inside of console. Tighten flanges together with 1/4" x 20 flat head screws (see figure 10) (NOTE: Depending on console thickness, a small diameter of outside flange and 1/4" x 20 flat head screws may need to be shortened).

STEP 4: Once Outside Flange and Inside Flange are mounted, install (3) #10 flat head wood screws through Inside Flange. This will hold the Inside Flange in place in case of removal in the future (see figure 11) (NOTE: Wood screws should not be longer than the thickness of the console).

STEP 5: Install the Control Head mechanism in flange (see figure 12) (NOTE: The control heads are marked Port and Stb.; Adjustment screws should face forward).

STEP 6: Establish the desired control head angle according to the clearance in the console (see figure 13).

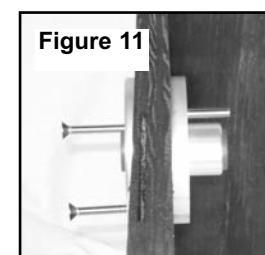
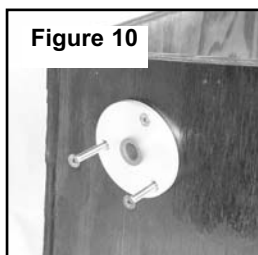
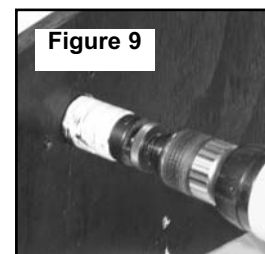
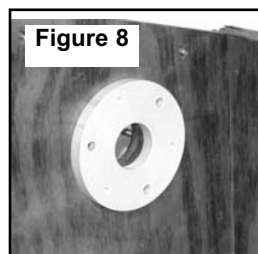

STEP 7: Threaded rod with ball joints are to be attached to head and console at this point (see figure 13) (NOTE: Angle of 90 degrees is best for most support).

STEP 8: Install control handle and key (where applicable) and tighten set screw down to mark shaft. Fine alignment of handles may be adjusted by shortening or lengthening threaded rod (see figure 14) (NOTE: Shaft end play between handle and console should be less than 1/8" [see figure 15]).

STEP 9: Remove set screw and handle and divot shaft using same size drill as the set screw.

STEP 10: Reinstall control handle and use two set screws, on top of each other.

● Inside Console Bezel Mounting

STEP 1: To determine location of inside bezel mount, caution should be exercised to ensure proper placement of bezel prior to cutting hole in the console (NOTE: This is determined by the clearance of the control head on the inside of the console).

STEP 2: Using the "inner bezel" as a template, trace the 1-1/4" center hole onto the inside wall of the console (see figure 16).

STEP 3: Cut out the 1-1/4" center hole and drill (3) #10 starter holes being careful NOT to drill through the wall of the console.

STEP 4: Place inner bezel onto the outer bezel shaft and insert assembly into the 1-1/4" cutout hole. Tighten (3) #10 wood screws into flange where indicated (see figure 17) (NOTE: make sure to use screw lengths that DO NOT exceed the thickness of the console).

STEP 5: Bezel outside of console can now be marked flush so the excess can be removed. This allows no bezel to be seen on outside of console. Remove bezel from console. Remove red bushing from inside of bezel and trim bezel.

STEP 6: Reinstall red bushing in bezel and insert bezel into hole in console. Tighten (3) #10 wood screws into flange where indicated (see figure 18) (NOTE: make sure to use screw lengths that DO NOT exceed the thickness of the console).

STEP 7: Install the control head shaft into the flange assembly.

STEP 8: Establish the desired control head angle according to the clearance in the console.

STEP 9: Threaded rod with ball joints are to be attached to head and console at this point (NOTE: Angle of 90 degrees is best for most support) (see figure 19).

STEP 10: Install control handle and key (where applicable) and tighten set screw down to mark shaft. Fine alignment of handles may be adjusted by shortening or lengthening threaded rod (NOTE: Shaft end play between handle and console should be less than 1/8") (see figure 20).

STEP 11: Remove set screw and handle and divot shaft using same size drill as the set screw.

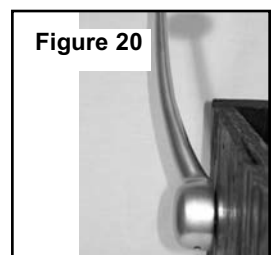
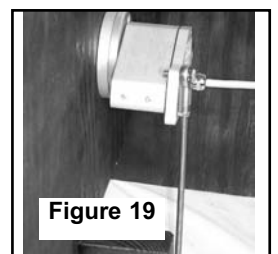
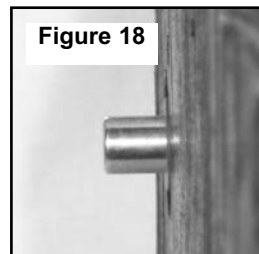
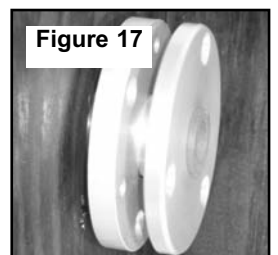
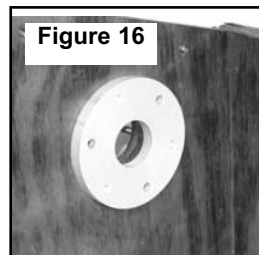
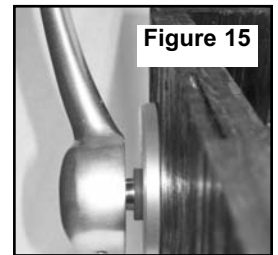
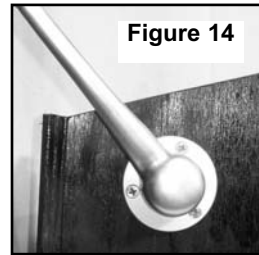
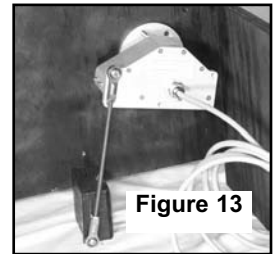
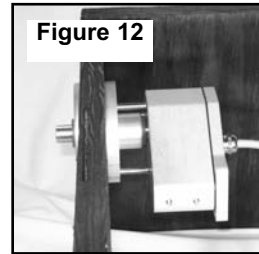

STEP 12: Reinstall control handle and use two set screws, on top of each other.

To mount control handles without Bezel mounting kit:

STEP 1: The control head has one face opposite handle shaft with 1/4 threaded holes to mount to inside face of console.

STEP 2: The 1/4 threaded holes can also be used to mount the control head to a bracket of your design, to attach head to some other locations in console.

STEP 3: When method of mounting is determined, keep a these things in mind—The length of shaft outside of console and the free movement of the shaft.

B. Sidemount Keypad Assembly

Before mounting the Sidemount Keypad Assembly, inspect the surface that the Keypad is to be mounted to. It should be flat and reasonably strong enough to support the Keypad securely.

STEP 1: Mark the location for the Keypad Assembly using the full size template (see page 59). Cut the 1-3/4" x 4" keypad assembly cutout.

STEP 2: Insert the connection cable from the Sidemount Control Handle pod and the Station Cable (that leads to the Control Processor) through the console cutout and attach to the keypad assembly. The control head pods are marked PORT and STBD and must be installed in the proper connector.

STEP 3: Install Control Head clamps and tighten wing nuts provided. Make sure Keypad Assembly is firmly mounted to console.

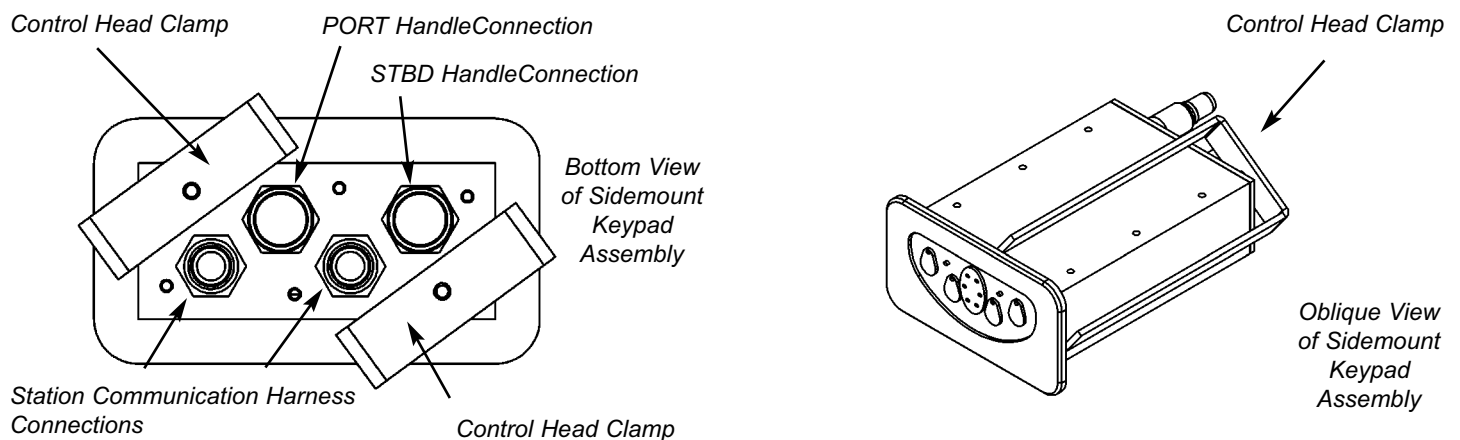
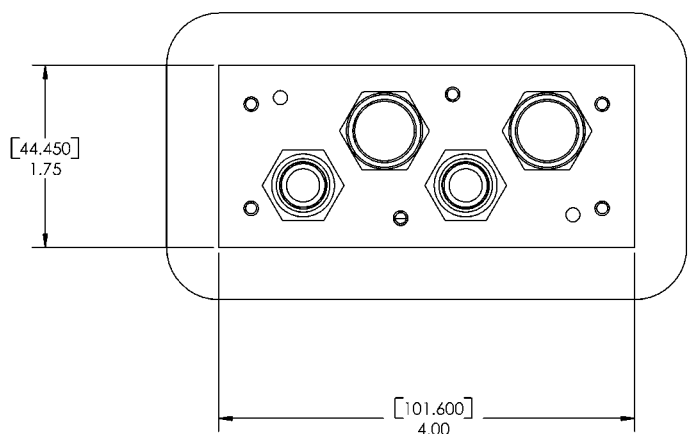

STEP 4: Connect the Sidemount Control Head Assembly (PORT and STBD) to the Sidemount Keypad Assembly at the PORT Handle and STBD Handle Connections (see diagram above). Connect the Station Communication Harness from the Control Processor to the Station Communication Connections on the Keypad Assembly (see diagram above). Depending on your network's configuration a Station Communication Harness or a Terminating Resistor must be installed at both Station Communication Connections on the Keypad Assembly.

Sidemount Handle Control Dimensions

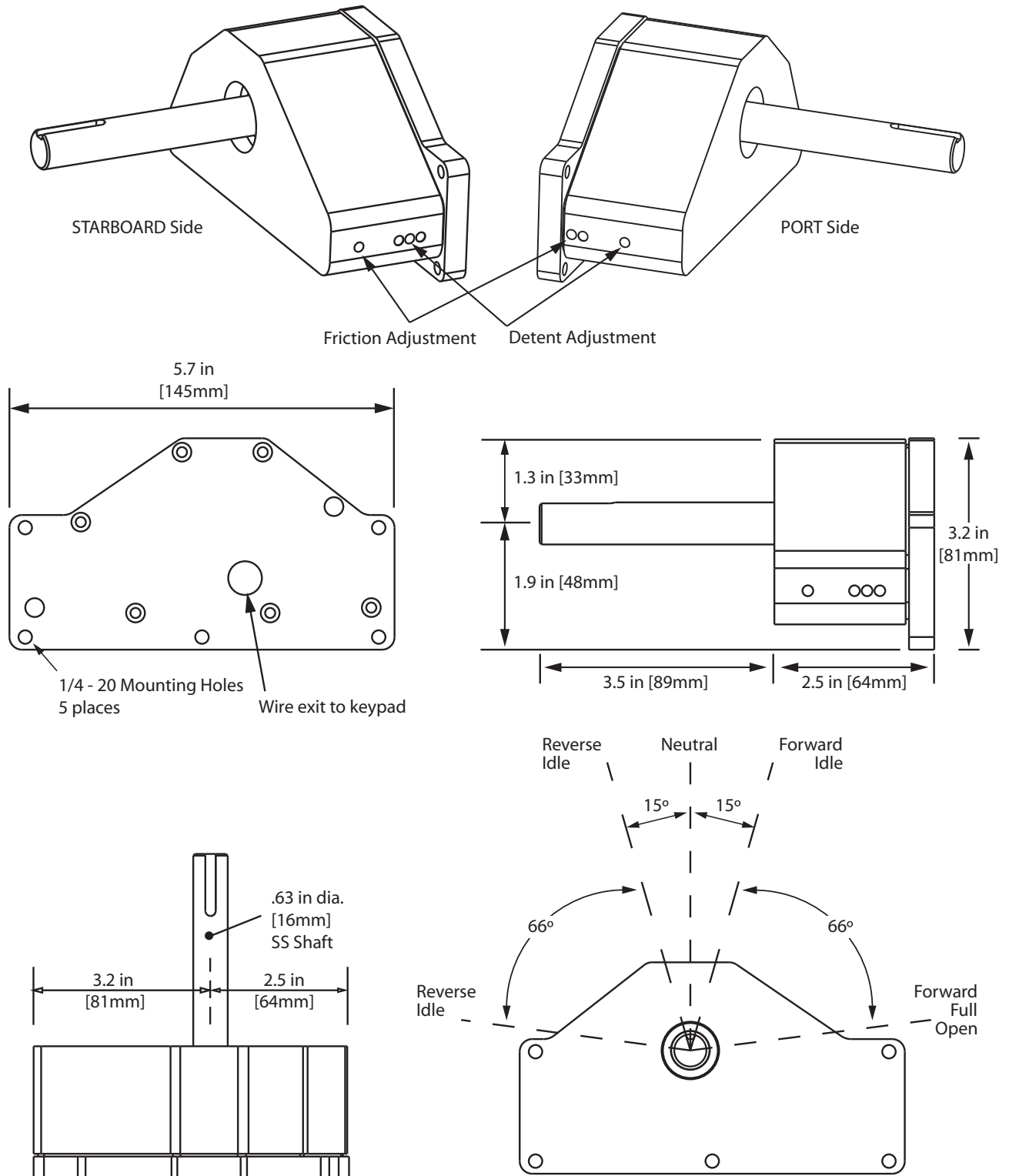

(STARBOARD Side Handle Shown)

Sidemount Keypad Assembly Dimensions

EEC3 SIDEMOUNT KEYPAD ASSEMBLY

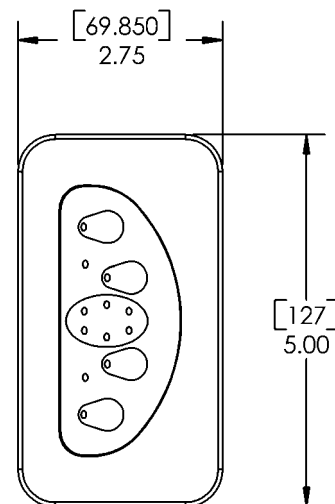
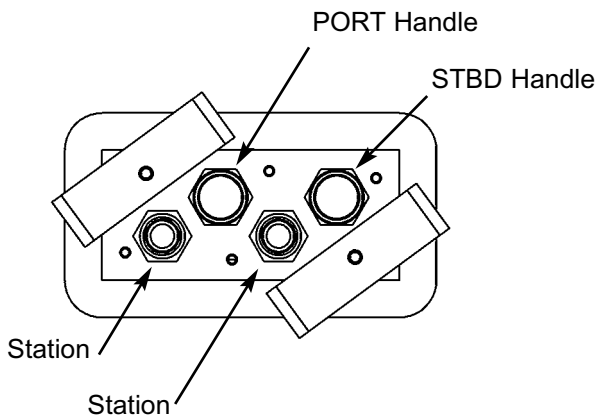
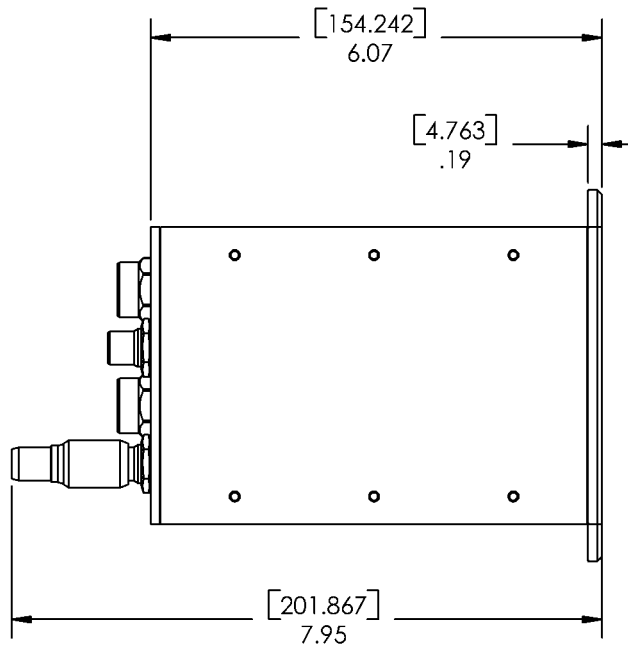
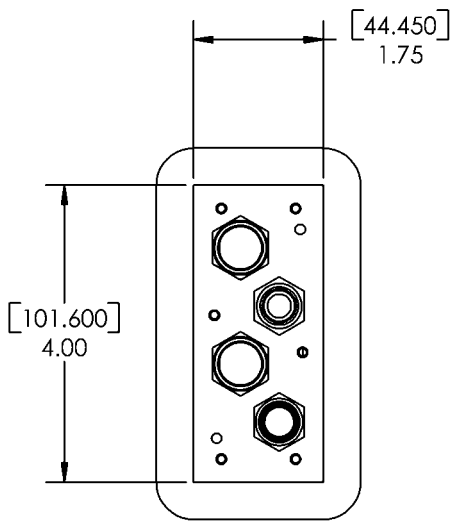
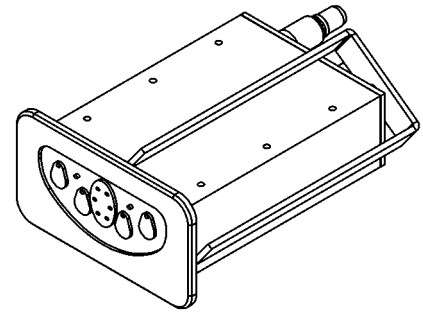

Sidemount Keypad Assembly Wiring Connections

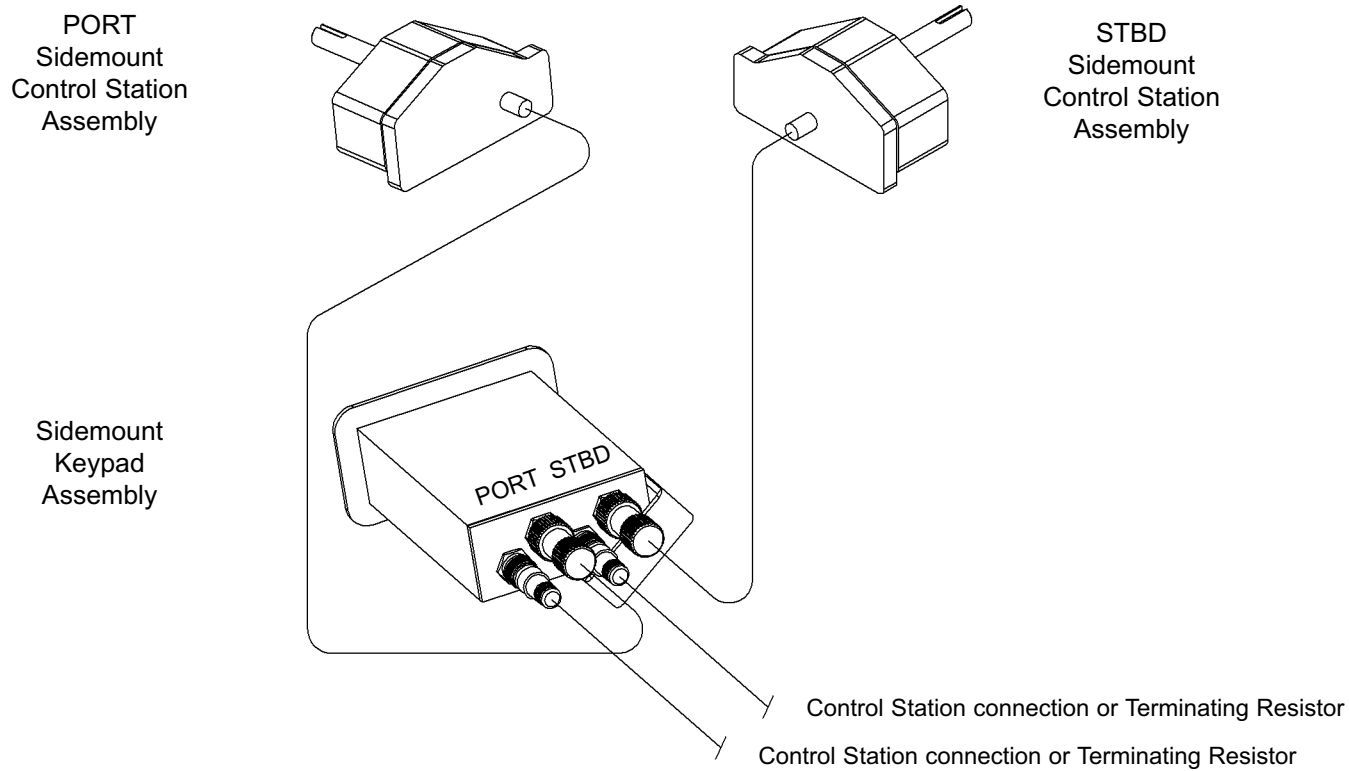

Sidemount Handle Assembly Mounting

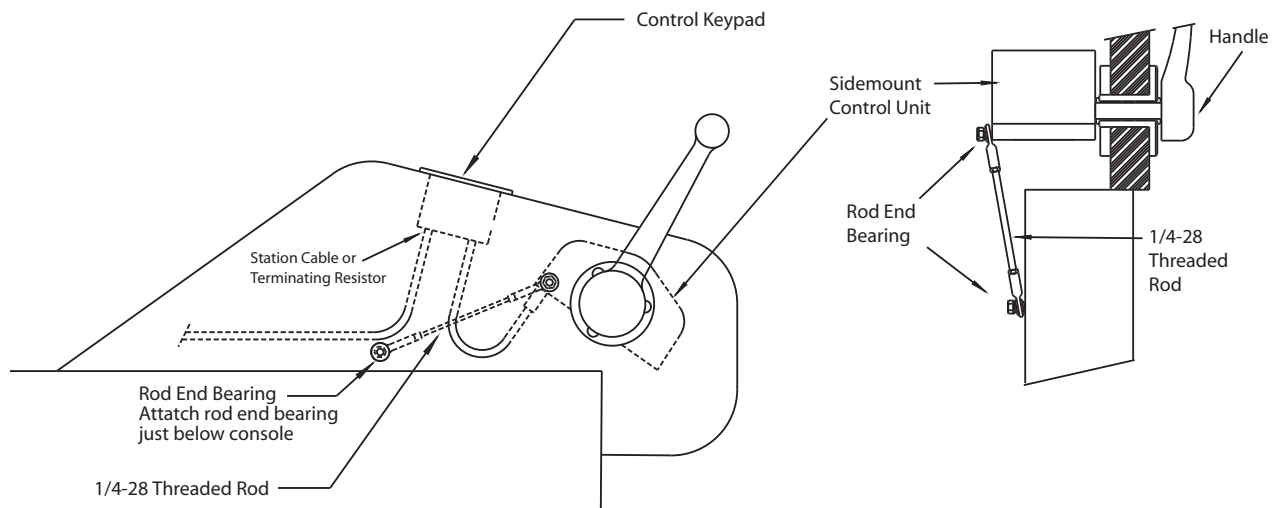

Cutout Template for Sidemount Keypad Assembly

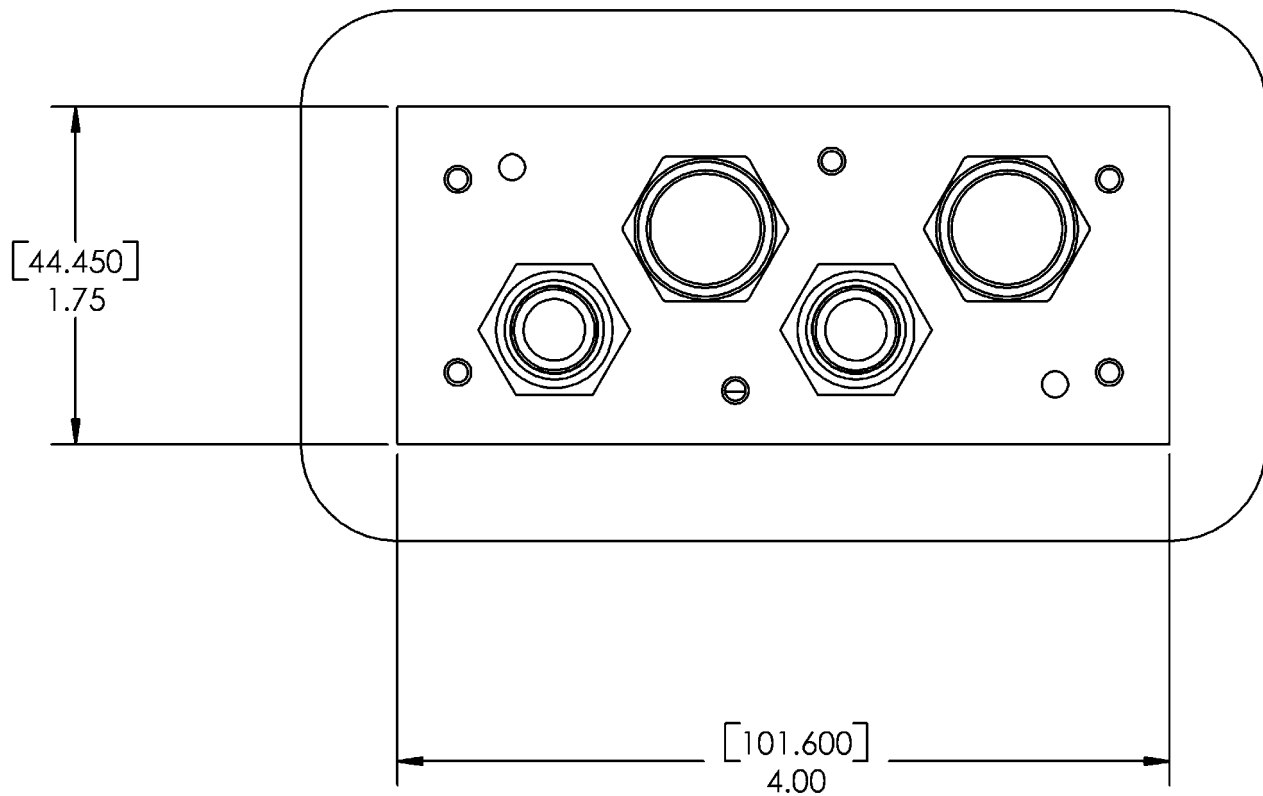

7.4 Control Head Configuration (Setting Control Handle ID's)

In order for each Control Head to communicate with the Control Processor, each Control Head must have a unique Handle Identifier. If you purchased a complete system, configuration and handle identification was performed by the factory.

If you purchased a control head **separately**, you will NEED to set the handle identifier for that control station. Follow the 8 steps below:

To Change Handle Identifier, Follow These 8 Steps:



1	ACTION	RESULT
	<p>Move control station handles to FULL ASTERN positions</p>	<p>No result</p>
	<p>Turn power ON to the system</p>	<p>TAKE LED will begin to flash</p>
	<p>4 BUTTON: Press & HOLD the 2 center buttons (SYNC & WARM) for approximately 2 seconds until all 4 LEDs begin to flash-RELEASE buttons</p> <p>2-BUTTON: Press & Hold BOTH buttons as outlined above</p>	<p>All 4 LEDs begin to flash</p>
	<p>4 BUTTON: Press & Release the SYNC button one time to select Handle Identifier Mode</p> <p>2-BUTTON: Press and Release the ACTIVE button one time</p>	<p>TAKE LED will begin to flash</p>
	<p>4 BUTTON: Press & Release the WARM button one time to enter Handle ID Configuration</p> <p>2-BUTTON: Press and Release the WARM / SYNC button</p>	<p>TAKE LED will be illuminated</p>

Chart is continued on next page . . .

<p>6</p> 	<p>ACTION</p> <p>4 BUTTON: Press & Release SYNC button until desired handle ID is achieved — see chart at right for ID# and corresponding LED that is illuminated</p> <p>2-BUTTON: Press & Release the ACTIVE button as indicated above</p>	<p>RESULT</p>			
		ID#	4-button LEDs ON	2-button LEDs ON	
		1	TAKE	PORT Neutral	
		2	SYNC	ACTIVE	
		3	TAKE & SYNC	PORT Neutral & ACTIVE	
		4	WARM	WARM	
		5	TAKE & WARM	PORT Neutral & WARM	
6	SYNC & WARM	ACTIVE & WARM			
<p>7</p> 	<p>4 BUTTON: Press & Release the WARM button one time</p> <p>2-BUTTON: Press & Release the WARM / SYNC buttons one time</p>	<p>This action stores your handle ID in memory. All 4 LEDs begin to flash after ID is stored in memory</p>			
<p>8</p> 	<p>RECORD the Handle ID# on the tag located on the bottom of the Control Head</p>	<p>N/A</p>			
<p>To Exit Control Handle Configuration Mode — turn system OFF and return control handles to NEUTRAL position.</p>					

7.5 Control Processor Functional Configuration

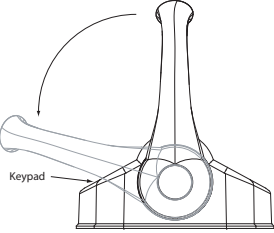
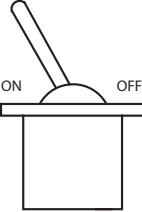
Configuration of the Smart Actuator II™ system was performed at GMP from the information the ship operator gave at the time the order was placed. Changes to the Control Processor functional configuration, although not frequently done, can be made to suit operator preference and is entered from the **control head keypad**. Follow the instructions for each option when making changes.

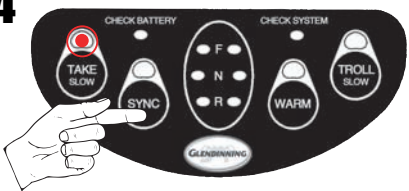
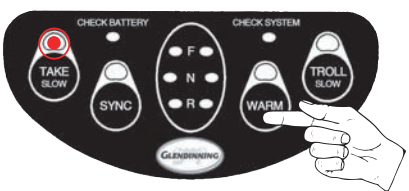
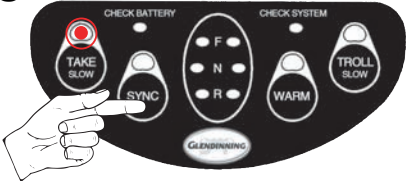
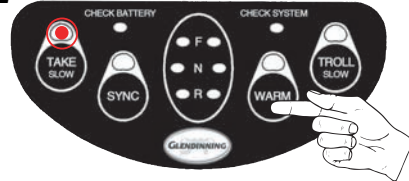
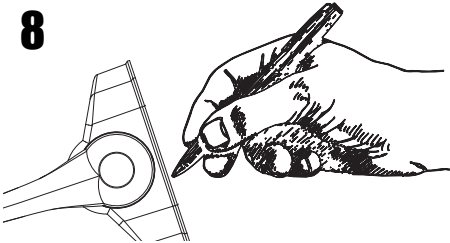
To Enter System Configuration Mode, follow these steps:

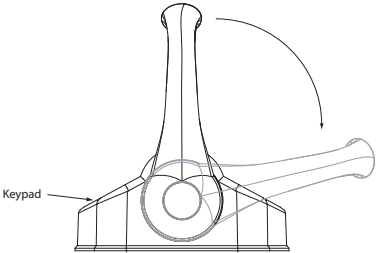
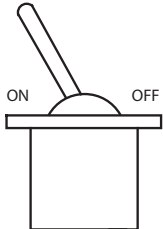
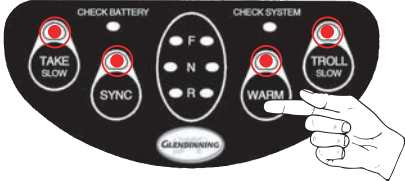
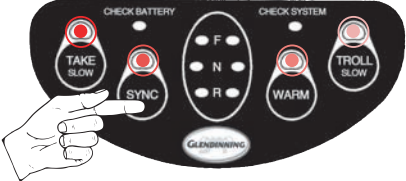
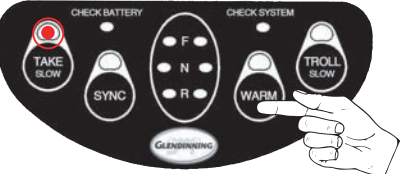
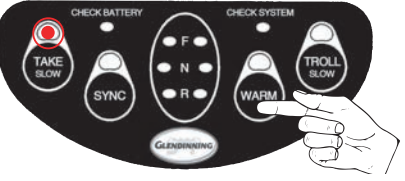
	ACTION	RESULT
	<p>Move control station handles to FULL THROTTLE positions</p>	<p>No result</p>
	<p>Turn power ON to the system</p>	<p>TAKE LED will begin to flash</p>
	<p>Press & Release the WARM button 3 times</p>	<p>All 4 LEDs begin to flash</p>
	<p>Press & Release the SYNC button the number of times as outlined on pages 74-90 for particular System Configuration Option you wish to change</p>	<p>Appropriate LED will be illuminated (see pages 74-90 for LED illumination)</p> <ul style="list-style-type: none"> Actuator Optionspg. 74 Throttle on Top of Troll Optionspg. 75 Troll Delay Optionspg. 76 Throttle Delay Optionspg. 77 Fixed Gear Delay Optionspg. 78 High-Idle Step Size Options, PT 1pg. 79 High-Idle Step Size Options, PT 2pg. 80 SystemStartup Mode Optionspg. 81 Station Transfer Optionspg. 82 Set Configuration Settings to Defaultpg. 83 Sync Gain Optionspg.84 Neutral Delay Optionspg.85 Throttle Bump Amount Optionspg.86 Sync Master Select Optionspg.87 Throttle Curve Optionspg.88 Dynamic Gear Delay Optionspg. 90
	<p>Press & Release the WARM button one time to save your configuration changes in memory</p>	<p>Appropriate LED will be illuminated depending on which System Configuration Option you selected in Step 4 above.</p>



7.5.1 Actuator Options

The Actuator Option allows you to select which actuator configuration your boat is equipped with:

<p>For boats equipped with Mechanical Throttle & Mechanical Gear use Option 1 below (default)</p>	<p>For boats equipped with Mechanical Throttle Mechanical Gear & Mechanical Troll use Option 2 below</p>	<p>For boats equipped with Mechanical Throttle & Electronic Gear use Option 3 below</p>	<p>For boats equipped with Mechanical Throttle Electronic Gear & Mechanical Troll use Option 4 below</p>
--	---	--	---

Actuator Option default is set for Mechanical Throttle & Mechanical Gear unless you specified troll option at time of placing order with GMP— if your boat is equipped with trolling vavles and you forgot to inform us, you will need to change this configuration option

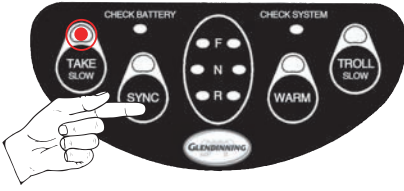
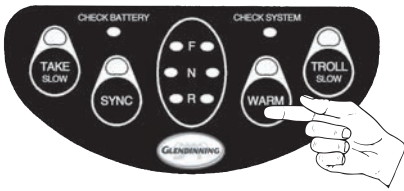
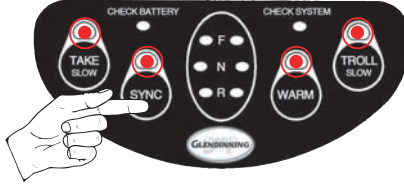
To Change Actuator Option Setting Follow These Steps:

<i>Enter Configuration Mode as described in section 7.5 (pg. 73)</i>																									
ACTION	RESULT																								
	<p>Press & Release SYNC button 1 time for Actuator Options</p> <p style="text-align: center;">TAKE LED will begin to flash</p>																								
	<p>Press & Release WARM button 1 time to activate selection</p> <p style="text-align: center;"><i>LEDs for Current Actuator Option will be displayed</i></p> <table border="1" style="width: 100%; text-align: center;"> <thead> <tr> <th></th> <th style="text-align: center;">LEDs ON</th> <th style="text-align: center;">ACTUATOR OPTION</th> </tr> </thead> <tbody> <tr> <td style="text-align: center;">1</td> <td style="text-align: center;">TAKE</td> <td style="text-align: center;">Mechanical Throttle Mechanical Gear (default)</td> </tr> <tr> <td style="text-align: center;">2</td> <td style="text-align: center;">SYNC</td> <td style="text-align: center;">Mechanical Throttle Mechanical Gear Mechanical Troll</td> </tr> <tr> <td style="text-align: center;">3</td> <td style="text-align: center;">TAKE & SYNC</td> <td style="text-align: center;">Mechanical Throttle Electronic Gear</td> </tr> <tr> <td style="text-align: center;">4</td> <td style="text-align: center;">WARM</td> <td style="text-align: center;">Mechanical Throttle Electronic Gear Mechanical Troll</td> </tr> <tr> <td style="text-align: center;">5</td> <td style="text-align: center;">TAKE & WARM</td> <td style="text-align: center;">3-ENGINE Mechanical Throttle & Gear Center follows STBD</td> </tr> <tr> <td style="text-align: center;">6</td> <td style="text-align: center;">SYNC & WARM</td> <td style="text-align: center;">3-ENGINE Mechanical Throttle & Gear Center follows PORT</td> </tr> <tr> <td style="text-align: center;">7</td> <td style="text-align: center;">TAKE, SYNC & WARM</td> <td style="text-align: center;">SINGLE ENGINE Mechanical Throttle & Gear</td> </tr> </tbody> </table>		LEDs ON	ACTUATOR OPTION	1	TAKE	Mechanical Throttle Mechanical Gear (default)	2	SYNC	Mechanical Throttle Mechanical Gear Mechanical Troll	3	TAKE & SYNC	Mechanical Throttle Electronic Gear	4	WARM	Mechanical Throttle Electronic Gear Mechanical Troll	5	TAKE & WARM	3-ENGINE Mechanical Throttle & Gear Center follows STBD	6	SYNC & WARM	3-ENGINE Mechanical Throttle & Gear Center follows PORT	7	TAKE, SYNC & WARM	SINGLE ENGINE Mechanical Throttle & Gear
	LEDs ON	ACTUATOR OPTION																							
1	TAKE	Mechanical Throttle Mechanical Gear (default)																							
2	SYNC	Mechanical Throttle Mechanical Gear Mechanical Troll																							
3	TAKE & SYNC	Mechanical Throttle Electronic Gear																							
4	WARM	Mechanical Throttle Electronic Gear Mechanical Troll																							
5	TAKE & WARM	3-ENGINE Mechanical Throttle & Gear Center follows STBD																							
6	SYNC & WARM	3-ENGINE Mechanical Throttle & Gear Center follows PORT																							
7	TAKE, SYNC & WARM	SINGLE ENGINE Mechanical Throttle & Gear																							
	<p>Press & Release SYNC button repeatedly to cycle through Actuator Options, LED will illuminate according to selection chosen (see chart at right)</p>																								
	<p>Press & Release WARM button 1 time to save option selection in memory</p> <p style="text-align: center;">Once selection has been saved by pressing & releasing the WARM button, you may:</p> <p style="text-align: center;">1) continue to change other configuration options on the following pages OR . . .</p> <p style="text-align: center;">2) you may EXIT CONFIGURATION MODE by turning system OFF, moving control handles back to NEUTRAL, and then turn system ON again.</p>																								

7.5.2 Throttle on Top of Troll Options

The Throttle on Top of Troll Option allows you to configure the Smart Actuator II™™ system to give approximately 1/3 of throttle range after reaching troll full lock-up.

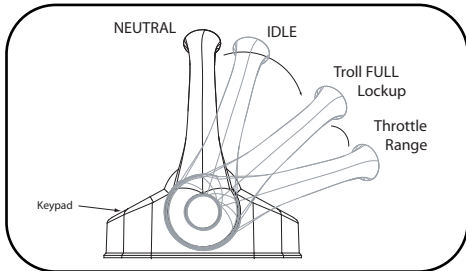

Moving handles past trolling valve full-lockup...

When throttle on top of troll is enabled

(Default = NO throttle on top of troll)

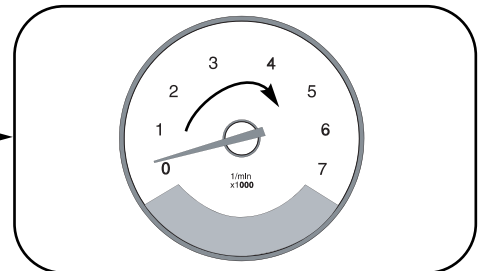

engine RPMs are increased up to 1/3 of normal throttle range

To Change Throttle on Top of Troll Option Setting Follow These Steps:

Enter Configuration Mode as described in section 7.5 (pg. 73)				
ACTION		RESULT		
		SYNC LED will begin to flash		
		LEDs for current Throttle on Top of Troll option will be displayed		
		1	LEDs ON	THROTTLE ON TOP OF TROLL OPTION
Press & Release SYNC button repeatedly to cycle through Throttle on Top of Troll Options, LED will illuminate according to selection chosen (see chart at right)			None	No Throttle on Top of Troll (default)
		2	TAKE	Throttle on Top of FULL Lockup
		Once selection has been saved by pressing & releasing the WARM button, you may: <ol style="list-style-type: none"> continue to change other configuration options on the following pages OR . . . you may EXIT CONFIGURATION MODE by turning system OFF, moving control handles back to NEUTRAL, and then turn system ON again. 		

7.5.3 Troll Delay Options

The Troll Delay option allows you to configure the Smart Actuator II™™ system to delay troll modulation as the system goes from gear shift to troll modulation.

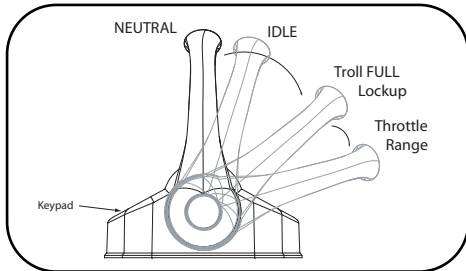

**Configurable
0-2.5 second
Delay**

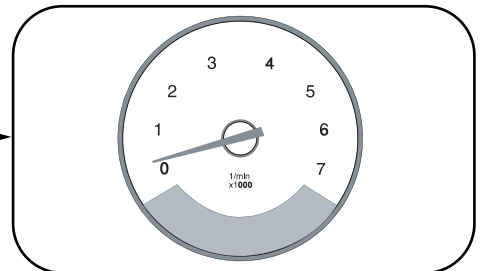

When in Troll Mode, moving handles in or out of the throttle on top of troll range ...

system will pause ... (Default = NO delay)

before engaging or disengaging trolling valves

To Change Troll Delay Option Settings Follow These Steps:

<i>Enter Configuration Mode as described in section 7.5 (pg. 73)</i>																								
ACTION		RESULT																						
	<p><i>Press & Release SYNC button 3 time for Troll Delay Options</i></p>	<p><i>TAKE & SYNC LEDs will begin to flash</i></p>																						
	<p><i>Press & Release WARM button 1 time to activate selection</i></p>	<p><i>LEDs for current Troll Delay option will be displayed</i></p>																						
	<p><i>Press & Release SYNC button repeatedly to cycle through Troll Delay Options, LED will illuminate according to selection chosen (see chart at right)</i></p>	<table border="1"> <thead> <tr> <th></th> <th style="text-align: center;">LEDs ON</th> <th style="text-align: center;">TROLL DELAY OPTION</th> </tr> </thead> <tbody> <tr> <td style="text-align: center;">1</td> <td style="text-align: center;">None</td> <td style="text-align: center;">No Troll Delay (default)</td> </tr> <tr> <td style="text-align: center;">2</td> <td style="text-align: center;">TAKE</td> <td style="text-align: center;">0.5 second delay</td> </tr> <tr> <td style="text-align: center;">3</td> <td style="text-align: center;">SYNC</td> <td style="text-align: center;">1.0 second delay</td> </tr> <tr> <td style="text-align: center;">4</td> <td style="text-align: center;">TAKE & SYNC</td> <td style="text-align: center;">1.5 second delay</td> </tr> <tr> <td style="text-align: center;">5</td> <td style="text-align: center;">WARM</td> <td style="text-align: center;">2.0 second delay</td> </tr> <tr> <td style="text-align: center;">6</td> <td style="text-align: center;">TAKE & WARM</td> <td style="text-align: center;">2.5 second delay</td> </tr> </tbody> </table>		LEDs ON	TROLL DELAY OPTION	1	None	No Troll Delay (default)	2	TAKE	0.5 second delay	3	SYNC	1.0 second delay	4	TAKE & SYNC	1.5 second delay	5	WARM	2.0 second delay	6	TAKE & WARM	2.5 second delay	
	LEDs ON	TROLL DELAY OPTION																						
1	None	No Troll Delay (default)																						
2	TAKE	0.5 second delay																						
3	SYNC	1.0 second delay																						
4	TAKE & SYNC	1.5 second delay																						
5	WARM	2.0 second delay																						
6	TAKE & WARM	2.5 second delay																						
	<p><i>Press & Release WARM button 1 time to save option selection in memory</i></p>	<p><i>Once selection has been saved by pressing & releasing the WARM button, you may:</i></p> <p><i>1) continue to change other configuration options on the following pages OR . . .</i></p> <p><i>2) you may EXIT CONFIGURATION MODE by turning system OFF, moving control handles back to NEUTRAL, and then turn system ON again.</i></p>																						

7.5.4 Throttle Delay Options

The Throttle Delay Option allows you to configure the Smart Actuator II™™ system to delay throttle output as you shift from Neutral, past in-gear idle, and into the throttle range.

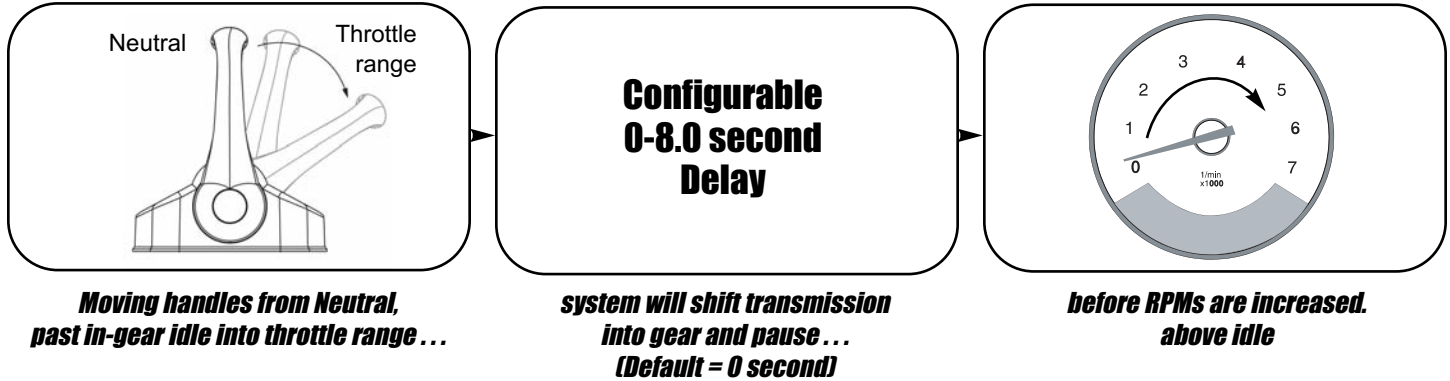

To Change Throttle Delay Setting Follow These Steps:

Enter Configuration Mode as described in section 7.5 (pg. 73)		
ACTION	RESULT	
<p>Press & Release SYNC button 4 times for Throttle Delay Option</p>	WARM LED will begin to flash	
<p>Press & Release WARM button 1 time to activate selection</p>	LEDs for current Throttle Delay option will be displayed	
<p>Press & Release SYNC button repeatedly to cycle through Throttle Delay Options, LED will illuminate according to selection chosen (see chart at right)</p>	<p>NO throttle delay (default)</p> <p>0.5 Second Delay TAKE LED ON</p> <p>1.0 Second Delay SYNC LED ON</p> <p>1.5 Second Delay TAKE & SYNC LED ON</p> <p>2.0 Second Delay WARM LED ON</p> <p>2.5 Second Delay TAKE & WARM LED ON</p> <p>3.0 Second Delay SYNC & WARM LED ON</p> <p>3.5 Second Delay TAKE, SYNC, & WARM LED ON</p> <p>4.0 Second Delay TROLL LED ON</p> <p>4.5 Second Delay TAKE & TROLL LED ON</p> <p>5.0 Second Delay SYNC & TROLL LED ON</p> <p>5.5 Second Delay TAKE, SYNC, & TROLL LED ON</p> <p>6.0 Second Delay WARM & TROLL LED ON</p> <p>6.5 Second Delay TAKE, WARM, & TROLL LED ON</p> <p>7.0 Second Delay SYNC, WARM, & TROLL LED ON</p> <p>8.0 Second Delay ALL 4 LEDS ON</p>	
<p>Press & Release WARM button 1 time to save option selection in memory</p>	<p>Once selection has been saved by pressing & releasing the WARM button, you may:</p> <ol style="list-style-type: none"> 1) continue to change other configuration options on the following pages OR . . . 2) you may EXIT CONFIGURATION MODE by turning system OFF, moving control handles back to NEUTRAL, and then turn system ON again. 	

7.5.5 Fixed Gear Delay Options

The Fixed Gear Delay Option allows you to configure the Smart Actuator II™™ system to remain in gear for a fixed amount of time when the system goes from the throttle range to neutral, to allow throttle to reach idle before shifting transmission. The total gear delay time is the Fixed Gear Delay time plus the Dynamic Gear Delay time. The total gear delay is the sum of the dynamic gear delay and the fixed gear delay (see Sec. 7.5.18).

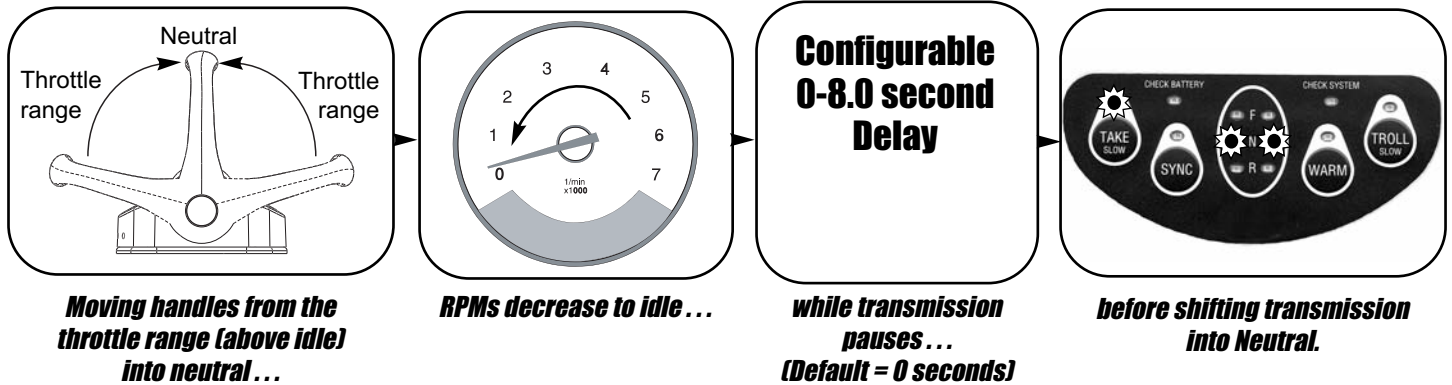

To Change Gear Delay Setting Follow These Steps:

Enter Configuration Mode as described in section 7.5 (pg. 73)																																																		
ACTION	RESULT																																																	
	Press & Release SYNC button 5 times for Gear Delay Option	TAKE & WARM LEDs will begin to flash																																																
	Press & Release WARM button 1 time to activate selection	LEDs for current Gear Delay option will be displayed																																																
	Press & Release SYNC button repeatedly to cycle through Gear Delay Options, LED will illuminate according to selection chosen (see chart at right)	<table border="0"> <tr> <td>NO delay (default)</td> <td>.....</td> <td>TAKE LED ON</td> </tr> <tr> <td>0.5 Second Delay</td> <td>.....</td> <td>TAKE LED ON</td> </tr> <tr> <td>1.0 Second Delay</td> <td>.....</td> <td>SYNC LED ON</td> </tr> <tr> <td>1.5 Second Delay</td> <td>.....</td> <td>TAKE & SYNC LED ON</td> </tr> <tr> <td>2.0 Second Delay</td> <td>.....</td> <td>WARM LED ON</td> </tr> <tr> <td>2.5 Second Delay</td> <td>.....</td> <td>TAKE & WARM LED ON</td> </tr> <tr> <td>3.0 Second Delay</td> <td>.....</td> <td>SYNC & WARM LED ON</td> </tr> <tr> <td>3.5 Second Delay</td> <td>.....</td> <td>TAKE, SYNC, & WARM LED ON</td> </tr> <tr> <td>4.0 Second Delay</td> <td>.....</td> <td>TROLL LED ON</td> </tr> <tr> <td>4.5 Second Delay</td> <td>.....</td> <td>TAKE & TROLL LED ON</td> </tr> <tr> <td>5.0 Second Delay</td> <td>.....</td> <td>SYNC & TROLL LED ON</td> </tr> <tr> <td>5.5 Second Delay</td> <td>.....</td> <td>TAKE, SYNC, & TROLL LED ON</td> </tr> <tr> <td>6.0 Second Delay</td> <td>.....</td> <td>WARM & TROLL LED ON</td> </tr> <tr> <td>6.5 Second Delay</td> <td>.....</td> <td>TAKE, WARM, & TROLL LED ON</td> </tr> <tr> <td>7.0 Second Delay</td> <td>.....</td> <td>SYNC, WARM, & TROLL LED ON</td> </tr> <tr> <td>8.0 Second Delay</td> <td>.....</td> <td>ALL 4 LEDS ON</td> </tr> </table>	NO delay (default)	TAKE LED ON	0.5 Second Delay	TAKE LED ON	1.0 Second Delay	SYNC LED ON	1.5 Second Delay	TAKE & SYNC LED ON	2.0 Second Delay	WARM LED ON	2.5 Second Delay	TAKE & WARM LED ON	3.0 Second Delay	SYNC & WARM LED ON	3.5 Second Delay	TAKE, SYNC, & WARM LED ON	4.0 Second Delay	TROLL LED ON	4.5 Second Delay	TAKE & TROLL LED ON	5.0 Second Delay	SYNC & TROLL LED ON	5.5 Second Delay	TAKE, SYNC, & TROLL LED ON	6.0 Second Delay	WARM & TROLL LED ON	6.5 Second Delay	TAKE, WARM, & TROLL LED ON	7.0 Second Delay	SYNC, WARM, & TROLL LED ON	8.0 Second Delay	ALL 4 LEDS ON
NO delay (default)	TAKE LED ON																																																
0.5 Second Delay	TAKE LED ON																																																
1.0 Second Delay	SYNC LED ON																																																
1.5 Second Delay	TAKE & SYNC LED ON																																																
2.0 Second Delay	WARM LED ON																																																
2.5 Second Delay	TAKE & WARM LED ON																																																
3.0 Second Delay	SYNC & WARM LED ON																																																
3.5 Second Delay	TAKE, SYNC, & WARM LED ON																																																
4.0 Second Delay	TROLL LED ON																																																
4.5 Second Delay	TAKE & TROLL LED ON																																																
5.0 Second Delay	SYNC & TROLL LED ON																																																
5.5 Second Delay	TAKE, SYNC, & TROLL LED ON																																																
6.0 Second Delay	WARM & TROLL LED ON																																																
6.5 Second Delay	TAKE, WARM, & TROLL LED ON																																																
7.0 Second Delay	SYNC, WARM, & TROLL LED ON																																																
8.0 Second Delay	ALL 4 LEDS ON																																																
	Press & Release WARM button 1 time to save option selection in memory	Once selection has been saved by pressing & releasing the WARM button, you may: <ol style="list-style-type: none"> continue to change other configuration options on the following pages OR . . . you may EXIT CONFIGURATION MODE by turning system OFF, moving control handles back to NEUTRAL, and then turn system ON again. 																																																

7.5.6 High-Idle Step Size (Pt. 1) Options

The High-Idle Step Size (Pt. 1) Option allows you to configure the Smart Actuator II™™ system to increase engine idle speed from .5% to 30% of total throttle output.

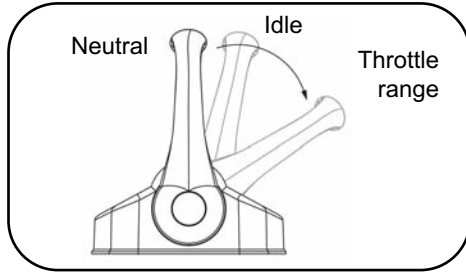

While in Neutral or Idle Detent Control Head handle positions...

Configurable Engine Idle Setting
(see chart below)

(Default = 4% of total throttle output)

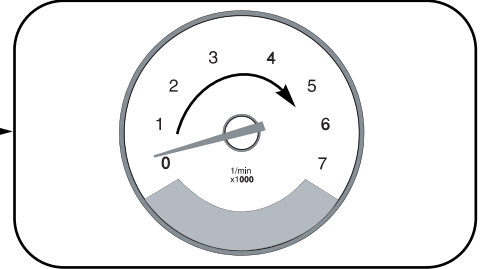

engine idle speed can be increased according to desired setting

To Change High-Idle Step Size Setting Follow These Steps:

Enter Configuration Mode as described in section 7.5 (pg. 73)			
ACTION	RESULT		
<p>Press & Release SYNC button 6 times for High-Idle Step Size, 1</p>	SYNC & WARM LEDs will begin to flash		
<p>Press & Release WARM button 1 time to activate selection</p>	LEDs for current Hi-Idle Step option will be displayed		
<p>Press & Release SYNC button repeatedly to cycle through High Idle Options, LED will illuminate according to selection chosen (see chart at right)</p>			
	1	None	0.5% of Throttle Range
	2	TAKE	1% of Throttle Range
	3	SYNC	2% of Throttle Range
	4	TAKE & SYNC	3% of Throttle Range
	5	WARM	4% of Throttle Range (default)
	6	TAKE & WARM	5% of Throttle Range
	7	SYNC & WARM	10% of Throttle Range
	8	TAKE, SYNC & WARM	20% of Throttle Range
9	TROLL	30% of Throttle Range	
<p>Press & Release WARM button 1 time to save option selection in memory</p>	<p>Once selection has been saved by pressing & releasing the WARM button, you may:</p> <ol style="list-style-type: none"> 1) continue to change other configuration options on the following pages OR . . . 2) you may EXIT CONFIGURATION MODE by turning system OFF, moving control handles back to NEUTRAL, and then turn system ON again. 		

7.5.7 High-Idle Step Size (Pt. 2) Options

The High-Idle Step Size (Pt. 2) Option allows you to configure the Smart Actuator II™™ system to change idle speed beyond the High-Idle Step (Pt. 1) Option range (from .5% to 5%).

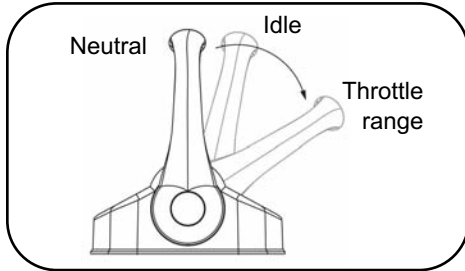

While in Neutral or Idle Detent Control Head handle positions...

Configurable Engine Idle Setting
(see chart below)

(Default = 2% of total throttle output)

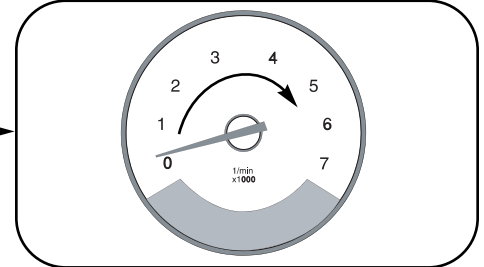

engine idle speed can be increased according to desired setting

To Change High-Idle Step Size Setting Follow These Steps:

Enter Configuration Mode as described in section 7.5 (pg. 73)																								
ACTION		RESULT																						
	Press & Release SYNC button 7 times for High-Idle Step Size, 2	TAKE, SYNC & WARM LEDs will begin to flash																						
	Press & Release WARM button 1 time to activate selection	LEDs for current Hi-Idle Step option will be displayed																						
	Press & Release SYNC button repeatedly to cycle through High Idle Options, LED will illuminate according to selection chosen (see chart at right)	<table border="1"> <thead> <tr> <th></th> <th>LEDs ON</th> <th>AMOUNT OF HIGH-IDLE STEP</th> </tr> </thead> <tbody> <tr> <td>1</td> <td>None</td> <td>0.5% of Throttle Range</td> </tr> <tr> <td>2</td> <td>TAKE</td> <td>1% of Throttle Range</td> </tr> <tr> <td>3</td> <td>SYNC</td> <td>2% of Throttle Range (default)</td> </tr> <tr> <td>4</td> <td>TAKE & SYNC</td> <td>3% of Throttle Range</td> </tr> <tr> <td>5</td> <td>WARM</td> <td>4% of Throttle Range</td> </tr> <tr> <td>6</td> <td>TAKE & WARM</td> <td>5% of Throttle Range</td> </tr> </tbody> </table>		LEDs ON	AMOUNT OF HIGH-IDLE STEP	1	None	0.5% of Throttle Range	2	TAKE	1% of Throttle Range	3	SYNC	2% of Throttle Range (default)	4	TAKE & SYNC	3% of Throttle Range	5	WARM	4% of Throttle Range	6	TAKE & WARM	5% of Throttle Range	
	LEDs ON	AMOUNT OF HIGH-IDLE STEP																						
1	None	0.5% of Throttle Range																						
2	TAKE	1% of Throttle Range																						
3	SYNC	2% of Throttle Range (default)																						
4	TAKE & SYNC	3% of Throttle Range																						
5	WARM	4% of Throttle Range																						
6	TAKE & WARM	5% of Throttle Range																						
	Press & Release WARM button 1 time to save option selection in memory	Once selection has been saved by pressing & releasing the WARM button, you may: 1) continue to change other configuration options on the following pages OR ... 2) you may EXIT CONFIGURATION MODE by turning system OFF, moving control handles back to NEUTRAL, and then turn system ON again.																						

7.5.8 System Startup Options

The System Startup Option allows you to configure the Smart Actuator II™™ system to enter WARM Mode or Normal RUN Mode at startup (power ON).

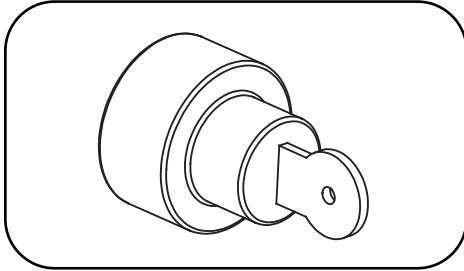

When turning system ON...

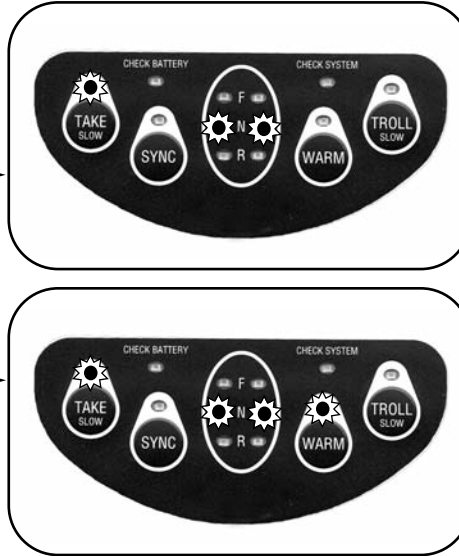

the transmission will immediately respond to the any movement of the control head handles - normal operation

(Default)

OR

the transmission will be locked in WARM Mode (Neutral position) - RPMs will be increased only

To Change System Startup Setting Follow These Steps:

Enter Configuration Mode as described in section 7.5 (pg. 73)					
		ACTION	RESULT		
		Press & Release SYNC button 8 times for System Startup Option	TROLL LED will begin to flash		
		Press & Release WARM button 1 time to activate selection	LEDs for current System Startup option will be displayed		
		Press & Release SYNC button repeatedly to cycle through System Startup Options, LED will illuminate according to selection chosen (see chart at right)	1	LEDs ON	OPTION
				None	WARM Mode (locked in Neutral)
			2	TAKE	Normal RUN Mode (Default)
		Press & Release WARM button 1 time to save option selection in memory	Once selection has been saved by pressing & releasing the WARM button, you may: 1) continue to change other configuration options on the following pages OR . . . 2) you may EXIT CONFIGURATION MODE by turning system OFF, moving control handles back to NEUTRAL, and then turn system ON again.		

7.5.9 Station Transfer Options

The Station Transfer Option allows you to configure the Smart Actuator II™™ system to transfer station control underway above idle or with handles at the Neutral position only.

NOTE: Active Station can be at any handle position during station transfer

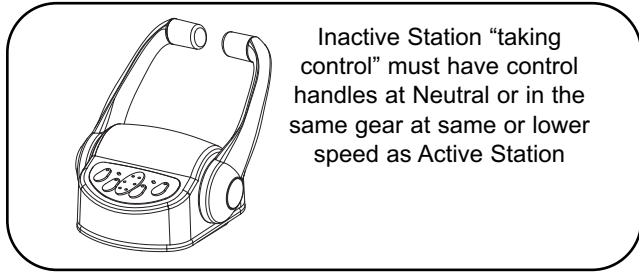

OR

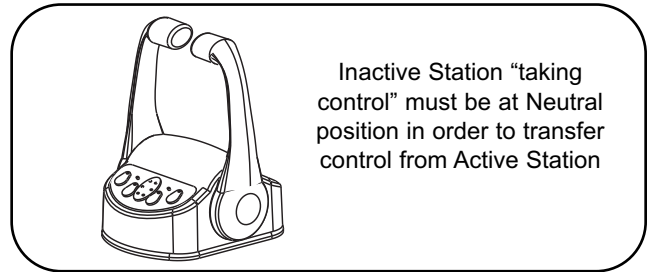

Choose "underway transfer" when you want to transfer control when handles are in appropriate position—not limited to Neutral gear only (Default)

Choose "Neutral transfer" when you want to transfer control when handles are in Neutral only



To Change Station Transfer Setting Follow These Steps:

Enter Configuration Mode as described in section 7.5 (pg. 73)												
		ACTION	RESULT									
		Press & Release SYNC button 9 times for Station Transfer Option	TAKE & TROLL LEDs will begin to flash									
		Press & Release WARM button 1 time to activate selection	LEDs for current Station Transfer option will be displayed									
		Press & Release SYNC button to cycle through Station Transfer Options, LEDs will illuminate (see chart at right)	<table border="1"> <thead> <tr> <th></th> <th style="text-align: center;">LEDs ON</th> <th style="text-align: center;">OPTION</th> </tr> </thead> <tbody> <tr> <td style="text-align: center;">1</td> <td style="text-align: center;">None</td> <td style="text-align: center;">Underway Transfer (Default)</td> </tr> <tr> <td style="text-align: center;">2</td> <td style="text-align: center;">TAKE</td> <td style="text-align: center;">Transfer At Neutral Position only</td> </tr> </tbody> </table>		LEDs ON	OPTION	1	None	Underway Transfer (Default)	2	TAKE	Transfer At Neutral Position only
	LEDs ON	OPTION										
1	None	Underway Transfer (Default)										
2	TAKE	Transfer At Neutral Position only										
		Press & Release WARM button 1 time to save option selection in memory	Once selection has been saved by pressing & releasing the WARM button, you may: <ol style="list-style-type: none"> 1) continue to change other configuration options on the following pages OR . . . 2) you may EXIT CONFIGURATION MODE by turning system OFF, moving control handles back to NEUTRAL, and then turn system ON again. 									

7.5.10 Return System Settings to Default Option

The Return System Settings to Default Option allows you to return the Smart Actuator II™™ system to it's factory default settings.

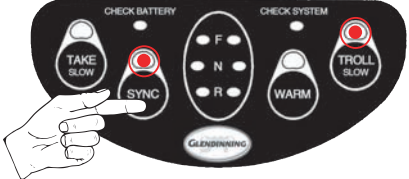
To Change System Settings to the Default values, Follow These Steps:

<i>Enter Configuration Mode as described in section 7.5 (pg. 73)</i>	
ACTION	RESULT
	<p><i>Press & Release SYNC button 10 times for Return to Default Option</i></p> <p><i>SYNC & TROLL LEDs will begin to flash</i></p>
	<p><i>Press & Release WARM button 1 time to save option selection in memory</i></p> <p><i>Once selection has been saved by pressing & releasing the WARM button, you may:</i></p> <ol style="list-style-type: none"> <i>1) continue to change other configuration options on the following pages OR . . .</i> <i>2) you may EXIT CONFIGURATION MODE by turning system OFF, moving control handles back to NEUTRAL, and then turn system ON again.</i>

7.5.11 Sync Gain Options

The Sync Gain Option allows you to configure the Smart Actuator II™ system to allow the Slave engine to respond quicker when you are in SYNC Mode. The higher the Sync Gain number the quicker the response.

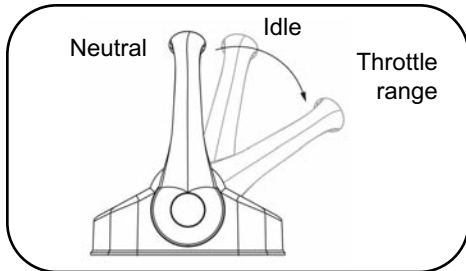

While in SYNC Mode moving the control head handles...

Configurable Sync Gain Setting
(see chart below)

(Default = Sync Gain setting #12)

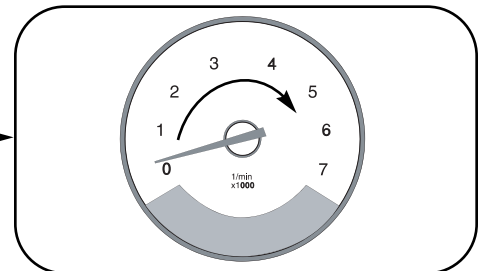

causes the SLAVE engine (normally PORT) to respond quicker to the movement of the control head handles

To Change Sync Gain Setting Follow These Steps:

<i>Enter Configuration Mode as described in section 7.5 (pg. 73)</i>																																															
	ACTION	RESULT																																													
	Press & Release SYNC button 11 times for Sync Gain Options	TAKE, SYNC & TROLL LEDs will begin to flash																																													
	Press & Release WARM button 1 time to activate selection	LEDs for current Sync Gain option will be displayed																																													
	Press & Release SYNC button repeatedly to cycle through Sync Gain Options, LED will illuminate according to selection chosen (see chart at right)	<table border="0" style="width: 100%;"> <tr><td>Sync Gain #1</td><td>.....</td><td>TAKE LED ON</td></tr> <tr><td>Sync Gain #2</td><td>.....</td><td>SYNC LED ON</td></tr> <tr><td>Sync Gain #3</td><td>.....</td><td>TAKE & SYNC LED ON</td></tr> <tr><td>Sync Gain #4</td><td>.....</td><td>WARM LED ON</td></tr> <tr><td>Sync Gain #5</td><td>.....</td><td>TAKE & WARM LED ON</td></tr> <tr><td>Sync Gain #6</td><td>.....</td><td>SYNC & WARM LED ON</td></tr> <tr><td>Sync Gain #7</td><td>.....</td><td>TAKE, SYNC, & WARM LED ON</td></tr> <tr><td>Sync Gain #8</td><td>.....</td><td>TROLL LED ON</td></tr> <tr><td>Sync Gain #9</td><td>.....</td><td>TAKE & TROLL LED ON</td></tr> <tr><td>Sync Gain #10</td><td>.....</td><td>SYNC & TROLL LED ON</td></tr> <tr><td>Sync Gain #11</td><td>.....</td><td>TAKE, SYNC, & TROLL LED ON</td></tr> <tr><td>Sync Gain #12(Default)</td><td>.....</td><td>WARM & TROLL LED ON</td></tr> <tr><td>Sync Gain #13</td><td>.....</td><td>TAKE, WARM, & TROLL LED ON</td></tr> <tr><td>Sync Gain #14</td><td>.....</td><td>SYNC, WARM, & TROLL LED ON</td></tr> <tr><td>Sync Gain #15</td><td>.....</td><td>ALL 4 LEDS ON</td></tr> </table>	Sync Gain #1	TAKE LED ON	Sync Gain #2	SYNC LED ON	Sync Gain #3	TAKE & SYNC LED ON	Sync Gain #4	WARM LED ON	Sync Gain #5	TAKE & WARM LED ON	Sync Gain #6	SYNC & WARM LED ON	Sync Gain #7	TAKE, SYNC, & WARM LED ON	Sync Gain #8	TROLL LED ON	Sync Gain #9	TAKE & TROLL LED ON	Sync Gain #10	SYNC & TROLL LED ON	Sync Gain #11	TAKE, SYNC, & TROLL LED ON	Sync Gain #12(Default)	WARM & TROLL LED ON	Sync Gain #13	TAKE, WARM, & TROLL LED ON	Sync Gain #14	SYNC, WARM, & TROLL LED ON	Sync Gain #15	ALL 4 LEDS ON
Sync Gain #1	TAKE LED ON																																													
Sync Gain #2	SYNC LED ON																																													
Sync Gain #3	TAKE & SYNC LED ON																																													
Sync Gain #4	WARM LED ON																																													
Sync Gain #5	TAKE & WARM LED ON																																													
Sync Gain #6	SYNC & WARM LED ON																																													
Sync Gain #7	TAKE, SYNC, & WARM LED ON																																													
Sync Gain #8	TROLL LED ON																																													
Sync Gain #9	TAKE & TROLL LED ON																																													
Sync Gain #10	SYNC & TROLL LED ON																																													
Sync Gain #11	TAKE, SYNC, & TROLL LED ON																																													
Sync Gain #12(Default)	WARM & TROLL LED ON																																													
Sync Gain #13	TAKE, WARM, & TROLL LED ON																																													
Sync Gain #14	SYNC, WARM, & TROLL LED ON																																													
Sync Gain #15	ALL 4 LEDS ON																																													
	Press & Release WARM button 1 time to save option selection in memory	<p>Once selection has been saved by pressing & releasing the WARM button, you may:</p> <ol style="list-style-type: none"> 1) continue to change other configuration options on the following pages OR . . . 2) you may EXIT CONFIGURATION MODE by turning system OFF, moving control handles back to NEUTRAL, and then turn system ON again. 																																													

7.5.13 Neutral Delay Options

The Neutral Delay Option allows you to configure the Smart Actuator II™ system to pause in Neutral when the system goes from the throttle range (above idle) to the opposing throttle range, to allow the transmission to reach Neutral before shifting into the other gear.

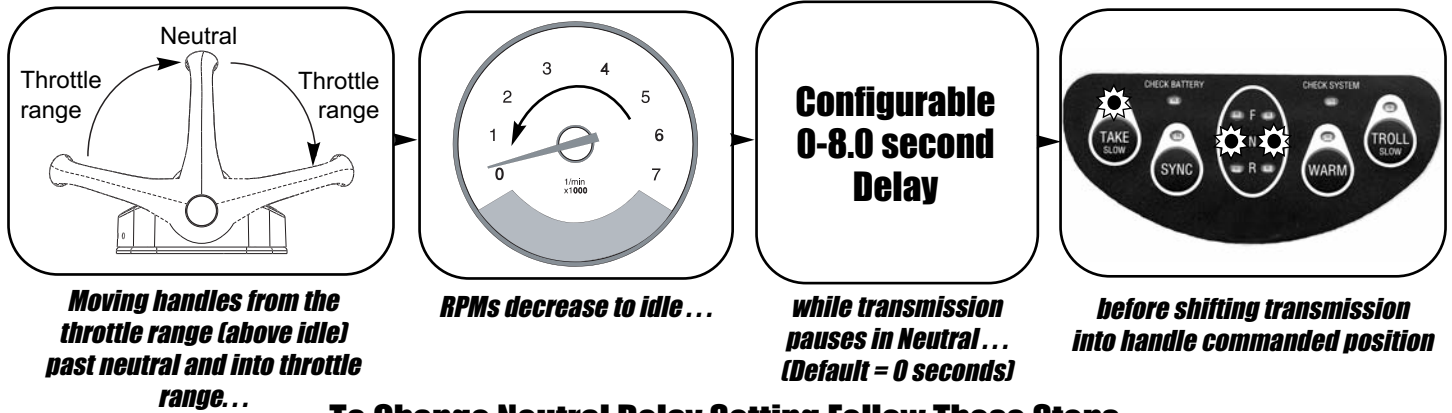

To Change Neutral Delay Setting Follow These Steps:

Enter Configuration Mode as described in section 7.5 (pg. 73)																																																		
ACTION	RESULT																																																	
	<p>Press & Release SYNC button 13 times for Neutral Delay Option</p>	<p>TAKE, WARM, & TROLL LEDs will begin to flash</p>																																																
	<p>Press & Release WARM button 1 time to activate selection</p>	<p>LEDs for current Neutral Delay option will be displayed</p>																																																
	<p>Press & Release SYNC button repeatedly to cycle through Neutral Delay Options, LED will illuminate according to selection chosen (see chart at right)</p>	<table border="0"> <tr> <td>NO delay (default)</td> <td>.....</td> <td>TAKE LED ON</td> </tr> <tr> <td>0.5 Second Delay</td> <td>.....</td> <td>TAKE LED ON</td> </tr> <tr> <td>1.0 Second Delay</td> <td>.....</td> <td>SYNC LED ON</td> </tr> <tr> <td>1.5 Second Delay</td> <td>.....</td> <td>TAKE & SYNC LED ON</td> </tr> <tr> <td>2.0 Second Delay</td> <td>.....</td> <td>WARM LED ON</td> </tr> <tr> <td>2.5 Second Delay</td> <td>.....</td> <td>TAKE & WARM LED ON</td> </tr> <tr> <td>3.0 Second Delay</td> <td>.....</td> <td>SYNC & WARM LED ON</td> </tr> <tr> <td>3.5 Second Delay</td> <td>.....</td> <td>TAKE, SYNC, & WARM LED ON</td> </tr> <tr> <td>4.0 Second Delay</td> <td>.....</td> <td>TROLL LED ON</td> </tr> <tr> <td>4.5 Second Delay</td> <td>.....</td> <td>TAKE & TROLL LED ON</td> </tr> <tr> <td>5.0 Second Delay</td> <td>.....</td> <td>SYNC & TROLL LED ON</td> </tr> <tr> <td>5.5 Second Delay</td> <td>.....</td> <td>TAKE, SYNC, & TROLL LED ON</td> </tr> <tr> <td>6.0 Second Delay</td> <td>.....</td> <td>WARM & TROLL LED ON</td> </tr> <tr> <td>6.5 Second Delay</td> <td>.....</td> <td>TAKE, WARM, & TROLL LED ON</td> </tr> <tr> <td>7.0 Second Delay</td> <td>.....</td> <td>SYNC, WARM, & TROLL LED ON</td> </tr> <tr> <td>8.0 Second Delay</td> <td>.....</td> <td>ALL 4 LEDS ON</td> </tr> </table>	NO delay (default)	TAKE LED ON	0.5 Second Delay	TAKE LED ON	1.0 Second Delay	SYNC LED ON	1.5 Second Delay	TAKE & SYNC LED ON	2.0 Second Delay	WARM LED ON	2.5 Second Delay	TAKE & WARM LED ON	3.0 Second Delay	SYNC & WARM LED ON	3.5 Second Delay	TAKE, SYNC, & WARM LED ON	4.0 Second Delay	TROLL LED ON	4.5 Second Delay	TAKE & TROLL LED ON	5.0 Second Delay	SYNC & TROLL LED ON	5.5 Second Delay	TAKE, SYNC, & TROLL LED ON	6.0 Second Delay	WARM & TROLL LED ON	6.5 Second Delay	TAKE, WARM, & TROLL LED ON	7.0 Second Delay	SYNC, WARM, & TROLL LED ON	8.0 Second Delay	ALL 4 LEDS ON
NO delay (default)	TAKE LED ON																																																
0.5 Second Delay	TAKE LED ON																																																
1.0 Second Delay	SYNC LED ON																																																
1.5 Second Delay	TAKE & SYNC LED ON																																																
2.0 Second Delay	WARM LED ON																																																
2.5 Second Delay	TAKE & WARM LED ON																																																
3.0 Second Delay	SYNC & WARM LED ON																																																
3.5 Second Delay	TAKE, SYNC, & WARM LED ON																																																
4.0 Second Delay	TROLL LED ON																																																
4.5 Second Delay	TAKE & TROLL LED ON																																																
5.0 Second Delay	SYNC & TROLL LED ON																																																
5.5 Second Delay	TAKE, SYNC, & TROLL LED ON																																																
6.0 Second Delay	WARM & TROLL LED ON																																																
6.5 Second Delay	TAKE, WARM, & TROLL LED ON																																																
7.0 Second Delay	SYNC, WARM, & TROLL LED ON																																																
8.0 Second Delay	ALL 4 LEDS ON																																																
	<p>Press & Release WARM button 1 time to save option selection in memory</p>	<p>Once selection has been saved by pressing & releasing the WARM button, you may:</p> <ol style="list-style-type: none"> 1) continue to change other configuration options on the following pages OR . . . 2) you may EXIT CONFIGURATION MODE by turning system OFF, moving control handles back to NEUTRAL, and then turn system ON again. 																																																

7.5.15 Throttle Bump Options

The Throttle Bump Option allows you to configure the Smart Actuator II™™ system to increase throttle outputs in small increments from 1% to 9% of full travel range.

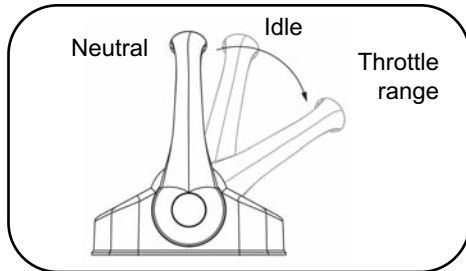

While Control handles are in the throttle range (past Idle detent)...

Configurable Throttle Bump Setting
(see chart below)

Throttle Bump Setting will determine the amount of increase or decrease for each "bump" (Default = 1% of Full Travel Range)

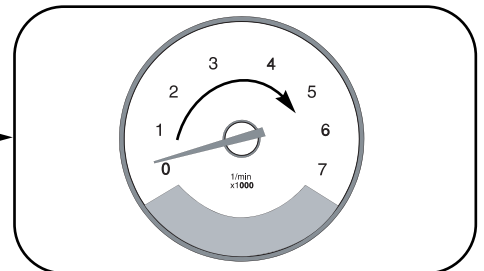

when the Throttle Bump feature in engaged

To Change Throttle Bump Setting Follow These Steps:

<i>Enter Configuration Mode as described in section 7.5 (pg. 73)</i>																																
ACTION	RESULT																															
	<p>Press & Release SYNC button 15 times for Throttle Bump Amount</p> <p style="text-align: center;">TAKE, SYNC, WARM & TROLL LEDs will begin to flash</p>																															
	<p>Press & Release WARM button 1 time to activate selection</p> <p style="text-align: center;">LEDs for current Throttle Bump option will be displayed</p>																															
	<p>Press & Release SYNC button repeatedly to cycle through Throttle Bump Options, LED will illuminate according to selection chosen (see chart at right)</p>	<table border="1" style="width: 100%; text-align: center;"> <thead> <tr> <th style="width: 5%;">#</th> <th style="width: 40%;">LEDs ON</th> <th style="width: 55%;">AMOUNT OF THROTTLE BUMP</th> </tr> </thead> <tbody> <tr> <td>1</td> <td>None</td> <td>1% of Full Travel Range (default)</td> </tr> <tr> <td>2</td> <td>TAKE</td> <td>2% of Full Travel Range</td> </tr> <tr> <td>3</td> <td>SYNC</td> <td>3% of Full Travel Range</td> </tr> <tr> <td>4</td> <td>TAKE & SYNC</td> <td>4% of Full Travel Range</td> </tr> <tr> <td>5</td> <td>WARM</td> <td>5% of Full Travel Range</td> </tr> <tr> <td>6</td> <td>TAKE & WARM</td> <td>6% of Full Travel Range</td> </tr> <tr> <td>7</td> <td>SYNC & WARM</td> <td>7% of Full Travel Range</td> </tr> <tr> <td>8</td> <td>TAKE, SYNC & WARM</td> <td>8% of Full Travel Range</td> </tr> <tr> <td>9</td> <td>TROLL</td> <td>9% of Full Travel Range</td> </tr> </tbody> </table>	#	LEDs ON	AMOUNT OF THROTTLE BUMP	1	None	1% of Full Travel Range (default)	2	TAKE	2% of Full Travel Range	3	SYNC	3% of Full Travel Range	4	TAKE & SYNC	4% of Full Travel Range	5	WARM	5% of Full Travel Range	6	TAKE & WARM	6% of Full Travel Range	7	SYNC & WARM	7% of Full Travel Range	8	TAKE, SYNC & WARM	8% of Full Travel Range	9	TROLL	9% of Full Travel Range
#	LEDs ON	AMOUNT OF THROTTLE BUMP																														
1	None	1% of Full Travel Range (default)																														
2	TAKE	2% of Full Travel Range																														
3	SYNC	3% of Full Travel Range																														
4	TAKE & SYNC	4% of Full Travel Range																														
5	WARM	5% of Full Travel Range																														
6	TAKE & WARM	6% of Full Travel Range																														
7	SYNC & WARM	7% of Full Travel Range																														
8	TAKE, SYNC & WARM	8% of Full Travel Range																														
9	TROLL	9% of Full Travel Range																														
	<p>Press & Release WARM button 1 time to save option selection in memory</p>	<p>Once selection has been saved by pressing & releasing the WARM button, you may:</p> <ol style="list-style-type: none"> 1) continue to change other configuration options on the following pages OR . . . 2) you may EXIT CONFIGURATION MODE by turning system OFF, moving control handles back to NEUTRAL, and then turn system ON again. 																														

7.5.16 Selectable Sync Master Options

The Sync Master Select Option allows you to determine which handle will be used as the sync master. This function will allow the user to change the default setting which will enable the PORT handle to be used as the master engine.

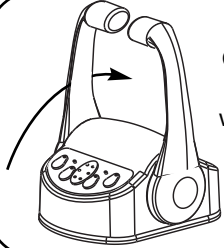

Choose "PORT is MASTER" if during engine synchronization you want the STBD engine to follow the position of the PORT handle movement.

OR

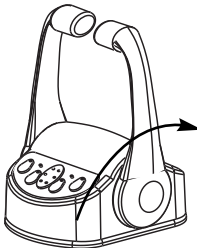

Choose "STBD is MASTER" if during engine synchronization you want the PORT engine to follow the position of the STBD handle movement (Default).

To Change Selectable Sync Master Setting Follow These Steps:

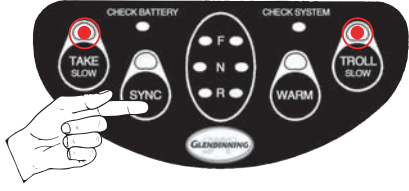
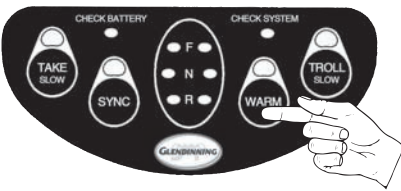
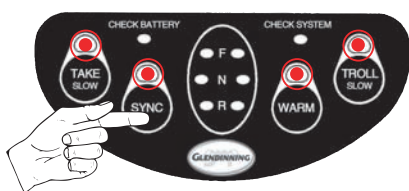
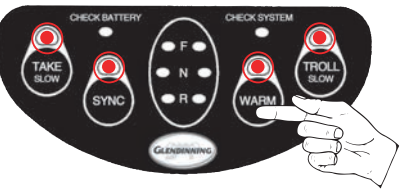
		Enter Configuration Mode as described in section 7.5 (pg. 73)		
		ACTION	RESULT	
	<p>Press & Release SYNC button 16 times for Selectable Sync Master Options</p>	<p>TAKE LEDs will begin to QUICK flash</p>		
	<p>Press & Release WARM button 1 time to activate selection</p>	<p>LEDs for current Sync Master option will be displayed</p>		
	<p>Press & Release SYNC button to cycle through Selectable Sync Master Options, LEDs will illuminate (see chart at right)</p>	<p>1</p>	<p>LEDs ON</p>	<p>SYNC MASTER OPTION</p>
			<p>2</p>	<p>TAKE</p>
	<p>Press & Release WARM button 1 time to save option selection in memory</p>	<p>Once selection has been saved by pressing & releasing the WARM button, you may:</p> <ol style="list-style-type: none"> 1) continue to change other configuration options on the following pages OR . . . 2) you may EXIT CONFIGURATION MODE by turning system OFF, moving control handles back to NEUTRAL, and then turn system ON again. 		

7.5.17 Throttle Curve Select Options

The Throttle Curve Option allows for engines that accelerate quickly in the low or high end with little handle movement to be made less sensitive. A throttle curve will map the actuator movement to a smaller one with a larger handle movement. See the graphic depiction for each throttle curve on the next page.

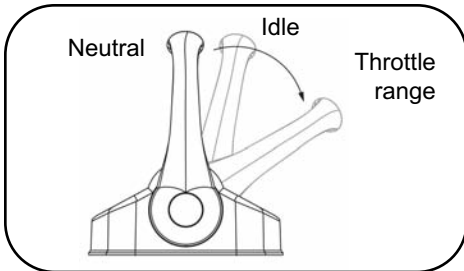

While moving control handles past the idle detent and into the throttle range . . .

Configurable Throttle Curve Setting
(see chart below)

Throttle Curve selected causes appropriate engine response (Default = NO Throttle Curve) . . .

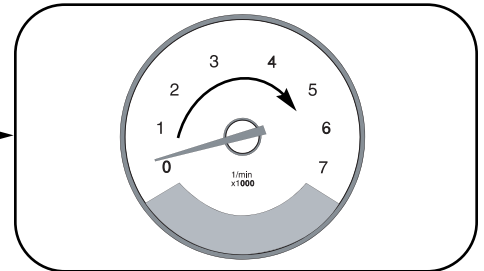

which allows the engine to respond more accurately to the control handle position

To Change Throttle Curve Setting Follow These Steps:

Enter Configuration Mode as described in section 7.5 (pg. 73)		
ACTION	RESULT	
	SYNC, WARM & TROLL LEDs will begin to flash	
	LEDs for current Throttle Curve option will be displayed	
		AMOUNT OF THROTTLE CURVE
	1	None
	2	TAKE
	3	SYNC
	4	TAKE & SYNC
	5	WARM
	6	TAKE & WARM
	7	SYNC & WARM
8	TAKE, SYNC & WARM	
	Once selection has been saved by pressing & releasing the WARM button, you may: 1) continue to change other configuration options on the following pages OR . . . 2) you may EXIT CONFIGURATION MODE by turning system OFF, moving control handles back to NEUTRAL, and then turn system ON again.	

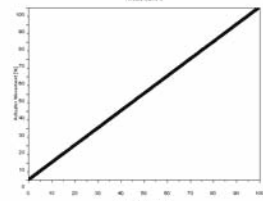
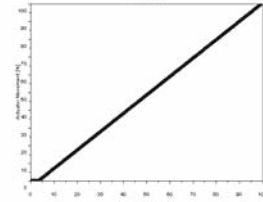
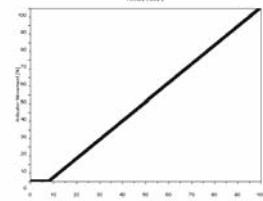
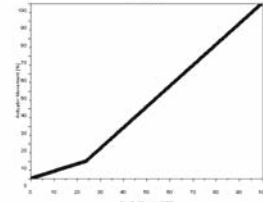
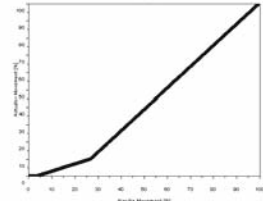
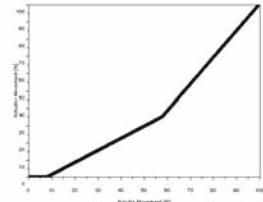
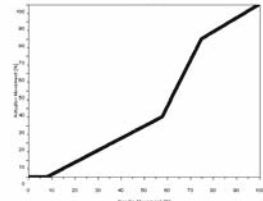
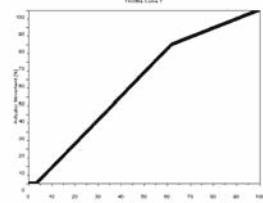
THROTTLE CURVE	HANDLE MOVEMENT	ENGINE SPEED RESPONSE
<p>0</p> 	<p>0-100%</p>	<p>0-100% (linear)</p>
<p>1</p> 	<p>0-3.5%</p>	<p>No speed change (IDLE)</p>
	<p>3.5-100%</p>	<p>0-100%</p>
<p>2</p> 	<p>0-8%</p>	<p>No speed change (IDLE)</p>
	<p>8-100%</p>	<p>0-100%</p>
<p>3</p> 	<p>0-24%</p>	<p>0-10%</p>
	<p>24-100%</p>	<p>10-100%</p>
<p>4</p> 	<p>0-3.5%</p>	<p>No speed change (IDLE)</p>
	<p>3.5-27%</p>	<p>0-10%</p>
	<p>27-100%</p>	<p>10-100%</p>
<p>5</p> 	<p>0-8%</p>	<p>No speed change (IDLE)</p>
	<p>8-58%</p>	<p>0-35%</p>
	<p>58-100%</p>	<p>35-100%</p>
<p>6</p> 	<p>0-8%</p>	<p>No speed change (IDLE)</p>
	<p>8-58%</p>	<p>0-35%</p>
	<p>58-75%</p>	<p>35-80%</p>
	<p>75-100%</p>	<p>80-100%</p>
<p>7</p> 	<p>0-3.5%</p>	<p>No speed change (IDLE)</p>
	<p>3.5-62%</p>	<p>0-80%</p>
	<p>62-100%</p>	<p>80-100%</p>

7.5.18 Maximum Dynamic Gear Delay Options

The Dynamic Gear Delay Option allows you to remain in gear for an amount of time when the system goes from the throttle range to neutral. The amount of time the gear shift delays depends on the throttle commanded level and how long you were at that level. The total gear delay is the sum of the dynamic gear delay and the fixed gear delay (see Sec. 7.5.5).

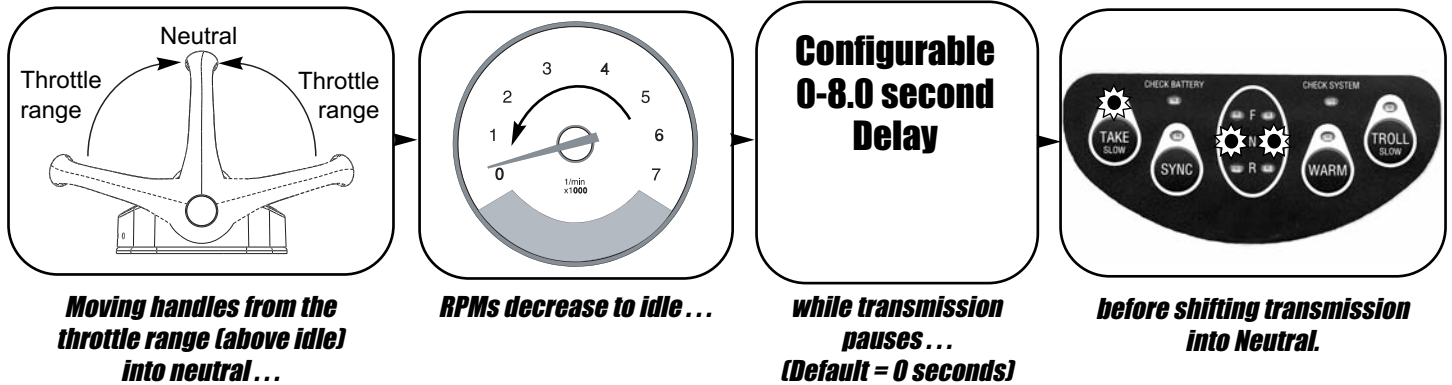

To Change Gear Delay Setting Follow These Steps:

Enter Configuration Mode as described in section 7.5 (pg. 73)																																																		
ACTION	RESULT																																																	
	Press & Release SYNC button 5 times for Gear Delay Option	TAKE & SYNC LEDs will begin to QUICK flash																																																
	Press & Release WARM button 1 time to activate selection	LEDs for current Dynamic Gear Delay option will be displayed																																																
	Press & Release SYNC button repeatedly to cycle through Gear Delay Options, LED will illuminate according to selection chosen (see chart at right)	<table border="0"> <tr><td>NO delay (default)</td><td>.....</td><td>TAKE LED ON</td></tr> <tr><td>0.5 Second Delay</td><td>.....</td><td>TAKE LED ON</td></tr> <tr><td>1.0 Second Delay</td><td>.....</td><td>SYNC LED ON</td></tr> <tr><td>1.5 Second Delay</td><td>.....</td><td>TAKE & SYNC LED ON</td></tr> <tr><td>2.0 Second Delay</td><td>.....</td><td>WARM LED ON</td></tr> <tr><td>2.5 Second Delay</td><td>.....</td><td>TAKE & WARM LED ON</td></tr> <tr><td>3.0 Second Delay</td><td>.....</td><td>SYNC & WARM LED ON</td></tr> <tr><td>3.5 Second Delay</td><td>.....</td><td>TAKE, SYNC, & WARM LED ON</td></tr> <tr><td>4.0 Second Delay</td><td>.....</td><td>TROLL LED ON</td></tr> <tr><td>4.5 Second Delay</td><td>.....</td><td>TAKE & TROLL LED ON</td></tr> <tr><td>5.0 Second Delay</td><td>.....</td><td>SYNC & TROLL LED ON</td></tr> <tr><td>5.5 Second Delay</td><td>.....</td><td>TAKE, SYNC, & TROLL LED ON</td></tr> <tr><td>6.0 Second Delay</td><td>.....</td><td>WARM & TROLL LED ON</td></tr> <tr><td>6.5 Second Delay</td><td>.....</td><td>TAKE, WARM, & TROLL LED ON</td></tr> <tr><td>7.0 Second Delay</td><td>.....</td><td>SYNC, WARM, & TROLL LED ON</td></tr> <tr><td>8.0 Second Delay</td><td>.....</td><td>ALL 4 LEDS ON</td></tr> </table>	NO delay (default)	TAKE LED ON	0.5 Second Delay	TAKE LED ON	1.0 Second Delay	SYNC LED ON	1.5 Second Delay	TAKE & SYNC LED ON	2.0 Second Delay	WARM LED ON	2.5 Second Delay	TAKE & WARM LED ON	3.0 Second Delay	SYNC & WARM LED ON	3.5 Second Delay	TAKE, SYNC, & WARM LED ON	4.0 Second Delay	TROLL LED ON	4.5 Second Delay	TAKE & TROLL LED ON	5.0 Second Delay	SYNC & TROLL LED ON	5.5 Second Delay	TAKE, SYNC, & TROLL LED ON	6.0 Second Delay	WARM & TROLL LED ON	6.5 Second Delay	TAKE, WARM, & TROLL LED ON	7.0 Second Delay	SYNC, WARM, & TROLL LED ON	8.0 Second Delay	ALL 4 LEDS ON
NO delay (default)	TAKE LED ON																																																
0.5 Second Delay	TAKE LED ON																																																
1.0 Second Delay	SYNC LED ON																																																
1.5 Second Delay	TAKE & SYNC LED ON																																																
2.0 Second Delay	WARM LED ON																																																
2.5 Second Delay	TAKE & WARM LED ON																																																
3.0 Second Delay	SYNC & WARM LED ON																																																
3.5 Second Delay	TAKE, SYNC, & WARM LED ON																																																
4.0 Second Delay	TROLL LED ON																																																
4.5 Second Delay	TAKE & TROLL LED ON																																																
5.0 Second Delay	SYNC & TROLL LED ON																																																
5.5 Second Delay	TAKE, SYNC, & TROLL LED ON																																																
6.0 Second Delay	WARM & TROLL LED ON																																																
6.5 Second Delay	TAKE, WARM, & TROLL LED ON																																																
7.0 Second Delay	SYNC, WARM, & TROLL LED ON																																																
8.0 Second Delay	ALL 4 LEDS ON																																																
	Press & Release WARM button 1 time to save option selection in memory	Once selection has been saved by pressing & releasing the WARM button, you may: 1) continue to change other configuration options on the following pages OR ... 2) you may EXIT CONFIGURATION MODE by turning system OFF, moving control handles back to NEUTRAL, and then turn system ON again.																																																

7.6 Actuator Functional Configuration

IF YOU PURCHASED A COMPLETE SYSTEM, ACTUATOR FUNCTIONAL CONFIGURATION WAS PERFORMED AT THE FACTORY. ALL THAT IS NEEDED BY THE INSTALLER IS TO CALIBRATE THE ACTUATOR ENDPOINTS AND CABLE DIRECTION — SEE SECTION 4.0.

If you purchased an Actuator separately, you may need to configure the Smart Actuator II™ by following the procedures below to achieve the desired configuration for your system. The configuration of the Smart Actuator II™ is divided into five sections. Two of the sections, setting actuator cable direction for actuators 1 and 2 have been discussed in detail in Section 4.0. In this section we will discuss the remaining 3, which are:

- Setting the Actuator Default Configuration
- Setting the Actuator Identifier
- Setting the Tachometer Pulses / Revolution (PPR)

In order to enter the configuration mode you must follow the steps below:

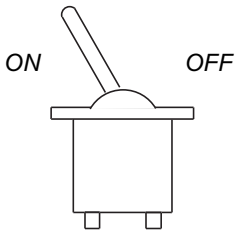
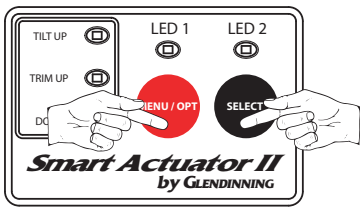
	<p>ACTION</p> <p>Turn power to Smart Actuator II™s ON</p>	<p>RESULT</p> <p>N/A</p>
	<p>Press & Release in sequence the RED then the BLACK then the RED buttons on the Smart Actuator (you have 5 seconds to complete process)</p>	<p>Both LEDs above the RED and BLACK buttons will flash to indicate that you have entered Smart Actuator II™ Configuration Menu (if the System does NOT enter configuration mode, wait at least 5 seconds and repeat the process)</p>

Once BOTH LEDs are flashing you are ready to proceed by selecting which configuration menu you would like to change. After changing each selection it will be necessary to store that selection in memory (detailed in each section). After storing the selections you have made the system will return to this state — BOTH LEDs flashing — to allow other menus to be selected. This will enable you to make configuration changes without having to leave the configuration mode each time a change is made to a menu.

7.6.1 — Setting the Actuator Default Configuration:

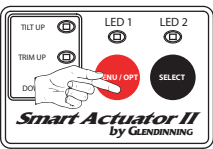
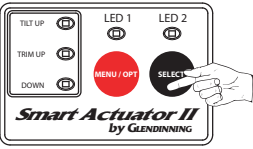
<p>1</p> 	<p>ACTION</p> <p>Press & Release the RED button on the Smart Actuator 3 times to select Actuator Default Configuration Menu</p>	<p>RESULT</p> <p>The RED LED will begin to flash 3 times, pause and then repeat.</p>
<p>2</p> 	<p>Press & Release the BLACK button 1 time to store the Actuator Default Settings</p>	<p>This action will return you to the main configuration menu indicated by BOTH LEDs flashing. You may continue to the setting of Actuator Identifier Menu OR you may EXIT Configuration Mode by turning power OFF,</p>

7.6.2 — Setting the Actuator Identifier:

Setting the Actuator Identifier is necessary to enable the Smart Actuator II™ to “talk” to the CANbus network.

IF YOU PURCHASED A COMPLETE SYSTEM, THE ACTUATOR IDENTIFIER WAS PERFORMED AT THE FACTORY. ALL THAT IS NEEDED BY THE INSTALLER IS TO CALIBRATE THE ACTUATOR ENDPOINTS AND CABLE DIRECTION. If you purchased an Actuator separately, you may need to set the Actuator identifier (see instructions below) for that Actuator as well as perform calibration for the endpoints and cable direction (see Section 4.0).

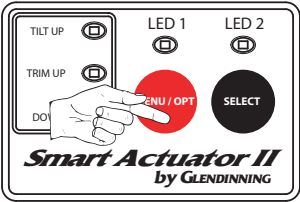
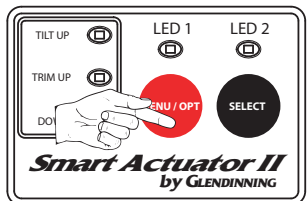
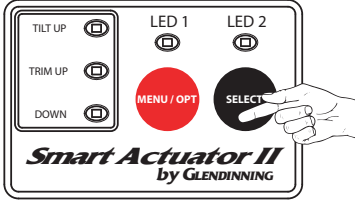
<p>1</p> 	<p>ACTION</p> <p>Press & Release the RED button on the Smart Actuator 4 times</p>	<p>RESULT</p> <p>The LED above the RED button will begin to flash 4 times, pause then repeat</p>																							
<p>2</p> 	<p>Press & Release the BLACK button to select Actuator Identifier Configuration</p>	<p>The RED LED will continue to flash to indicate which menu you are currently in The BLACK LED will indicate the available selections within this menu.</p>																							
<p>3</p> 	<p>ACTION</p> <p>Press & Release the RED button on the Smart Actuator until the desired Actuator Identifier is achieved (indicated by BLACK LED)</p>	<p>RESULT</p> <table border="1"> <thead> <tr> <th>ID#</th> <th>LEDs ON</th> <th>ACTUATOR DESCRIPTION</th> </tr> </thead> <tbody> <tr> <td>1</td> <td>BLACK FLASHES 1 TIME</td> <td>PORT Throttle/Gear</td> </tr> <tr> <td>2</td> <td>BLACK FLASHES 2 TIMES</td> <td>STBD Throttle/Gear</td> </tr> <tr> <td>3</td> <td>BLACK FLASHES 3 TIMES</td> <td>PORT/STBD Troll</td> </tr> <tr> <td>4</td> <td>BLACK FLASHES 4 TIMES</td> <td>PORT/STBD Throttle w/ solenoid shift</td> </tr> <tr> <td>5</td> <td>BLACK FLASHES 5 TIMES</td> <td>PORT / STBD Gear</td> </tr> <tr> <td>6</td> <td>BLACK FLASHES 6 TIMES</td> <td>CENTER Throttle / Gear</td> </tr> </tbody> </table>			ID#	LEDs ON	ACTUATOR DESCRIPTION	1	BLACK FLASHES 1 TIME	PORT Throttle/Gear	2	BLACK FLASHES 2 TIMES	STBD Throttle/Gear	3	BLACK FLASHES 3 TIMES	PORT/STBD Troll	4	BLACK FLASHES 4 TIMES	PORT/STBD Throttle w/ solenoid shift	5	BLACK FLASHES 5 TIMES	PORT / STBD Gear	6	BLACK FLASHES 6 TIMES	CENTER Throttle / Gear
ID#	LEDs ON	ACTUATOR DESCRIPTION																							
1	BLACK FLASHES 1 TIME	PORT Throttle/Gear																							
2	BLACK FLASHES 2 TIMES	STBD Throttle/Gear																							
3	BLACK FLASHES 3 TIMES	PORT/STBD Troll																							
4	BLACK FLASHES 4 TIMES	PORT/STBD Throttle w/ solenoid shift																							
5	BLACK FLASHES 5 TIMES	PORT / STBD Gear																							
6	BLACK FLASHES 6 TIMES	CENTER Throttle / Gear																							
<p>4</p> 	<p>Press & Release the BLACK button to store actuator identifier in memory</p>	<p>This action will return you to the main configuration menu indicated by BOTH LEDs flashing.</p> <p>Once identifier is stored in memory you may:</p> <ol style="list-style-type: none"> 1) continue to configure the setting of the Tachometer Pulses/Revolution (PPR) OR . . . 2) you may EXIT CONFIGURATION MODE by turning Power OFF. 																							

7.6.3 — Setting the Tachometer Pulses / Revolution (PPR):

Engine RPM tachometer sensors are used in mechanical throttle applications to give a better engine RPM matching control while using the sync feature. When in Sync mode, the Smart Actuator II™ uses the rpm information feedback from the tachometer sending units to keep the slave engine rpm matched with the master engine rpm. In order for the sync function to work properly, the system has to know what type of tachometer sender it is attached to. A tachometer sending unit (external to the Smart Actuator II™) is a device that converts engine RPM to a voltage sine wave signal. The senders usually come in two types, 4 pulses per 1 engine RPM or 6 pulses per 1 engine RPM.

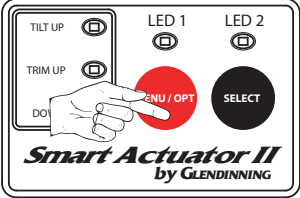
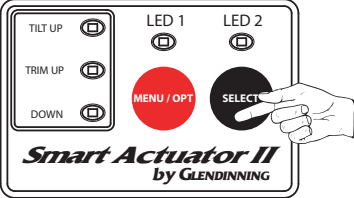
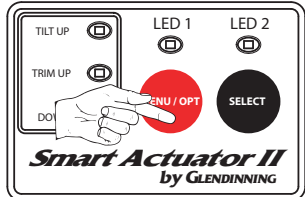
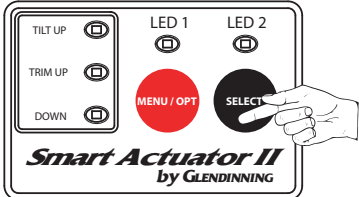
1 	ACTION		RESULT	
	Press & Release the RED button on the Smart Actuator 5 times		The LED above the RED button will begin to flash 5 times, pause then repeat	
2 	Press & Release the BLACK button to select Tachometer Pulses / Revolution Configuration		The RED LED will continue to flash to indicate which menu you are currently in The BLACK LED will indicate the available selections within this menu.	
	3 	ACTION	RESULT	
Press & Release the RED button on the Smart Actuator until the desired Tachometer PPR is achieved (indicated by BLACK LED)		ID#	LEDs ON	SELECTION DESCRIPTION
		1	BLACK FLASHES 1 TIME	4 PPR — generally used with Aetna Tachometer sender units using 1/2 engine speed drive adapters
2	BLACK FLASHES 2 TIMES	6 PPR — generally used with outboards generating a 6 pulse per revolution tachmeter signal (Yamaha, Evinrude, etc.)		
4 	Press & Release the BLACK button to store Tachometer PPR in memory		This action will return you to the main configuration menu indicated by BOTH LEDs flashing. Once Tachometer PPR is stored in memory you may EXIT CONFIGURATION MODE by turning Power OFF.	

7.6.4 To Set Cable Direction for Actuator's LEVER 1, follow these steps:

It may become necessary to change the cable travel direction after calibration has been completed. If so, verify that you are changing the cable direction for the appropriate Actuator function by locating the Serial Number label located on the front (or top) of the Actuator. The ID number signifies that the Actuator has been set up for a particular propulsion arrangement. Actuator's LEVER 1 function depends on the Actuator ID switch setting (see below):

- ACT ID#1 or #2 — Throttle lever on a throttle/gear Actuator
- ACT ID#3 — PORT Troll lever on a troll/troll Actuator
- ACT ID#4 — PORT Throttle lever on a throttle/throttle Actuator
- ACT ID#5 — PORT Gear lever on a gear/gear Actuator

To set the LEVER 1 of the **Actuator's** Cable Direction, follow the steps below:

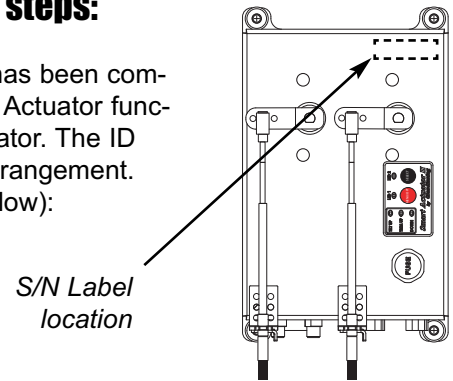

1		ACTION		RESULT	
		Turn power to Smart Actuator II™ ON		N/A	
2		Press & Release in sequence the RED then the BLACK then the RED buttons on the Smart Actuator (you have 5 seconds to complete process)		Both LEDs above the RED and BLACK buttons will flash to indicate that you have entered Smart Actuator II™ Configuration Mode	
3		Press & Release the RED button on the Smart Actuator 1 time to select LEVER 1 Cable Direction Menu		RED LED will flash one time, pause and then repeat	
4		Press & Release the BLACK button 1 time to select LEVER 1 cable direction configuration		The RED LED will continue to flash to show you what menu you are in. The BLACK LED will illuminate to indicate which selection you have chosen below.	
5		Press & Release the RED button until the desired Actuator cable direction is indicated by the LEDs (see chart at right)		LED 2 (BLACK)	TRAVEL DIRECTION
				FLASHED 1 TIME	PUSH direction
				FLASHES 2 TIMES	PULL direction
6		When the desired cable direction is displayed on the LEDs, Press & Release the BLACK button to store it in memory		This action will return you to the main configuration menu indicated by BOTH LEDs flashing quickly	
7		Turn OFF power to the Smart Actuator II™ and RESTART		N/A	

To Set Cable Direction for Actuator's LEVER 2, follow these steps:

It may become necessary to change the cable travel direction after calibration has been completed. If so, verify that you are changing the cable direction for the appropriate Actuator function by locating the Serial Number label located on the front (or top) of the Actuator. The ID number signifies that the Actuator has been set up for a particular propulsion arrangement. Actuator's LEVER 2 function depends on the Actuator ID switch setting (see below):

- ACT ID#1 or #2 — Gear lever on a throttle/gear Actuator
- ACT ID#3 — STBD Troll lever on a troll/troll Actuator
- ACT ID#4 — STBD Throttle lever on a throttle/throttle Actuator
- ACT ID#5 — STBD Gear lever on a gear/gear Actuator

To set the LEVER 2 of the **Actuator's** Cable Direction, follow the steps below:

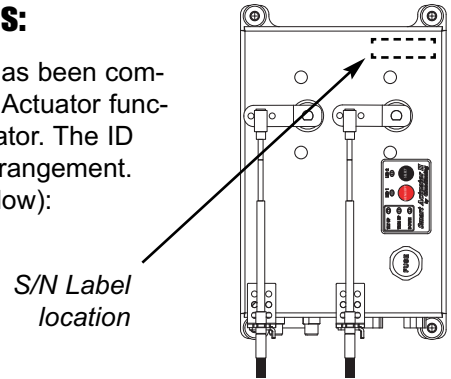

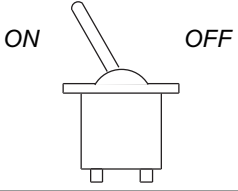
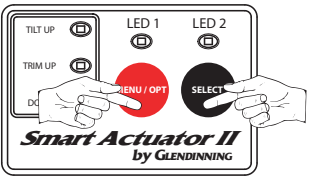
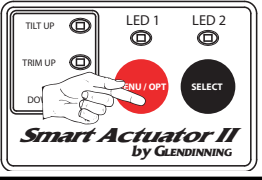
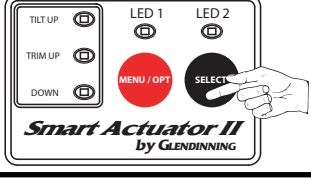
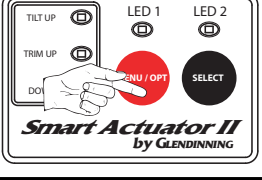
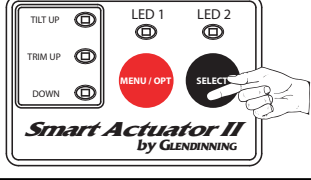
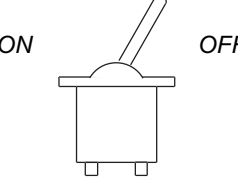
1		ACTION		RESULT	
		Turn power to Smart Actuator II™ ON		N/A	
2		Press & Release in sequence the RED then the BLACK then the RED buttons on the Smart Actuator (you have 5 seconds to complete process)		Both LEDs above the RED and BLACK buttons will flash to indicate that you have entered Smart Actuator II™ Configuration Mode	
3		Press & Release the RED button on the Smart Actuator 2 times to select LEVER 2 Cable Direction Menu		RED LED will flash two times, pause and then repeat	
4		Press & Release the BLACK button 1 time to select LEVER 2 cable direction configuration		The RED LED will continue to flash to show you what menu you are in. The BLACK LED will illuminate to indicate which selection you have chosen below.	
5		Press & Release the RED button until the desired Actuator cable direction is indicated by the LEDs (see chart at right)		LED 2 BLACK	TRAVEL DIRECTION
				FLASHES 1 TIME	PUSH direction
				FLASHES 2 TIMES	PULL direction
6		When the desired cable direction is displayed on the LEDs, Press & Release the BLACK button to store it in memory		This action will return you to the main configuration menu indicated by BOTH LEDs flashing quickly	
7		Turn OFF power to the Smart Actuator II™ and RESTART		N/A	

7.7 Triple Engine Applications (optional)

A. Description

The Smart Actuator System is able to control the throttles and transmissions for multiple engine applications. The control head handle is designed and programmed to control three engines from 2 handles. In order for the Smart Actuator System to control multiple engines, an additional Smart Actuator must also be installed (see layout drawing following this section).

B. Operation

When installed properly, the PORT engine control handle controls the port engine – functioning in the same way as a standard control. The STBD (starboard) engine control handle controls the starboard engine – functioning in the same way as a standard control.

PORT and STBD Engine Control:

After proper installation, the PORT engine control handle controls the PORT engine — functioning in the same way as a standard control. The STBD engine control handle controls the starboard engine — functioning in the same way as a standard control.

CENTER Engine Control:

For gear shift, the center engine is put into gear by moving BOTH the PORT and STBD engines into the same gear.

- If the PORT engine goes into gear, but the STBD engine is in Neutral or in the opposite gear (during maneuvering), then the CENTER engine stays in Neutral.
- If the STBD engine goes into gear, but the PORT engine is in Neutral or in the opposite gear (during maneuvering), then the CENTER engine stays in Neutral.
- However, if BOTH the PORT and STBD engine are placed into the same gear (either ahead or reverse), then the CENTER engine will respond the same way and shift into the same gear position as the PORT and STBD engine.

For throttle control, the engine speed of the CENTER engine will be the same as the lowest speed of either the PORT or STBD engine.



While in WARM mode, the center engine will respond the same way as above. However, the gear on all the engines will not respond while in WARM mode – all engines will remain in neutral.

Triple Engine Activation Switches

The position of the switches on the control panel at the helm station will determine which of the engines will respond to the control head. If all of the switches are in the ON position, then the engines will respond as described above. If any of the switches on the control panel are in the OFF position, then the engine associated with that switch will remain in the neutral / idle control position – the engine will not go into gear, it will not speed up.

If the center engine is turned off, then it will remain in neutral, while the port and starboard engines respond normally. If either the port or starboard engine switch are turned off, then the center engine will be controlled by the PORT or STBD control handle (whichever button is turned off). If ONLY the center engine switch is on, then the center engine will be controlled by the starboard handle.



The control system will only respond to a change in the switch position when the control handles are in neutral. Manipulating the switches while the engines are in gear will have no effect, until after the control handles are returned to neutral.

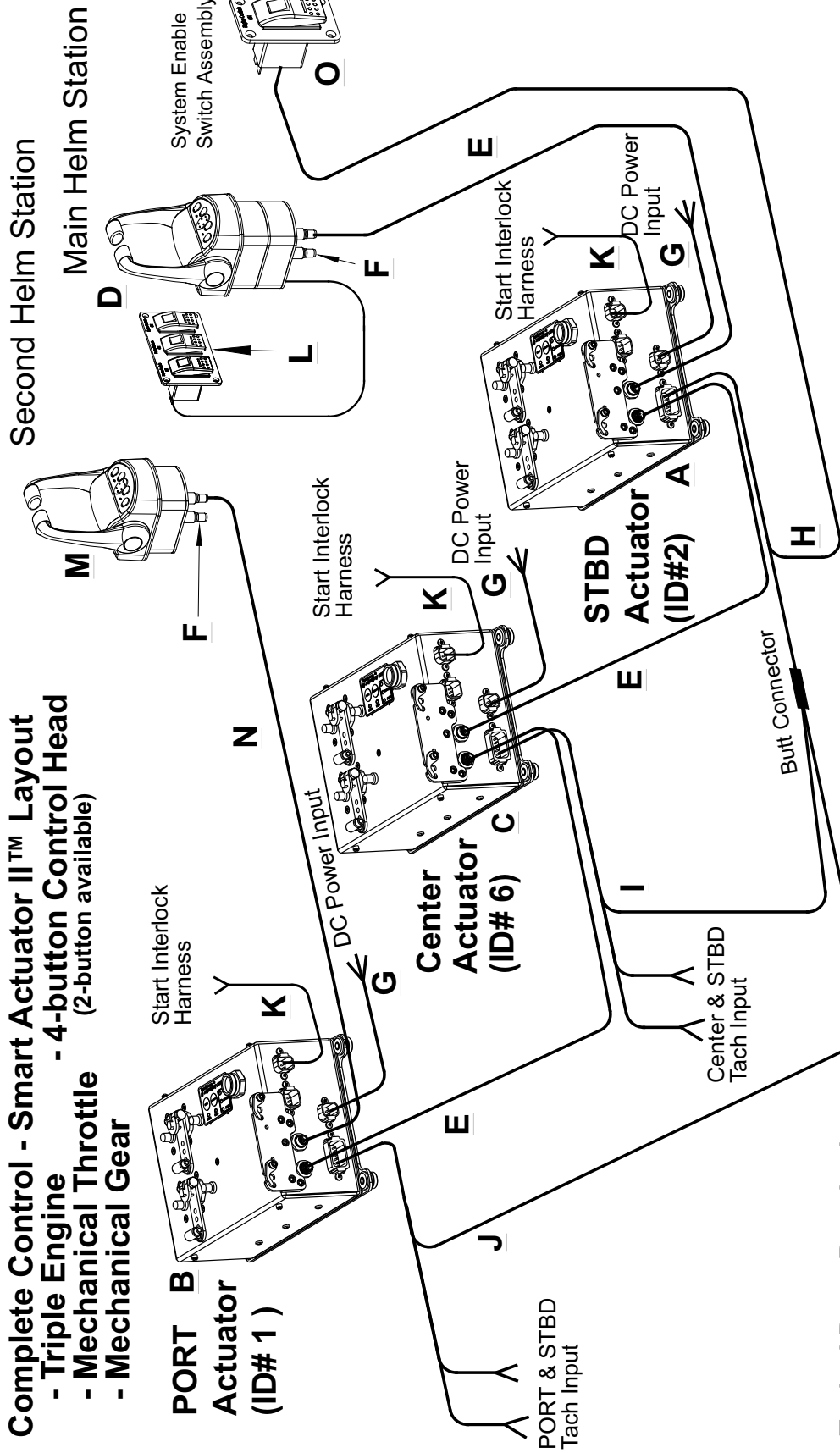

Complete Control - Smart Actuator II™ Layout
 - Triple Engine
 - 4-button Control Head
 (2-button available)
 - Mechanical Throttle
 - Mechanical Gear

Second Helm Station

Main Helm Station

Typical Parts Required

ITEM	QTY	PART#	DESCRIPTION	ITEM	QTY	PART#	DESCRIPTION
A	(1)	11314-XX-TMG-S	Smart Actuator II STBD (12 or 24VDC)	I	(1)	11603-02-P	Harness - Enable/Tach PORT (30' long)
B	(1)	11314-XX-TMG-P	Smart Actuator II PORT (12 or 24VDC)	J	(1)	11603-02-C	Harness - Enable/Triple Center Engine (30' long)
C	(1)	11314-XX-TMG-C	Smart Actuator II CENTER (12 or 24VDC)	K	(3)	11602-02	Harness - Start Interlock (20' long)
D	(1)	11413-CT-CP	CH2001 Control Head 4 button CP	L	(1)	11493	Triple Engine Switch Panel - White
E	(3)	11600-02-XX	Station Cables (20 - 100' long)	EXTRA CONTROL STATION REQUIRES			
F	(2)	11600-TRF	Terminating Resistors	M	(1)	11413-C15T	CH2001 Control Head 4 button
G	(3)	11601-01	Harness - DC Power Input (30' long std.)	N	(1)	11600-02-XX	Station Cable (20 - 100' long)
H	(1)	11603-02-S-XX	Harness - Enable STBD (20 - 100' long)	OPTIONAL ENABLE SWITCH ASSEMBLY			
				O	(1)	11490-X	Enable Switch Assembly (Black or White Nameplate)

Smart Actuator CENTER Harness
Part # 11603-02-C

CENTER

Engine End
- see GMP Tach sender #93111
- a meachnical drive adapter might be required (see section in manual for more info)

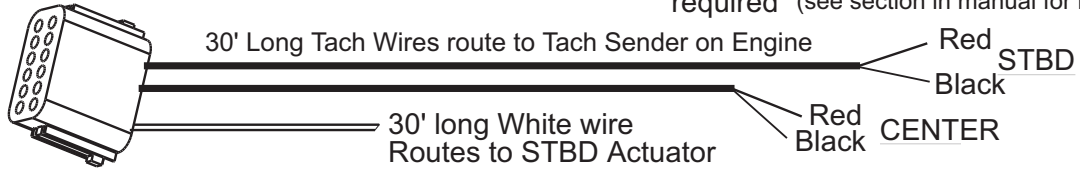

Control Process End
Duetsch 12 pos.
Grey

