

GLENDINNING

RV CABLEMASTER

RV Power Cable Storage System

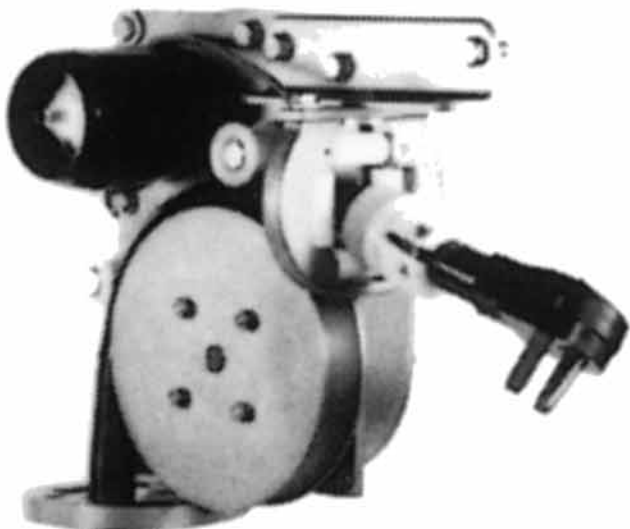

RVCM-7



RVCM-LC

GUIDE TO:

- DESCRIPTION
- INSTALLATION
- OPERATION



*RVCM-7
Package unit*



740 Century Circle
Conway, SC 29526

Phone: (843) 399-6146
Fax: (843) 399-5005
www.glendinningprods.com

TABLE OF CONTENTS

THANK YOU...	PAGE 1
INTRODUCTION	PAGE 1
GETTING TO KNOW YOUR RV-CABLEMASTER	PAGE 2
INSTALLATION OVERVIEW	PAGE 3
Location for the RV-Cablemaster	PAGE 3
Power Cable Exit	PAGE 3
Connection to Electrical System	PAGE 3
TYPES OF INSTALLATIONS	PAGE 4
INSTALLATION INSTRUCTIONS	PAGE 5
WIRING INSTRUCTIONS	PAGE 6
POWER CABLE INSTALLATION	PAGE 7
CABLE ADJUSTMENT	PAGE 7
AC WIRING INSTRUCTIONS	PAGE 8
MAINTENANCE	PAGE 8
OPERATION OF RV-CABLEMASTER	PAGE 8
TROUBLE SHOOTING GUIDE	PAGE 9
RV-CABLEMASTER DIMENSIONS	PAGE 10
RV-CABLEMASTER WIRING DIAGRAM	PAGE 11
RV-CABLEMASTER ACCESSORIES	PAGE 13

INTRODUCTION

Welcome to the Glendinning family of quality products. Your new *RV-Cablemaster* carries the same assurance of quality that has stood behind every product from Glendinning for over 30 years. Each *RV-Cablemaster* is manufactured under the strictest standards because we are proud of our reputation for quality products and service.

This manual is intended to provide you with the basic understanding of the *Glendinning RV-Cablemaster* and to familiarize you with the unit's installation. The *RV-Cablemaster's* installation will depend, to a large extent, on the specific coach. Some coaches are easy, while others make it more difficult to install.

The actual installation process is straightforward and uncomplicated, with one exception—it may be necessary to modify the 120 / 240 VAC electrical wiring. **This must be done properly and carefully to assure the safety of the coach and should be handled by someone who is qualified to work on this wiring.** In some cases, this will be within the capability of the coach owner. However, if there is any uncertainty as to the proper methods of working with AC wiring, a qualified and competent electrician should do this wiring.

If the installation is done properly, following common sense mechanical and electrical principles, and if the directions contained in this manual are followed, the *RV-Cablemaster* will provide many years of trouble-free service.

All *RV-Cablemasters* have been designed to pay out and retract your coach's RV power cable without overloading the motor within the system's power unit. Properly adjusted, a *RV-Cablemaster* will extend or retract the necessary amount of your RV power cable as is needed, limited only by your coach's power cable storage capacity.

The *RV-Cablemaster* consists of two major components; the power unit and storage container. There are two different models of power units to choose from: the RVCM-7 and the RVCM-LC. Consult the next page (2) for more information regarding the major differences between these two models. The storage container may either be an existing space or apparatus that allows the free fall and coiling of the RV power cable. Glendinning also has styrene storage containers available for purchase in a variety of sizes (see pg.14, Cablemaster Accessories).

ATTENTION:

In preparing this manual, Glendinning has relied upon the standards established by the National Electric Code and the recommended practices and standards for DC electrical systems.

This manual reflects practices and standards in effect at the time of publication and is intended only as a guide to understand the

RV-Cablemaster.

Glendinning will not be liable for any loss, damage, incidental or consequential damages of any kind, arising in connection with the use or reliance upon this manual.

THANK YOU...

for buying the Glendinning RV-Cablemaster. At Glendinning, we are committed to providing you, our customer, with a product that will yield trouble-free service. Care has been taken during each phase of the manufacturing process to guarantee a lifetime of quality and performance—after all, our name is on it!



Paul

John

Paul & John Glendinning

GETTING TO KNOW YOUR RV-CABLEMASTER

TWO MODELS TO CHOOSE FROM:

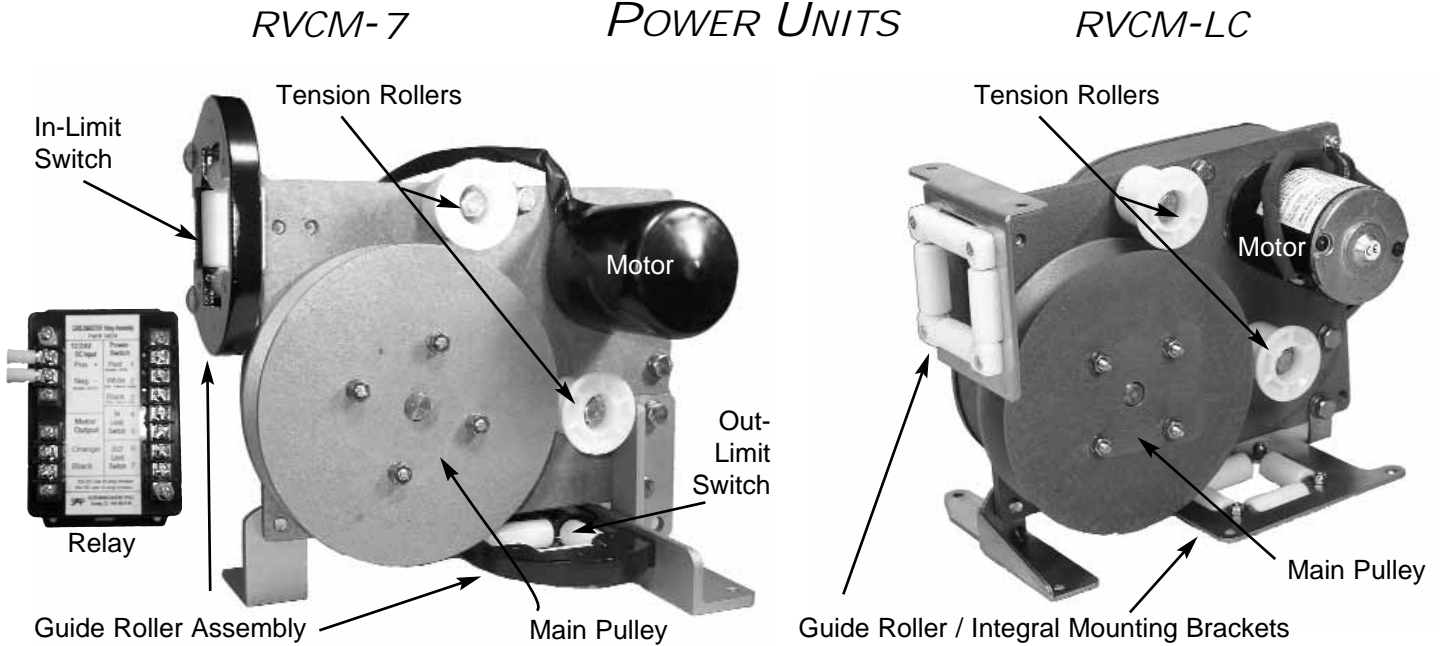

All Cablemasters are essentially the same in design and operation, however the RVCM-7 has extra features included which give the unit enhanced operational abilities. The major differences between the two models would be:

- 1) **Operation** — the RVCM-7 has in-limit and out-limit switches which automatically stop the motor when the cable has reached the end of travel in either direction. The RVCM-LC model requires the operator to flip the switch to the OFF position when the cable has reached the extent of its travel.
- 2) **Installation** — the RVCM-7 will require additional mounting brackets to install on your coach. The RVCM-LC has integral mounting brackets built-in to the design of the Guide Rollers.
- 3) **Options** — power to the RVCM-7 is wired through a relay which allows for the easy installation of the Radio Remote Control kit. In order to upgrade the RVCM-LC with the optional Remote Control kit, a relay must be purchased and installed.

Both of these units are available in the following configurations: **Basic** (power unit only), **Basic with cable** (power unit with 50 amp RV power cable), and **Package Unit** (includes power unit, cable, and storage container).

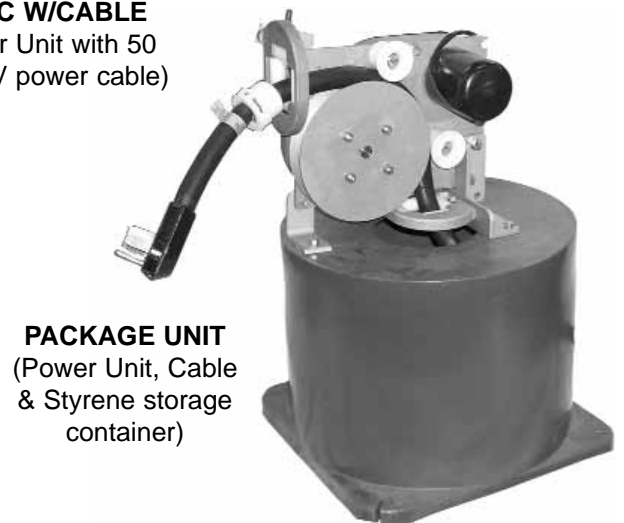
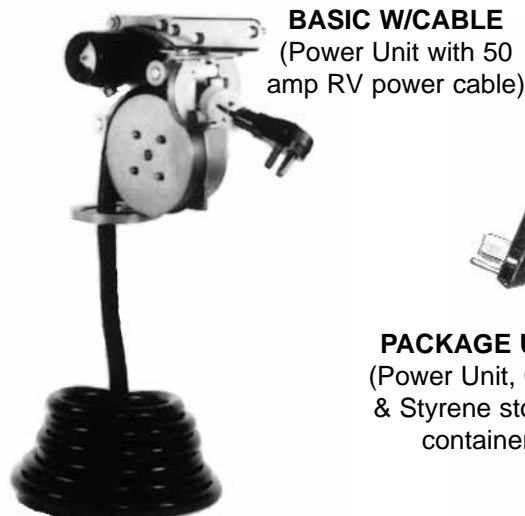



INSTALLATION OVERVIEW

BEFORE installing your *RV-Cablemaster*, consider the following three points:

Storage Bay
16"wx16"dx24"h
Space typically
needed for RV-
Cablemaster

1 LOCATION FOR THE RV-CABLEMASTER :

The first step in determining where to locate your *RV-Cablemaster* should be finding a suitable space where the cable will be stored when it is not in use. This location must be protected from the weather and must not contain combustible fuels.

The typical size requirement for the *RV-Cablemaster* is 16" square x 24" high with the Power Unit mounted directly above the cable storage area.

It must be emphasized that the Power Unit does not have to be mounted to the container. In limited space areas the Power Unit may be mounted separately. Many coach owners have successfully installed the *RV-Cablemaster* deep within the coach's interior by utilizing extensions that allow the power cable plug to exit the side or floor of the exterior (see section B, "Horizontal Extensions allow greater flexibility", page 4).

The approximate size for 35 feet of cable storage is an area about 16" wide by 16" deep by 13" high. This space can vary somewhat in both size and shape (square, circular or rectangular).

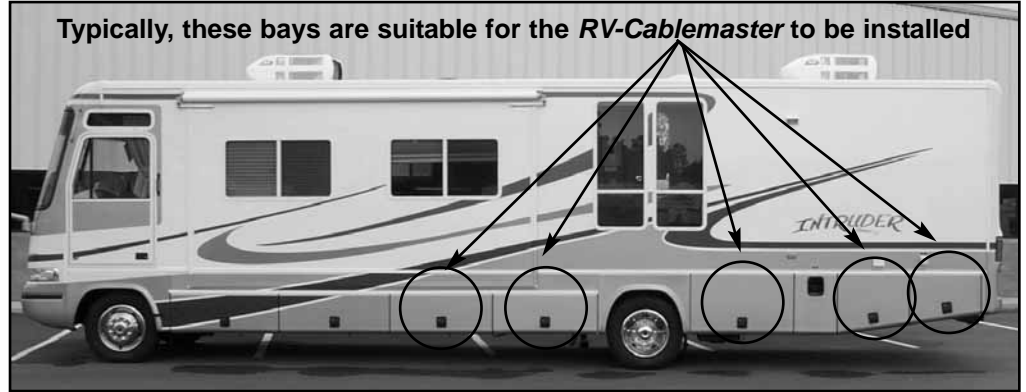

2 CABLE PLUG EXIT :



The second step is determining where the cable plug will exit the interior of the coach. In many coaches, the cable exits through an access hole on the bottom of the cable storage area or electrical hookup bay (see photo at left). In other cases, the power cable may exit the side of the coach through a new or existing access door (similar to a fuel door, see above). In either case, a route must be identified that the cable will take from where it is stored to the outside of the coach.



3 CONNECTION TO THE COACH ELECTRICAL SYSTEM :

A common misunderstanding concerning the installation of the *RV-Cablemaster* is how the unit is connected to the coach's electrical system. The drawing below demonstrates how this is accomplished.

The blunt cut end of the RV power cable (supplied with the *RV-Cablemaster*) should exit a hole in the bottom of the container. This end should be connected to the Power Transfer Switch which *automatically* switches power for your coach's electrical system between the on-board generator and the RV power cable hook-up.

The *RV-Cablemaster* is now "hard-wired" to your coach's electrical system. It is no longer necessary to use the power cord connection that was part of your RV's power system. The power cable of the *RV-Cablemaster* is all you need.

The power cable must be connected to the coach AC electrical system in accordance with the instructions contained in the National Electrical Code. Care should be taken when installing the out-limit switch to ensure that no strain will be placed upon the power cable connection to the electrical system.

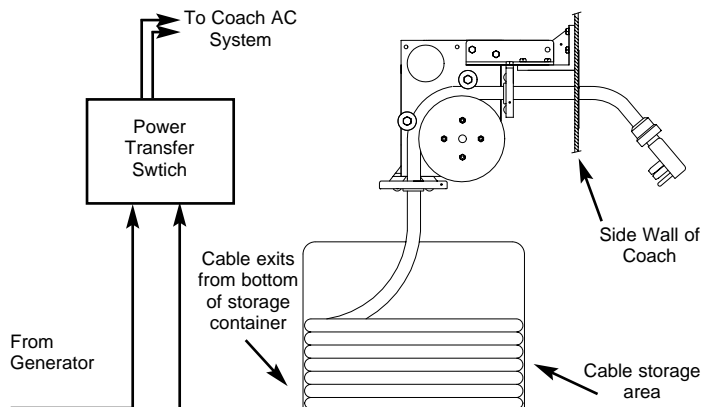



TYPES OF INSTALLATIONS

STANDARD (CLOSE COUPLED) INSTALLATION

The standard installation photo (see right) shows an installation that we describe as a “close coupled” installation and is the most basic arrangement possible. In this installation, the RV-Cablemaster is mounted to the coach with a storage area directly below it. This is our most typical installation and is preferred whenever space allows. This installation’s power cable capacity depends on the available storage space.



Standard Installation

The standard installation is obtained by mounting the power unit to the wall or ceiling of the coach storage area. There are 3 ways in which you may mount the power unit:

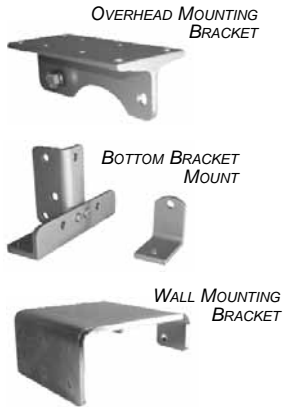

—USING THE OVERHEAD MOUNTING BRACKET. The overhead mounting bracket allows you to mount the power unit to the ceiling of the storage area where the RV-Cablemaster will be located.

—USING THE BOTTOM BRACKET MOUNT. When locating the RV-Cablemaster to a shelf within the storage area this bracket is required.

—USING THE WALL MOUNTING BRACKET. In configurations where it is necessary for the power unit to be mounted from the wall of the storage area a Wall Mounting Bracket should be used.

RV-CABLEMASTER PACKAGE UNIT

The next photo (right) shows a slight variation from the standard installation and is hoped can be used wherever possible in the RV market. This arrangement varies from the standard installation in the following ways:

- the RV-Cablemaster power unit is mounted on top of the container
- the RV-Cablemaster unit is designed to slide in “as is” to the existing storage bay of your coach.



RVCM-7 Package Unit

OTHER INSTALLATION LOCATIONS

There are several other ways in which our product can be installed which are not shown in drawings:

—THE STYRENE STORAGE CONTAINER SHOWN IN MANY OF OUR DRAWINGS OR PHOTOS IS NOT A REQUIREMENT. Partitioning off a section of the storage compartment is acceptable and often times preferred. The cable storage area does not have to be round or square, but could also be rectangular. However, the storage area does need to allow the power cable to freely fall into the space without restrictions, and be able to accommodate the required length of cable. Contact Glendinning for non-standard sizes and configurations.

—THE RV-CABLEMASTER DOES NOT NECESSARILY HAVE TO BE INSTALLED INSIDE AN EXISTING STORAGE AREA. On some older coaches, there are areas underneath the side “skirt” of the coach, especially in the rear end of the coach, that are essentially void—not being used for anything. In some cases, these areas can be used to install the RV-Cablemaster system.

—HORIZONTAL EXTENSIONS ALLOW GREATER FLEXIBILITY in locating your RV-Cablemaster unit further into the exterior “envelope” of the coach. As depicted in the photo to the right, the horizontal extension allows the RV-Cablemaster to be mounted a considerable distance from where the RV power cable actually exits the vehicle. This configuration allows space deep within the storage area to be utilized, freeing up valuable space towards the front of the compartment.

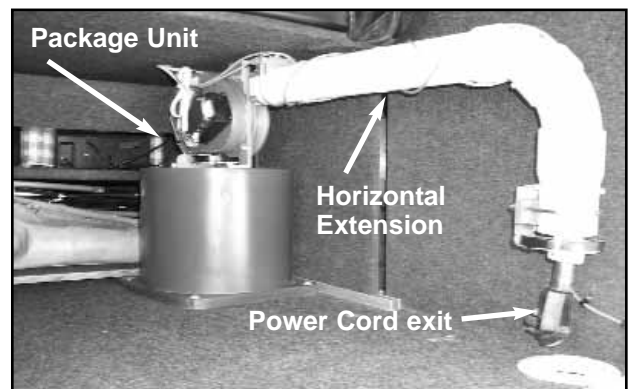

Extensions open up otherwise unreachable storage space

Hopefully, this has provided you with food for thought on ways in which our product can be installed in your particular coach. Please call us if we can be of any further assistance in installing the RV-Cablemaster in your motorhome.



INSTALLATION INSTRUCTIONS

The *RV-Cablemaster* system must be mounted in a location that is protected from the weather and that does not contain combustible fuels. Generally, the existing compartment where the storage cable is currently being stored is an acceptable location.

MOUNTING OVERHEAD

In general, the *RV-Cablemaster* system will be suspended from the overhead of the compartment where it will be located. The overhead mounting bracket (see *Section M, page 13, PN 50006*) can be used to support the power unit (this does not apply when using the *RV-Cablemaster* packaged unit or when mounting the power unit to the storage container).

Secure the overhead mounting bracket by using four (4) 1/4" diameter carriage or lag bolts (grade 5 or better). If carriage bolts are used, locknuts / lock washers should also be used to prevent unintended loosening. If the overhead mounting bracket is not used, aluminum or steel angle (1/4" thick minimum) should be used.

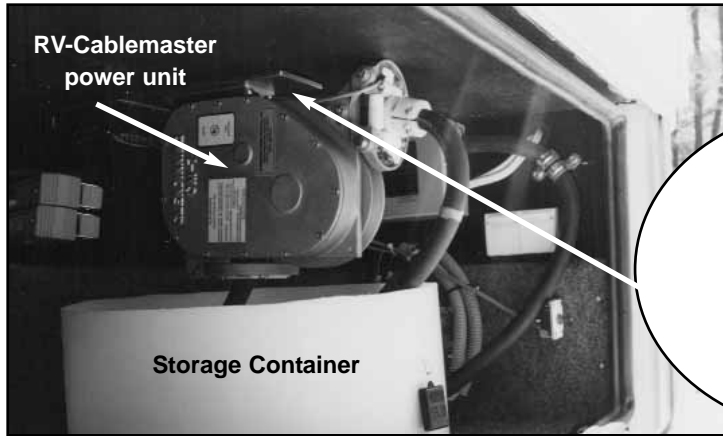

EXAMPLE OF OVERHEAD MOUNTING.

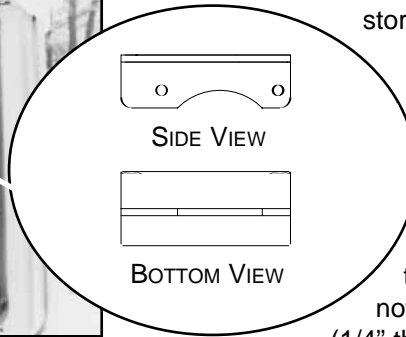

MOUNTING TO CONTAINER

As an alternative to overhead mounting, a "container-to-power unit mounting bracket" (see *Cablemaster Accessories, page 5, PN 50408*) can be used to mount the system above the storage container or on a horizontal "shelf."

In those cases where the "container-to-power unit mounting bracket" is not used in the installation, the cable storage container must be securely mounted to the coach to prevent movement during travel as well as ensure the relative locations of power unit and storage container are maintained.

MOUNTING PACKAGE UNIT

The *RV-Cablemaster* "package unit" has been designed to utilize many coaches' existing storage compartments and provides you with the easiest installation of our product. Locate an existing storage compartment that will accommodate the package unit's overall height. Simply slide the unit into the existing space and secure container to floor of storage area (before securing container make sure ample power cord exits the bottom of the container for wiring to coach electrical system).

You are now ready to connect the *RV-Cablemaster* to your coach's electrical system.

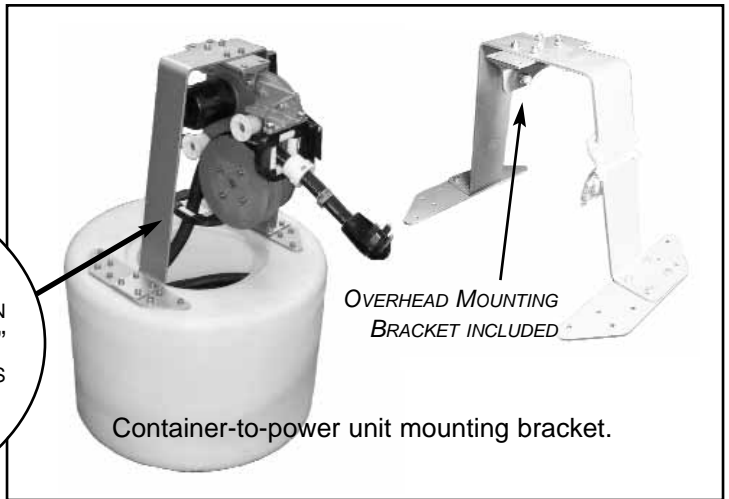
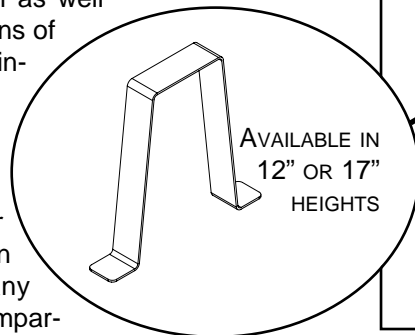

Container-to-power unit mounting bracket.



Package Unit slides into existing storage compartment for easy installation.



RV-CABLEMASTER WIRING INSTRUCTIONS (see wiring diagram, page 11)

Some wiring instructions are basic to the wiring of the *RV-Cablemaster* regardless what model (RVCM-7 or RVCM-LC) you purchased.

FIRST, all wiring should be done in accordance with the instructions contained in the National Electrical Code. If there is any uncertainty as to the proper methods of wiring, a qualified and competent electrician should do the wiring.

SECOND, overcurrent protection (fuse or circuit breaker) must be provided in the power supply to the *RV-Cablemaster*. On 12v DC systems, a 20 amp fuse or circuit breaker should be used; on 24v DC systems, a 10 amp fuse or circuit breaker is required. In addition to providing electrical "overload" protection, a separate breaker for the *RV-Cablemaster* allows the unit to be turned "off" thus preventing the unauthorized use of the unit when left unattended. *This is especially IMPORTANT if the switch is located where it can easily be actuated by children.*

Follow the instructions below for the specific model you purchased:

THE RVCM-7 POWER UNIT is wired through an integral relay assembly for 12 volt DC.

THE RELAY BOX can be attached to the *RV-Cablemaster* power unit or it may be mounted on a wall close by to the power unit. Make sure that the connecting wires are fastened away from the pulley and rollers.

All electrical connections to the relay assembly have been completed at the factory to make for easy installation. All that is required by the installer is to attach the battery to the appropriate terminals on the relay (see drawing above).

THE POWER SWITCH is normally mounted by first installing it in the nameplate provided. The nameplate should be securely mounted using four (4) #8 or larger screws. The location for the power switch / nameplate should be chosen such that the switch will not be in the way of normal *RV-Cablemaster* operation. Also, care should be taken during power switch mounting to eliminate the possibility of inadvertent contact with the terminals on the rear of the power switch during *RV-Cablemaster* operation. For convenience and ease of operation, the power switch should be mounted near the power cord exit. The power switch must also be protected by the neoprene cover to prevent the intrusion of moisture).

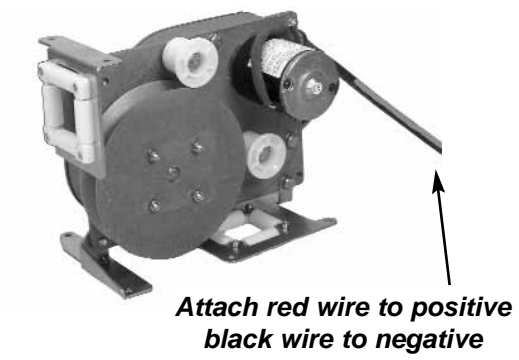

**Attach red wire to positive
black wire to negative**

SECOND, attach battery power leads to the red (positive) and black (negative) wires on the RVCM-LC power unit.

TYPICAL RVCM-7 RELAY ASSEMBLY WIRING

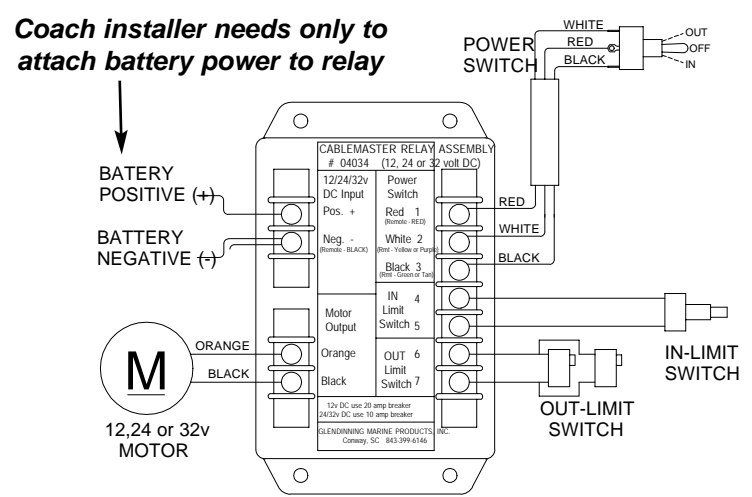

THE RVCM-LC POWER UNIT does not utilize a relay assembly, therefore the wiring is somewhat different than that described above.

FIRST, install the RVCM-LC power switch assembly. The power switch is normally mounted by first installing it in the nameplate provided. The nameplate should be securely mounted using four (4) #8 or larger screws. The location for the power switch assembly should be chosen such that the switch will not be in the way of normal *RV-Cablemaster* operation. Also, care should be taken during power switch mounting to eliminate the possibility of inadvertent contact with the terminals on the rear of the power switch during *RV-Cablemaster* operation. For convenience and ease of operation, the power switch should be mounted near the power cord exit or in the appropriate hole within the optional bezel. In each case, the power switch must be protected by the neoprene cover to prevent the intrusion of moisture).



POWER CABLE INSTALLATION

Before installing the power cable into the *RV-Cablemaster*, stretch the cable out in a straight line on a smooth surface to remove any kinks or unnatural coils. Feed the terminal end of the cable into the power unit. Retract the power cable, using the power switch or manually. Before connecting the power cable to the coach's AC electrical system, secure the nylon safety collar and refer to the Cable Adjustment section below to pre-adjust the pulley to the proper cable size and to insure trouble-free operation of your *RV-Cablemaster*. The power cable should be firmly strapped down, using metal or heavy duty plastic wiring straps, to the bottom of the cable storage area so that in no way will the *RV-Cablemaster* pull on the power cable's electrical connection.

In actual usage of your *RV-Cablemaster*, you will find that the power cable is seldom payed out completely. Because of this, it is advisable to occasionally pay out the cable completely and allow the cable to recoil into its natural coil.

The power cable must be connected to the coach AC electrical system in accordance with the instructions contained in the National Electrical Code. Care should be taken when adjusting the out-limit collar to ensure that no strain will be placed upon the power cable connection to the electrical system.

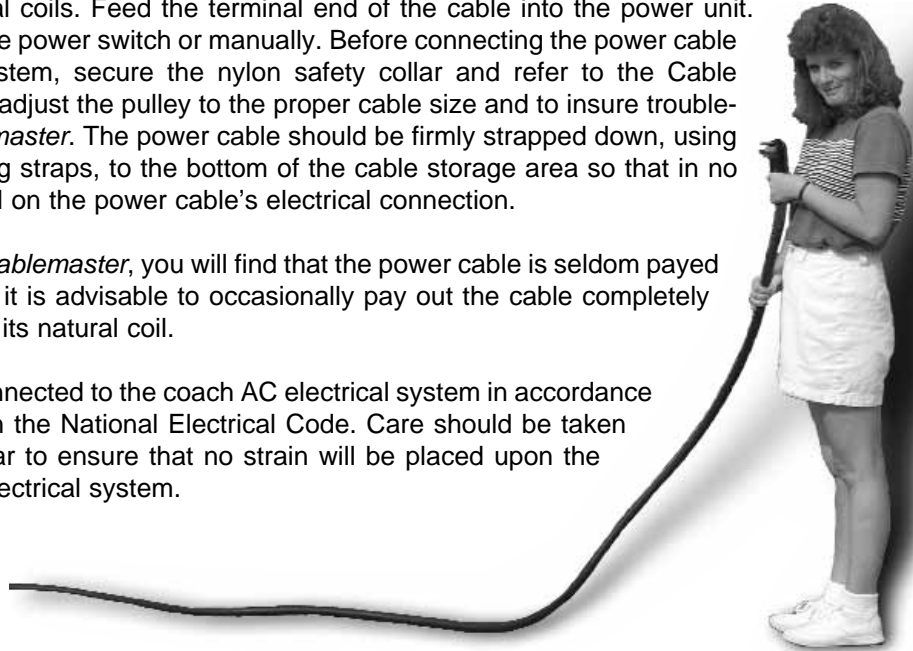

CABLE ADJUSTMENT

During assembly at the factory, each *RV-Cablemaster* is set up for 50 amp - 6/4 power cable. There should be enough friction between the main pulley and the power cable to allow the cable to be pulled in and out without slippage. The *RV-Cablemaster* should be able to pay in and out the cable without any slippage or any undue strain. One easy diagnostic test to determine if the pulley is properly adjusted, would be to manually pull out the power cable. If it is very hard or does not move at all then the main pulley is too tight on the cable and should be adjusted.

Power cable diameters vary from one cable manufacturer to another, the *RV-Cablemaster's* main pulley is split in half and proper friction adjustment between the cable and main pulley is necessary at the time of installation. Too tight adjustment will overload the motor. On the other hand, too loose an adjustment will result in slippage of the cable or no movement of the cable.

To adjust the friction between the main pulley and the power cable follow the instructions below:

- 1) Remove the 1/4" nuts and lockwashers from the face of the main pulley and remove the outer pulley half.
- 2) Remove or add* only equal amounts of spacers for each bolt.
- 3) Replace the pulley half and secure the nuts.

**When adjusting pulley friction, only add (decreases tension) or remove (increases tension) one (1) spacer from each bolt before checking the unit for the correct pulley friction. One spacer makes a substantial difference in cable tension.*

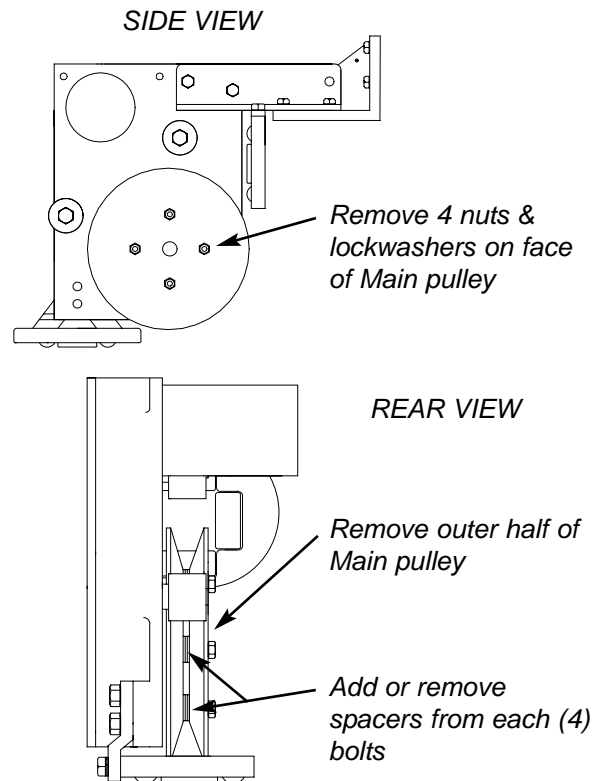



AC WIRING INSTRUCTIONS

WARNING: It is extremely important that the wiring of the power cord to the coach's electrical system be done properly. If there is any uncertainty as to the proper methods of working with AC wiring, a qualified and competent electrician should do this wiring. Failure to wire correctly may result in DEATH, INJURY, OR DAMAGE TO PERSONS OR VEHICLE.

Electricity enters the RV through the power cable. The cable is connected to the Power Transfer Switch which automatically switches power for your coach's electrical system between the on-board generator and the RV power cable hook up. The Power Transfer Switch is then connected to the AC panel board through a main circuit breaker. The power is transferred to the various branch circuits by way of individual branch circuit breakers.

In all electrical applications, minimizing the entrance or accumulation of moisture or water is of prime importance. Junction boxes, receptacles, breakers and other enclosures in which electrical connections are made should be waterproof or be installed in a protected area.

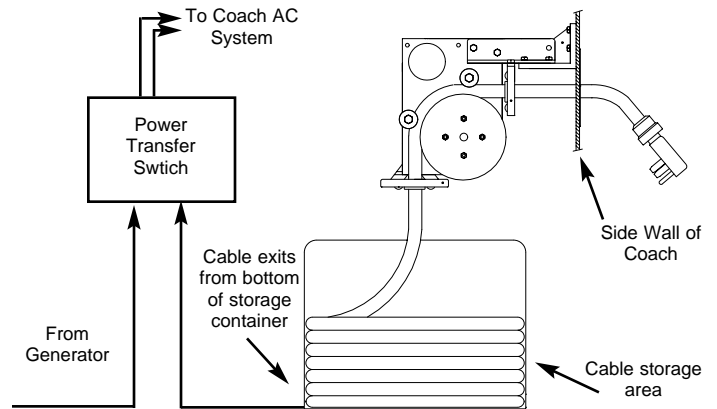

MAINTENANCE

Experience has shown that when only a short section of the power cable is regularly used, the cable may be subject to sharper than normal coiling which in turn causes undue "kinking" of the cable. To relieve this condition, routinely pay the cable out completely and stretch it on any smooth surface. Allow the *RV-Cablemaster* to then retract the cable into the RV storage area.

At least once a year, check all AC and DC wiring connections to be sure they are secure and free of corrosion. Check the neoprene covers on the in-limit switch and power switch to be sure they are free of cracks or fracture.



OPERATION OF THE RV-CABLEMASTER

RVCM-7 OPERATING INSTRUCTIONS:		RVCM-LC OPERATING INSTRUCTIONS:	
TO EXTEND CABLE	TO RETRACT CABLE	TO EXTEND CABLE	TO RETRACT CABLE
<ol style="list-style-type: none"> 1) Flip the power switch to OUT position; grasp the power cord plug. 2) Walk to park power source and plug power cord into receptacle. 3) RV-Cablemaster will automatically shut itself OFF when cable has fully extended. If less cable is more desirable, turn switch OFF and place in the IN position. 4) Turn power switch OFF when desired cable length is achieved. 	<ol style="list-style-type: none"> 1) Disconnect the power cord plug from the park power source. 2) While holding power plug, walk to RV-Cablemaster. 3) Flip the power switch to the IN position. 4) RV-Cablemaster will automatically shut itself OFF when cable has fully retracted. <p>** Do not move vehicle until cable is fully retracted!</p>	<ol style="list-style-type: none"> 1) Flip the power switch to OUT position; grasp the power cord plug. 2) Allow needed amount of power cable to extend. 3) Release Power Switch, Cablemaster will shut OFF. 4) Walk to park power source and plug power cord into receptacle. 	<ol style="list-style-type: none"> 1) Disconnect the power cord plug from the park power source. 2) While holding power plug, walk to RV-Cablemaster. 3) Flip the power switch to the IN position. 4) Release Power Switch, Cablemaster will shut OFF. <p>** Do not move vehicle until cable is fully retracted!</p>



TROUBLE SHOOTING GUIDE

COMPLAINT	PROBABLE CAUSE	RECOMMENDED ACTION
Non-functional (either no power or unit has power and does not respond)	<ul style="list-style-type: none"> ○ Tripped breaker ○ Power wire incorrectly connected to relay assembly ○ Defective motor ○ Defective relay box 	<ul style="list-style-type: none"> ○ Reset breaker ○ Replace relay assembly ○ With power switch on and voltage across motor wires — remove motor wires from relay box before applying power — if no response, replace motor
Pays out cable only	<ul style="list-style-type: none"> ○ Limit switch circuit open ○ Power inputs reversed ○ Defective relay or diode ○ Bad power switch 	<ul style="list-style-type: none"> ○ Check in-limit switch ○ Check polarity on DC input wires ○ Replace relay assembly ○ Check power switch
Retracts cable only	<ul style="list-style-type: none"> ○ Limit switch circuit open ○ Defective relay ○ Bad power switch 	<ul style="list-style-type: none"> ○ Check out-limit switch ○ Replace relay assembly ○ Check power switch
Tripped DC breaker	<ul style="list-style-type: none"> ○ Main pulley too tight ○ Cable jammed and kinking ○ Defective motor 	<ul style="list-style-type: none"> ○ Adjust pulley ○ Check for adequate storage space and/or cable for undue kinking — see Cable Adjustment (pg. ?) ○ Apply power directly to motor wires; motor should run one direction or other — remove motor wires from relay box before applying power— no response from motor; replace motor

GLENDINNING Marine Products, Inc.
 740 Century Circle Conway, SC 29526
 Phone: 843-399-6146 Fax: 843-399-5005



Model CM-7-12VDC RV Cablemaster (PN 04012)
Model CM-7-24VDC RV Cablemaster (PN 04013)

Voltage/Current: Model CM-7-12VDC: 12 VDC / 20 Amps
 Model CM-7-24VDC: 24 VDC / 10 Amps

For use with Flexible Cables: Type S, ST, STO, SO, or SE
 6 gauge (125/250 Volt, 50 Amp)
 55' maximum length

Cable Temp. Rating: 75 degrees C. (minimum)

Overcurrent Protection Required: Model CM-7-12VDC: 20 Amps fuse
 Model CM-7-24VDC: 10 Amps fuse

LISTED CABLE REEL 7F32

 "General - Use Cord Reel Only"

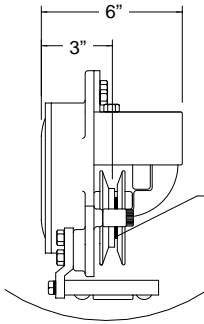

RV-CABLEMASTER DIMENSIONS

RVCM-4 DIMENSIONS



NOTE: SPACERS PROVIDED FOR VARIABLE CABLE DIAMETER ADJUSTMENT

NOTE: MAY SWING UP TO 45 DEGREES

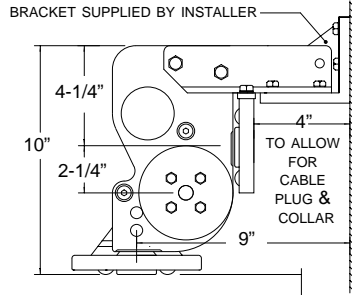
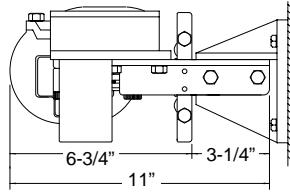

MINIMUM CABLE AREA REQUIRED:
HEIGHT — 15" FOR 40' OF 30AMP / 110V CABLE
DIAMETER — 14" MINIMUM DIAMETER

RVCM-7 PACKAGE UNIT DIMENSIONS

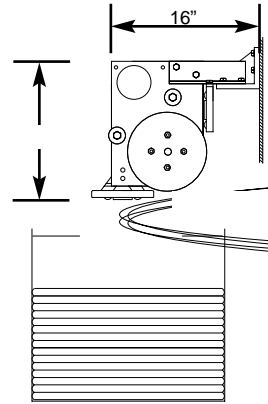
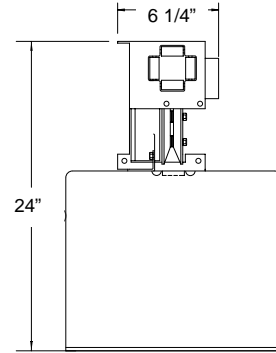

RVCM-7 DIMENSIONS

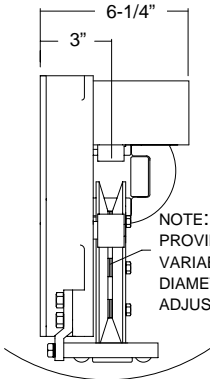

NOTE: SPACERS PROVIDED FOR VARIABLE CABLE DIAMETER ADJUSTMENT

NOTE: MAY SWING UP TO 45 DEGREES

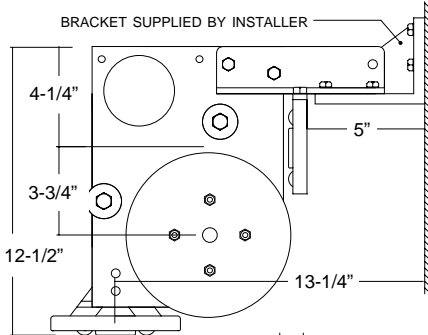
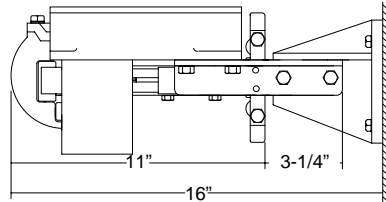

MINIMUM CABLE AREA REQUIRED:
35' SOFT CABLE (SOW) 14" x 14" x 16"H
35' STIFF CABLE (STW) 16" x 16" x 16"H

RVCM-LC PACKAGE UNIT DIMENSIONS

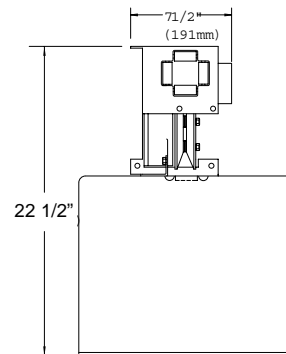

RVCM-LC DIMENSIONS

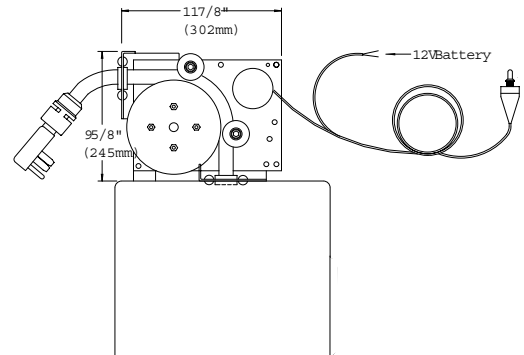
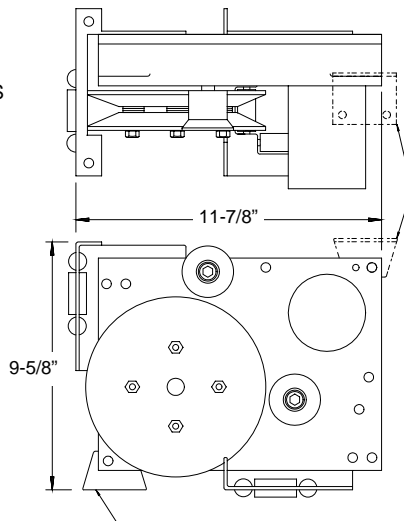
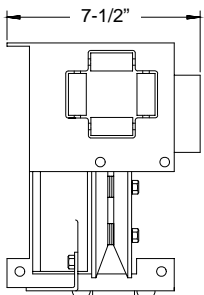



RV-CABLEMASTER WIRING DIAGRAM

*RVCM-7 WIRING DIAGRAM
RELAY ASSEMBLY*

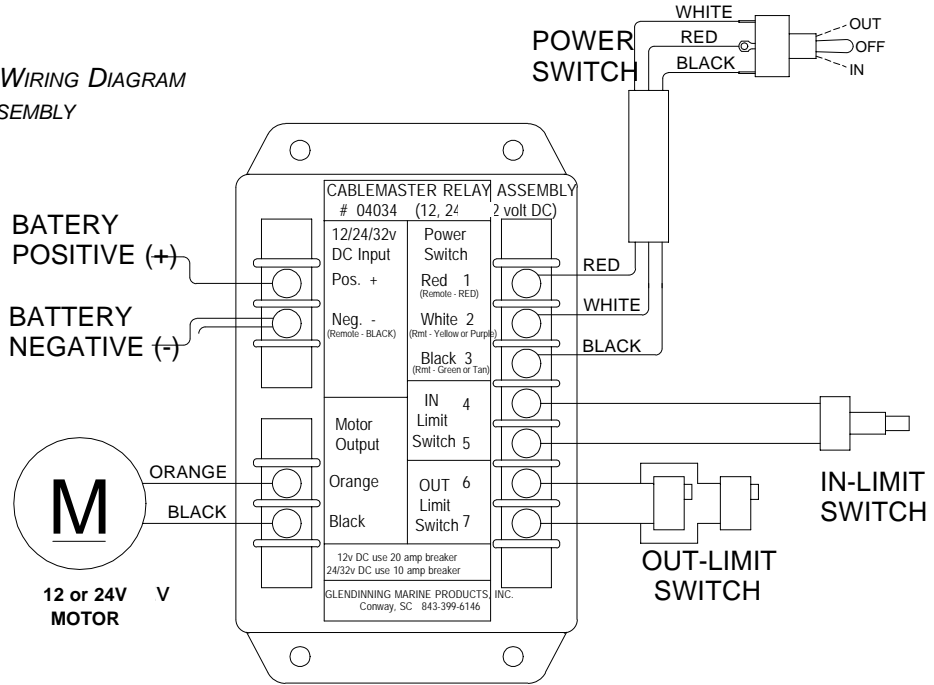

RVCM-LC WIRING DIAGRAM

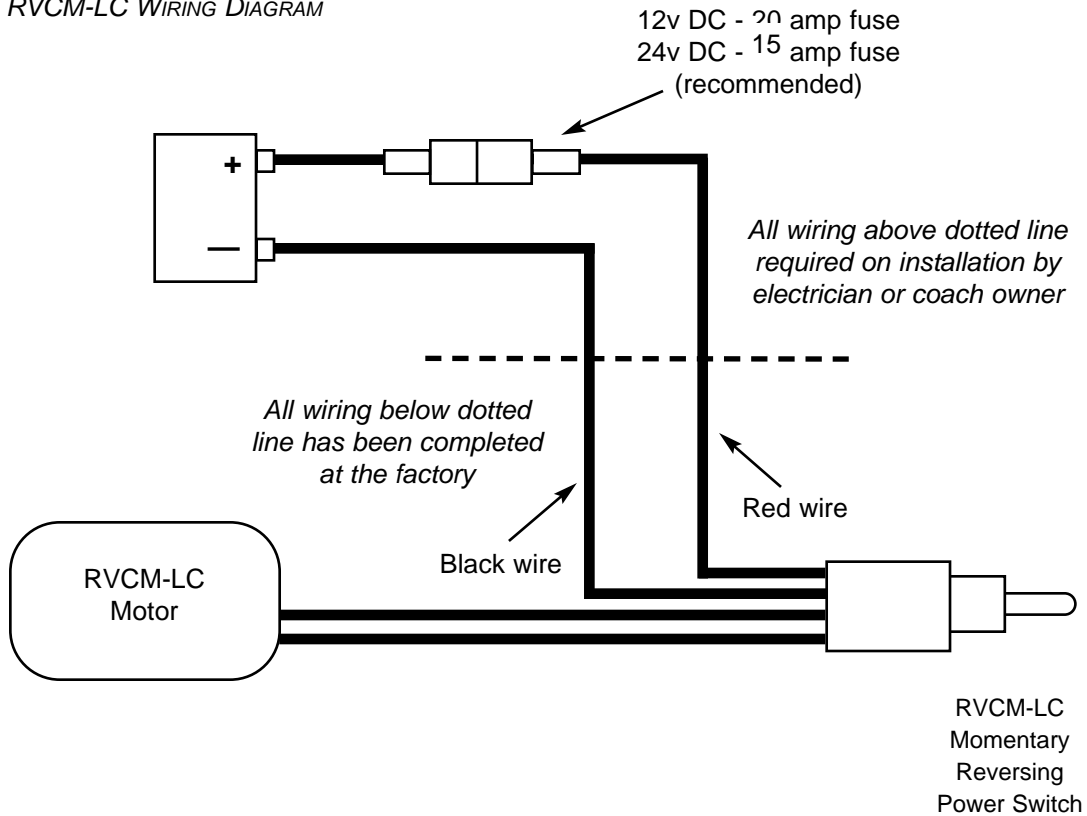

WARRANTY



PRODUCT COVERED BY THIS LIMITED WARRANTY: RV-CABLEMASTER

1. *GLENDINNING MARINE PRODUCTS, INC.* warrants to the original consumer purchaser that the RV-Cablemaster will be free from defects in material and workmanship under normal use and service for a period of one (1) year from the date of purchase.
2. *This LIMITED WARRANTY applies to* defects in material and workmanship. It does not apply to chromeplated or anodized finish or to power cable damage caused by inadequate cable storage area or installation not in accordance with *GLENDINNING MARINE PRODUCTS, INC.* specifications.
3. *This LIMITED WARRANTY is void* if the product has been damaged by accident or unreasonable use, neglect, improper installation, or other causes not arising out of defects in material or workmanship.
4. *To obtain performance of this LIMITED WARRANTY* obligation the original purchaser should contact *GLENDINNING MARINE PRODUCTS, INC.* for instructions concerning removal and shipping of the defective component. Upon compliance of the foregoing procedure all warranted defects will be repaired, or at *GLENDINNING MARINE PRODUCTS, INC.* option, the complete unit replaced and returned to the consumer, shipping charges prepaid.
5. *GLENDINNING MARINE PRODUCTS, INC.* does not assume the costs of removal and/or installation of the product or any other incidental costs which may arise as a result of any defect in materials or workmanship.

THIS WARRANTY IS IN LIEU OF ALL OTHER EXPRESS WARRANTIES. ANY WARRANTY IMPLIED BY LAW INCLUDING WARRANTIES OF MERCHANTABILITY OR FITNESS, IS IN EFFECT ONLY FOR THE DURATION OF THE EXPRESS WARRANTIES SET FORTH IN THE FIRST PARAGRAPH ABOVE. NO REPRESENTATIVE OR PERSON IS AUTHORIZED TO GIVE ANY OTHER WARRANTY OR TO ASSUME FOR *GLENDINNING MARINE PRODUCTS, INC.* ANY OTHER LIABILITY IN CONNECTION WITH THE SALE OF IT'S PRODUCTS. *GLENDINNING MARINE PRODUCTS, INC.* WILL NOT BE LIABLE FOR ANY CONSEQUENTIAL DAMAGES RESULTING FROM THE USE OR INSTALLATION OF IT'S PRODUCTS.

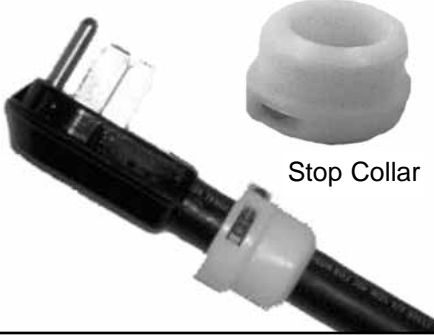

RV-CABLEMASTER ACCESSORIES

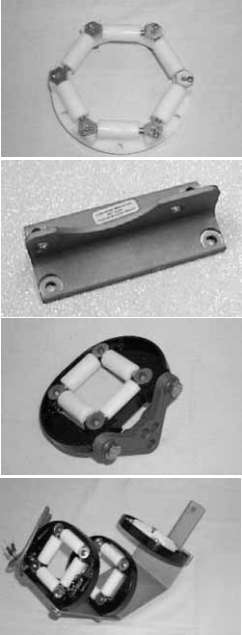
PART NUMBER	DESCRIPTION	
04132 04135 04131 04136 04130 04134 04133	<p>RV POWER CORD ASSEMBLIES — <i>flexible type SOW power cable with molded 50amp plug on one end and blunt cut on the other end.</i></p> <p>36' RV Power Cable Assembly 40' RV Power Cable Assembly 45' RV Power Cable Assembly 50' RV Power Cable Assembly 55' RV Power Cable Assembly 65' RV Power Cable Assembly 75' RV Power Cable Assembly</p>	 <p>Stop Collar</p>
04146 04147 04153 04034	<p>RADIO REMOTE CONTROL OPTION — <i>this option allows the remote operation of the RV-Cablemaster unit. This option is not available for the RVCM-LC models unless a relay box is installed.</i></p> <p>Radio Remote Control Kit - includes 2 transmitters! Spare / replacement transmitter RF Noise Filter - improves operational range of transmitter Relay Unit - required for addition of Remote on LC models</p>	
85448 85424 85420 85421	<p>POWER CABLE STORAGE CONTAINERS — <i>rotationally molded styrene containers used to store RV power cord.</i></p> <p>16" diameter x 13" height — approx. capacity of 40' of cable 18" diameter x 18" height — approx. capacity of 55' of cable 20" diameter x 18" height — approx. capacity of 75' of cable 22" diameter x 15" height — approx. capacity of 75' of cable</p>	
04069 50006 04054 04068 04052	<p>INSTALLATION ACCESSORIES — <i>these accessories are used to aid in installation of the RV-Cablemaster unit.</i></p> <p>Undercoach Roller Assembly — keeps cable from chaffing on sharp edges Overhead Mounting Bracket — allows RVCM to be mounted to the overhead of a storage compartment Guide Roller Assembly — aids the cable by allowing it to freely retract or extend Cable Diverter Assembly (down coverter) — guides the cable in a downward direction; used for cable exiting compartment floor Pipe Clamp Assembly (single) — <i>not pictured</i>; allows 3" PVC pipe to be mounted if necessary</p>	



HAZARDS STATEMENT

DANGER: ELECTRICAL CORD REELS CAN BE HAZARDOUS. MISUSE CAN RESULT IN FIRE OR DEATH BY ELECTRICAL SHOCK. PLEASE READ CAREFULLY AND FOLLOW INSTRUCTIONS:

- A cord reel marked for indoor use is to be used indoors only.
- Inspect thoroughly before each use. DO NOT USE if damaged.
- Look for the number of watts or amperes on appliances to be plugged into cord reel.
- See label on cord reel for specific watts or amperes.
- DO NOT plug more than the specified number of watts or amperes into this cord reel.
- DO NOT run through doorways, holes in ceilings, walls or floors.
- Make sure appliance is OFF before connecting cord reel to outlet.
- FULLY INSERT plug into outlet.
- DO NOT remove, bend or modify any metal prongs or pins of cord reel.
- DO NOT use excessive force to make connections.
- DO NOT connect a three-prong plug to a two-prong cord reel.
- Keep away from water.
- DO NOT USE WHEN WET.
- Keep children and pets away from cord reel.
- DO NOT plug one cord reel into another.
- AVOID OVERHEATING.
- DO NOT cover with any materials.
- DO NOT drive, drag, or place objects over cord.
- DO NOT walk on cord.
- GRASP PLUG to remove from outlet.
- Always store cord reels INDOORS.
- Always unplug when not in use.
- DO NOT unplug by pulling on cord.

THIS IS A POLARIZED CORD REEL



RV-CABLEMASTER PRODUCT REGISTRATION

Please take a moment to validate your product warranty by mailing in this card with the proper information.

FOLLOW THESE SIMPLE STEPS :

- STEP 1: Fill in the registration card.
- STEP 2: Cut along dotted line.
- STEP 3: Affix correct postage.
- STEP 4: Drop in mailbox.

*OR SEND VIA FAX TO:
(843) 399-5005*



RV-CABLEMASTER WARRANTY REGISTRATION

NAME _____

ADDRESS _____

CITY _____ STATE _____ ZIP _____

COUNTRY _____ PHONE _____ EMAIL _____

COACH MODEL & YEAR OF MANUFACTURE _____

RV-CABLEMASTER SERIAL NUMER _____

WHAT WOULD YOU LIKE TO SEE IMPROVED / CHANGED? _____

WOULD YOU LIKE TO RECEIVE INFO ON
NEW PRODUCTS FROM GLENDINNING?
YES NO

THANK YOU!

PRODUCT WARRANTY INFORMATION

PLACE
STAMP
HERE



**740 CENTURY CIRCLE
CONWAY, SC 29526-8274
USA**