

THE INFORMATION CONTAINED IN THIS DRAWING IS THE SOLE PROPERTY OF Glendinning Marine Products Inc. ANY REPRODUCTION IN PART OR WHOLE WITHOUT THE WRITTEN PERMISSION OF Glendinning Marine Products Inc. IS PROHIBITED.

REV	DESCRIPTION	ECN #	INIT	DATE
A	INITIAL RELEASE	4842Pn	MMR	7/10/08

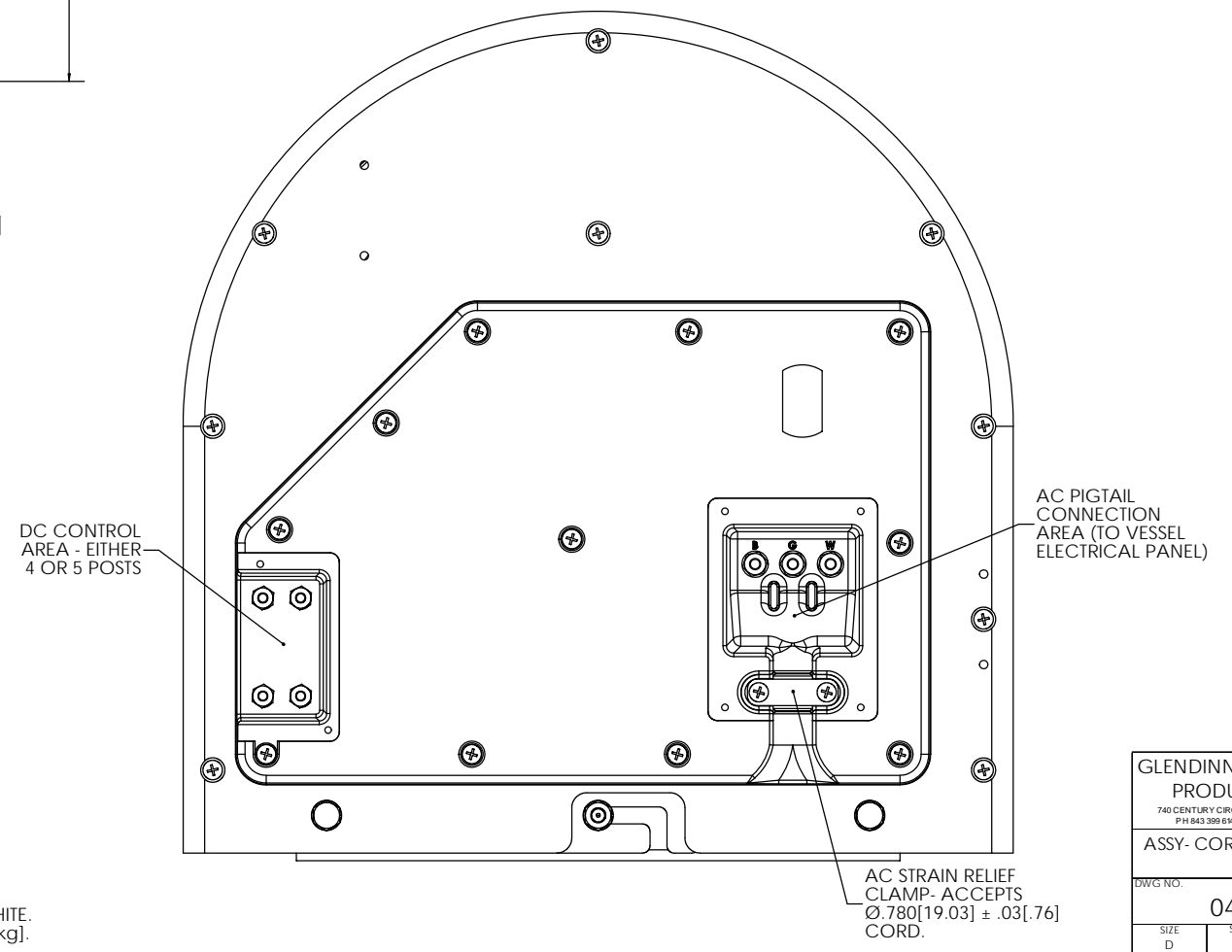
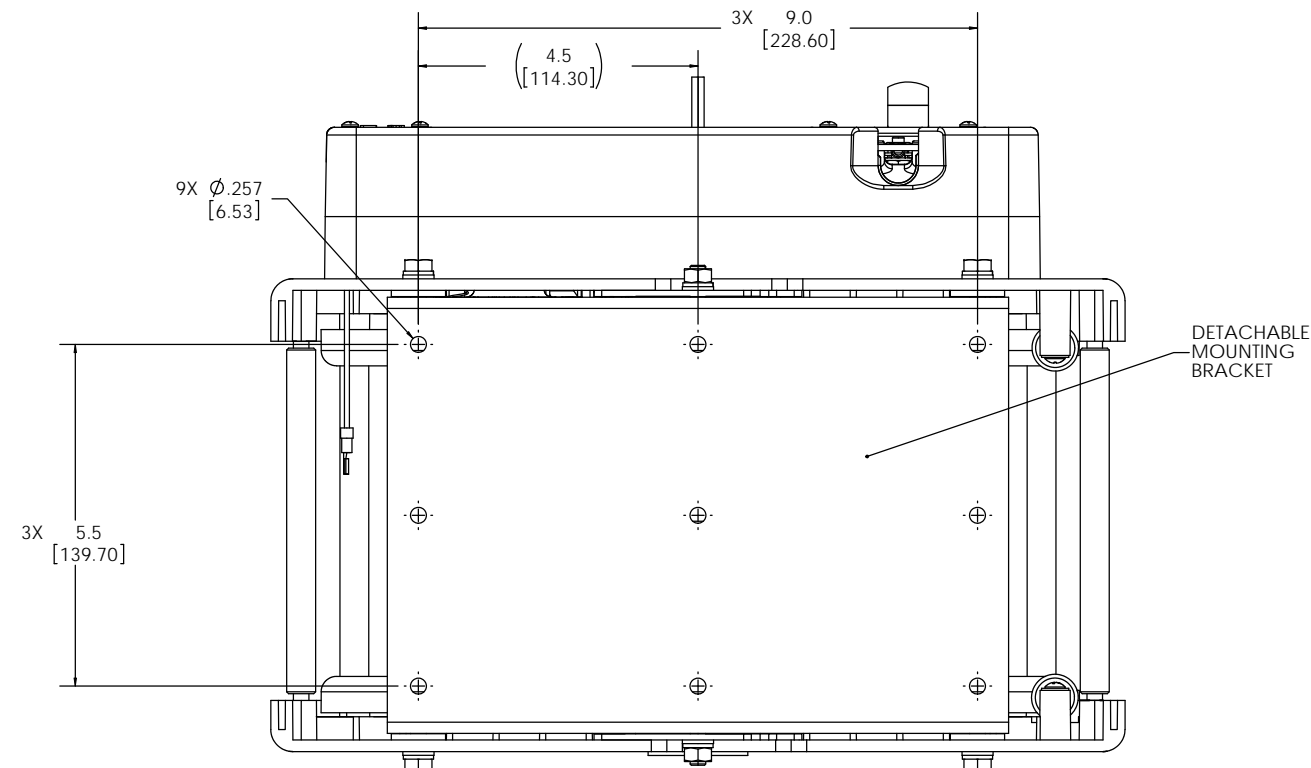
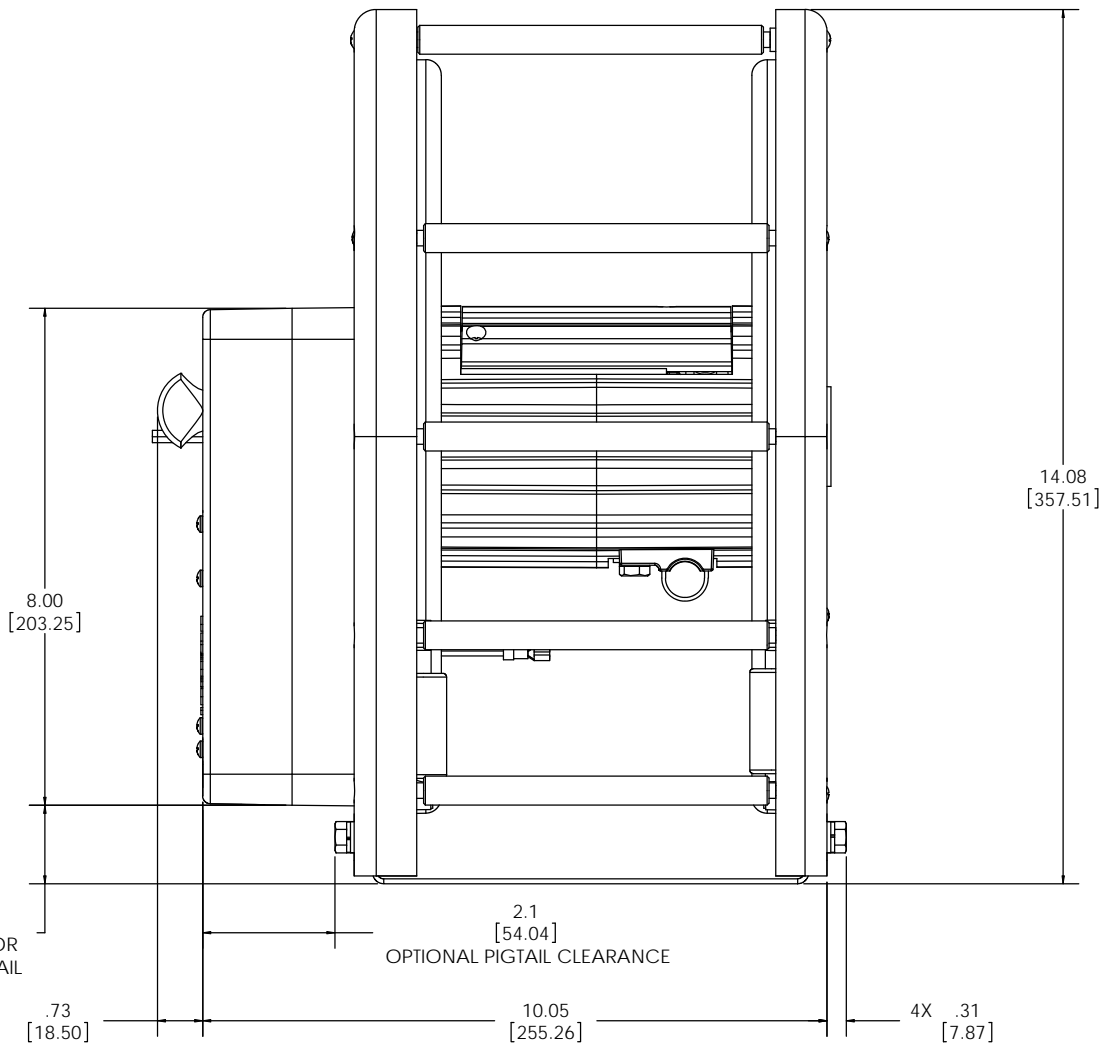
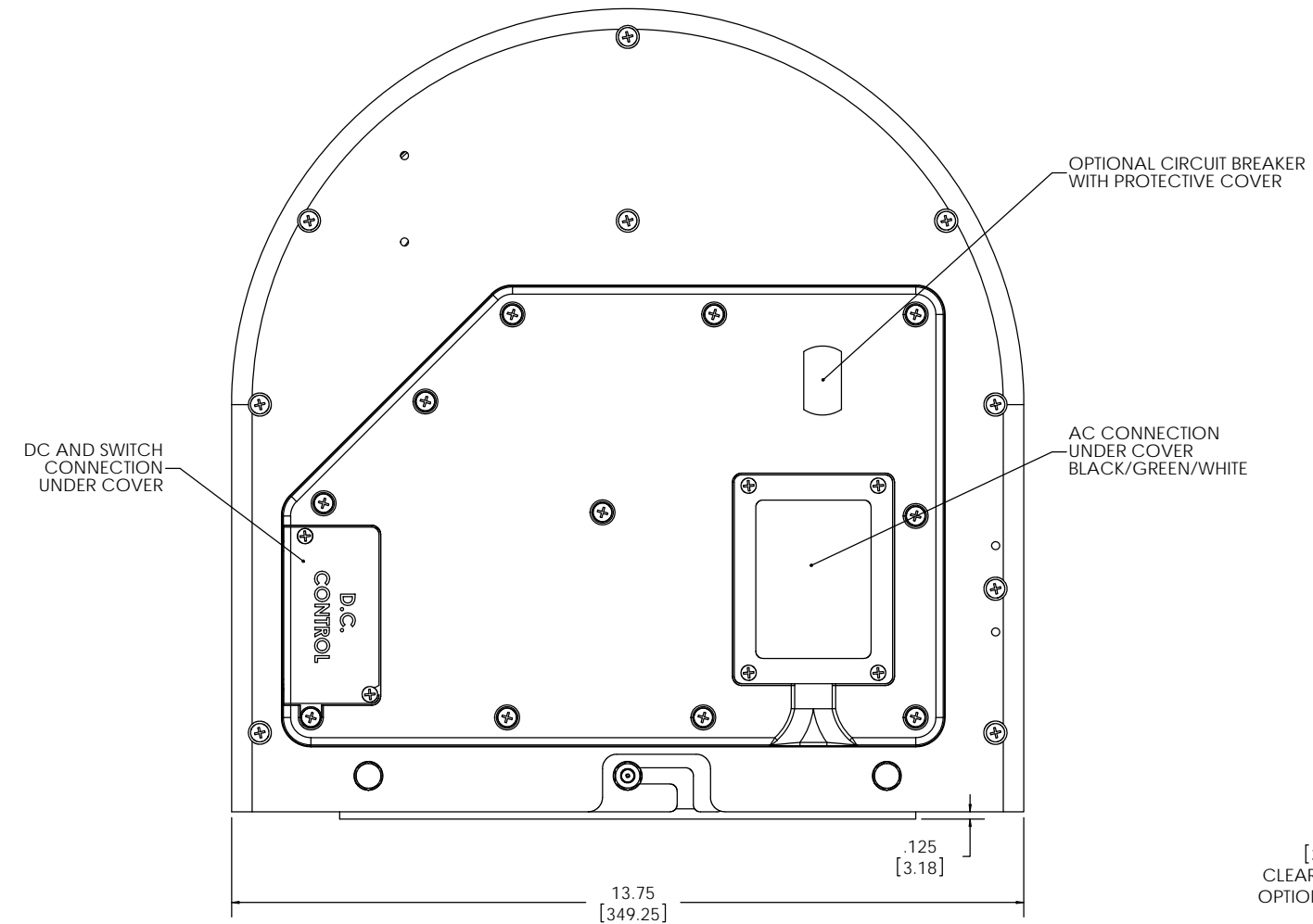
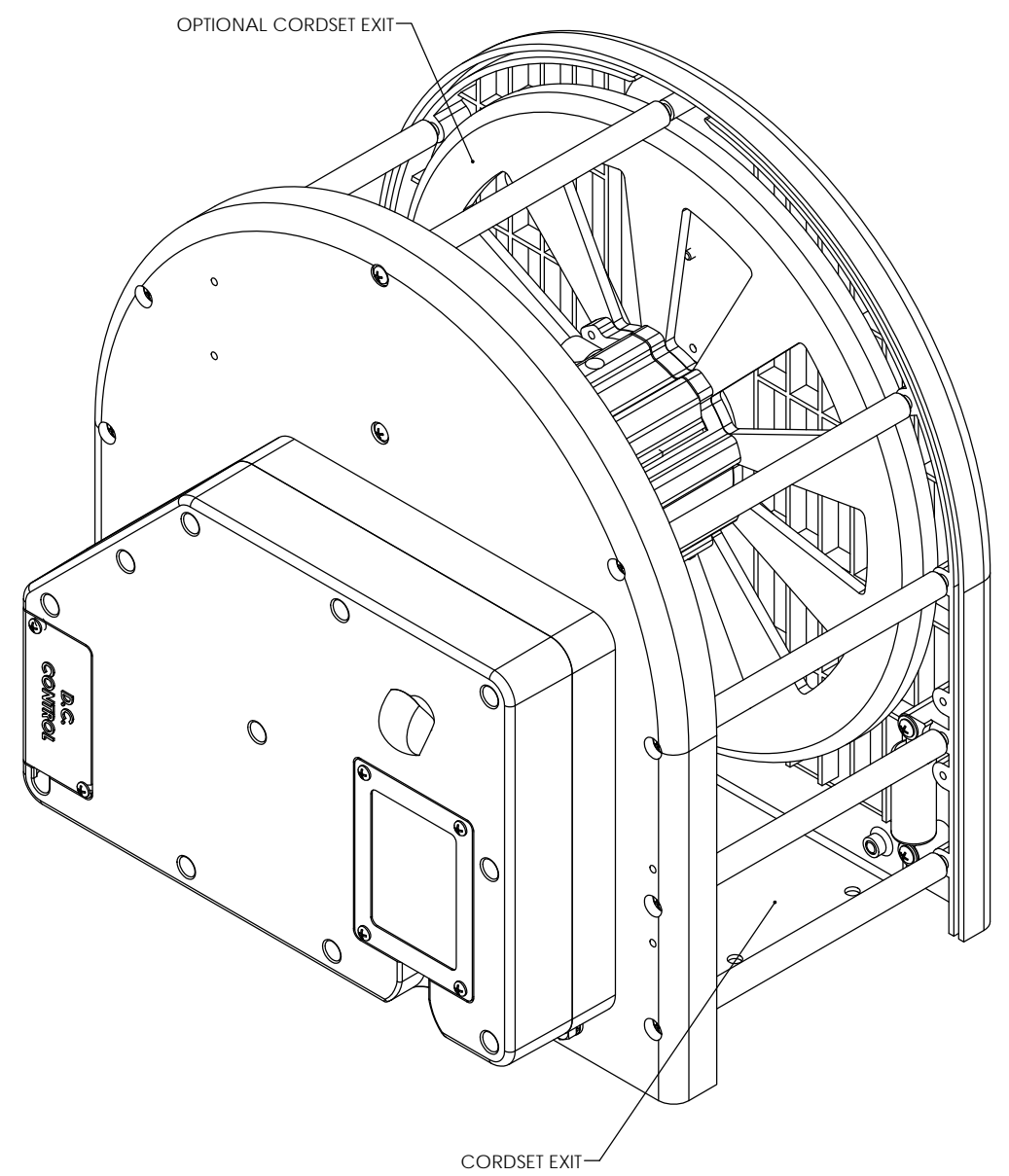
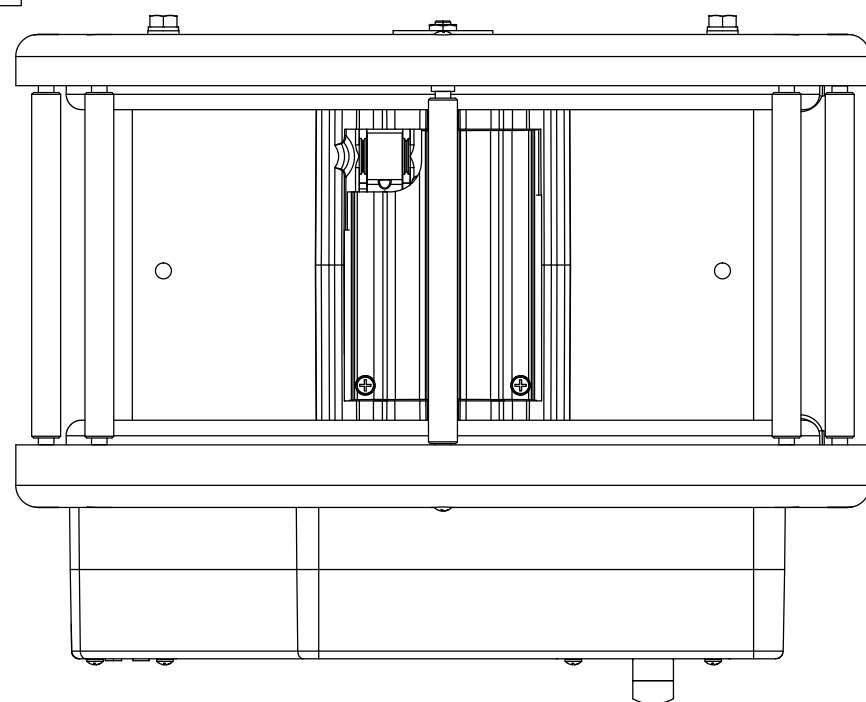

NOTES:
 1) SUPPLIED WITH 50' OF 10/3, 105°C CORD WITH PLUG - WHITE.
 2) APPROXIMATE WEIGHT WITH 50' CORDSET - 32.2 LBS[14.6kg].

GLENDDINNING MARINE PRODUCTS INC.			
740 CENTURY CIRCLE CORNWAY SC 29520			
PH: 843.360.0200 FAX: 843.360.2500			
ASSY- CORD REEL, CRM-30			
DWG NO: 04300			
SIZE	SCALE	REV	A
D	1:2		
DESIGNED BY	DATE		
MMR	7.10.08		